

POWER-LOCK FASTENER

PROFILE CONNECTION WITHOUT MACHINING

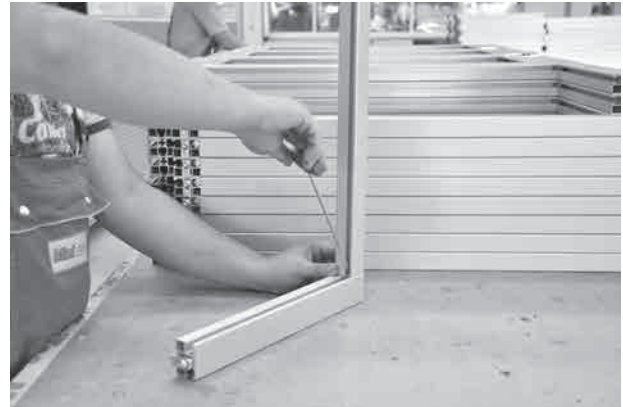

Due to recent studies there is much optimization potential especially in connection technology for profile systems. The connection must be seen as a complete system.

The total cost of a connection is composed of a number of factors:

- Design and dimensioning of bores and threads
- Providing equipment and devices
- Procurement and management of drilling and threading tools
- Work Preparation
- Working time for drilling, threading
- Internal transport

The decisive factor in this consideration is not the cost of the individual connectors. Fundamental cost factor is working time - both in design, production planning and workshop.

MiniTec power-lock fastener 45 SF

Apart from the cost and time advantages, the MiniTec power-lock fastener has numerous other advantages such as subsequent adjustment, ESD suitability, ergonomic design and optical advantages. The MiniTec power-lock fastener has become even faster with the thread-forming screws. The connector is simply screwed to the profile with the screw at the front. With a standard cordless screwdriver this whole process takes a maximum of 3 seconds. No preparation for drilling, threading, measuring or planning is required. Not only the economic superiority speaks for the MiniTec connector with self-tapping screw: Thanks to the trilobular shank shape combined with the radius profile shape of the thread flanks, the new screws develop low torques. The radius profile shape causes low material displacement and reduces the amount of forming work required. The torque moments are up to 50% lower. This ensures reliable assembly and higher clamping forces with less clamping force dispersion.

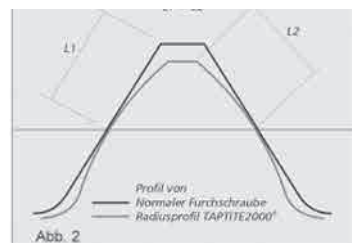
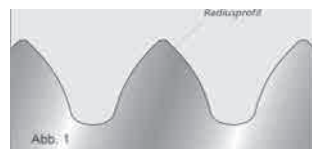

POWER-LOCK FASTENER

PROFILE CONNECTION WITHOUT MACHINING

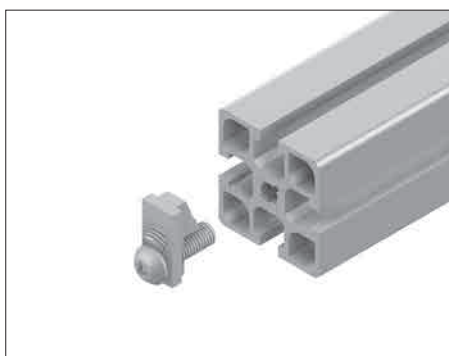

1

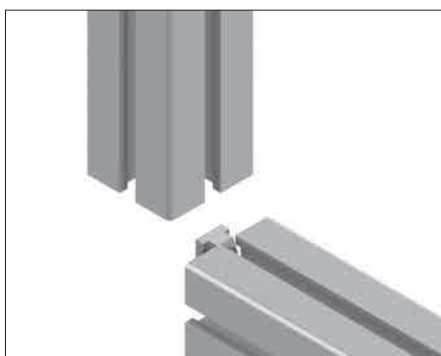

2



3

ASSEMBLY

1. Slightly tighten pressure piece with screw M8 x 25 on the front side of the profile
2. Push profile 2 with its groove beneath the edges of the pressure piece until the desired position is reached
3. Tighten ste screw M8 with hex screwdriver SW4. Recommended tightening torque approximately 12 Nm

Advantages

- The corners of the profile connection remain free for surface elements
- The joint is invisible from the outside
- Secured against rotation
- Load capacity: 6000 N (UL-Profile: 4000N)
- Cross connections can be easily implemented
- For ESD applications, the electrical conductivity of the two profiles must be produced separately for this connector. *
- Ergonomically optimized
- With the "SF" version, no thread needs to be inserted in the profile beforehand. The thread is produced automatically by screwing the screw into the central bore of the profile.

Name	Part no.	Description
Power-Lock fastener 45	21.1018/0	with filister screw M8/SW5
Power-Lock fastener 45 SF	21.0818/0	with self-tapping Torx screw M8/T40,
Power-Lock fastener 45 H	21.1018/1	Cylindrical screw M8/SW5, Corrosion resistant version version for use in corrosive environ- ments
Power-Lock fastener 45 SF short *	21.0020/0	with self-tapping Torx screw M8/T40, for profile connections with flush end cap
Power-Lock fastener30	21.0014/0	with filister screw M8/SW5
Power-Lock fastener 30 SF	21.0016/0	with self-tapping Torx screw M8/T40



Impulse wrench **Part no. 26.0800/0**
for particularly joint-gentle work.

CROSS-CONNECTOR

FRICTIONAL CONNECTION OF INTERSECTING PROFILES WITHOUT MACHINING



Both profiles are adjustable in direction of the groove. Particularly suitable for the attachment of linear axes LR / LB to machine frames.

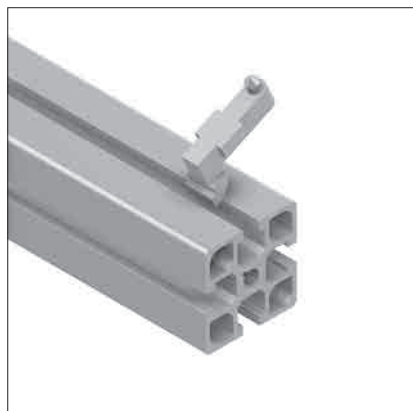

1

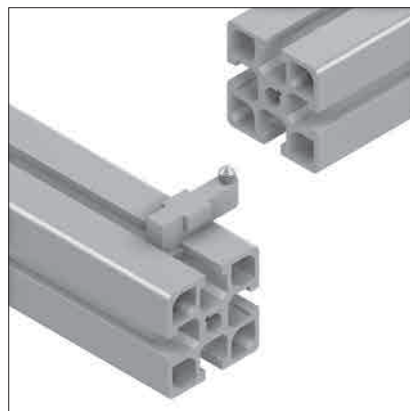

2

ASSEMBLY

1. Swivel the connector into any existing base frame
2. Insert the profile to be connected over the connector
3. Position the brace profile
4. Tighten the set screw in the connector with a torque of 10 Nm

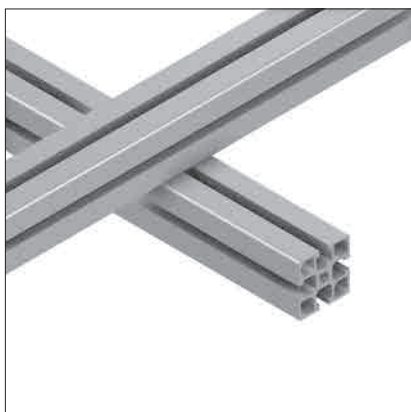

3

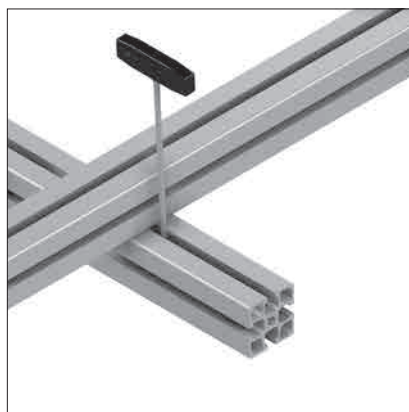

4

POWER-LOCK FASTENER N

FOR SUBSEQUENT FITTING OF PROFILES INTO EXISTING FRAMES WITHOUT MACHINING

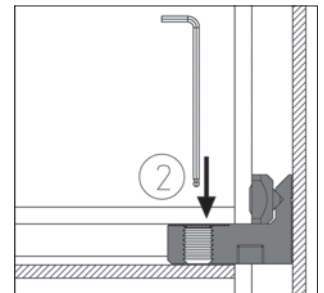
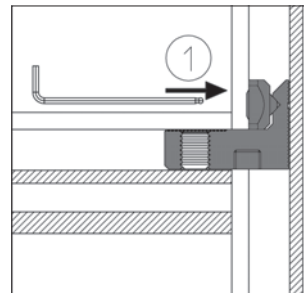
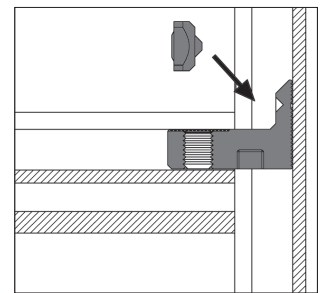
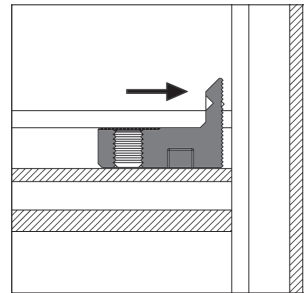
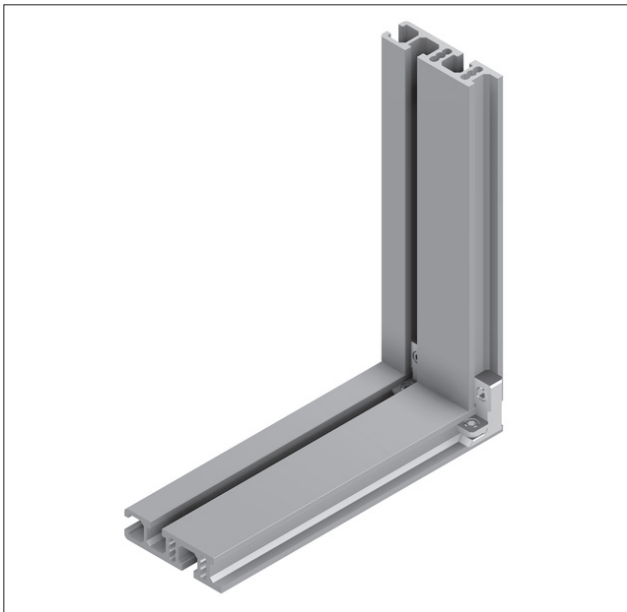

1

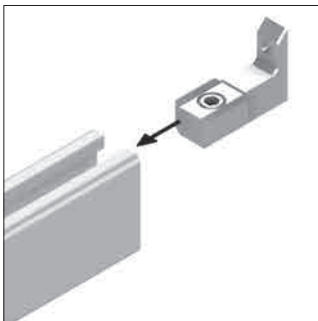

2

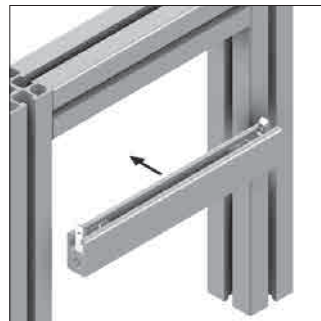

3

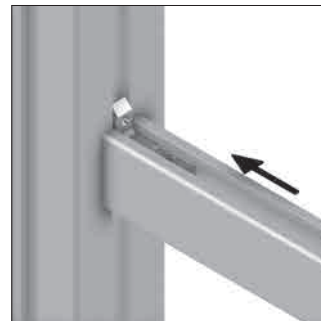

4

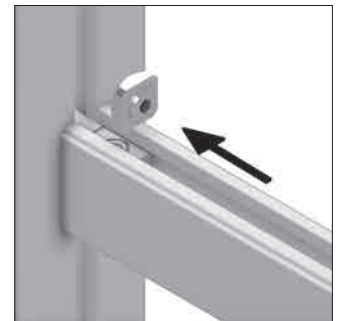

ASSEMBLY

1. Slide the connector into the strut to be retrofitted
2. Position the strut in the construction
3. Slide connector into existing profile
4. Insert square nut with pre-assembled stud into the groove, position via connector and tighten, then tighten screw in connector (both 10 Nm).

MITRE CONNECTIONS

CONSTRUCTIONS WITH HIGH VISUAL DEMANDS

Mitre connections are used for high visual requirements on design. It should be noted that the capacity of these compounds are less than standard connectors. For heavily loaded structures mitre connections should not be used!

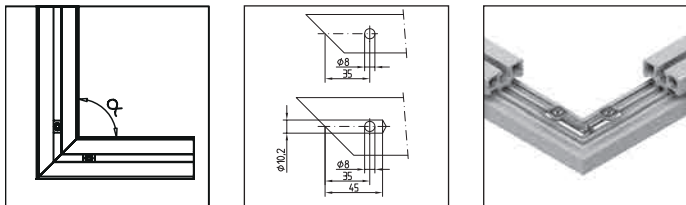

Mitre connector
for front side connection of profiles at any angle of 30° to 180°

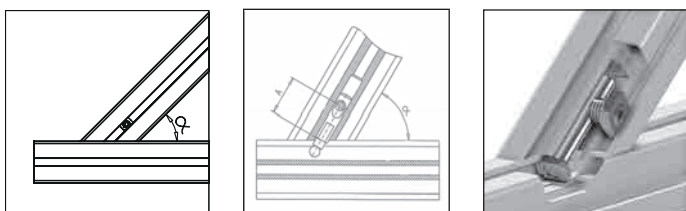

Mitre connector N
for connecting profiles with the grooves of continuous profiles at any angle of 30° to 90°

Description	Part no.	Description
Mitre connector 45 for profiles series 45	21.1400/0	Drill Ø 10.2 mm bore in the profile core bore. Drill Ø 8.2 bore at the distance 36.5 mm from the profile end. Insert the mitre connector in both open profile ends, position the M8 square nut with the set screw and tighten it.
Mitre connector 30 for profile series 30	21.1890/0	Core bore needs no machining. Other installation steps like mitre connector 45.
Mitre connector N 45 for profile series 45	21.1401/0	Drill Ø 10.2 mm bore in the profile core bore. Drill Ø 8.2 bore depending on the angle and at distance A from the profile end /see table). Insert the mitre connector in the open profile end, position the M8 square nut with the set screw and tighten it.
Mitre connector N 30 for profiles series 30	21.0945/0	Core bore needs no machining. Other installation steps like mitre connector N 45.

TIPP

- Drilling jig part no. 26.1050/0 for mitre connector 45
- Drilling jig part no. 26.1060/0 for mitre connector N45
- Drilling jig part no. 26.1063/0 for mitre connector 30
- Drilling jig part no. 26.1056/0 for mitre connector N30

MITRE CONNECTIONS

CONSTRUCTIONS WITH HIGH VISUAL DEMANDS

Drilling jig for mitre connector N30 / N45

Distance A (position of the lateral bore of the threaded pin) depends on the mitre angle. The exact amount is to be taken from the middle bore core drilling of the mitred profile to the middle of the drilling. To safely exclude dimensional errors and ensure the correct functioning of the connection, we recommend the use of our drilling jig for mitre connector N30, part no. 26.1056/0 or N45 part no. 26.1060/0.

Distances for common angles:

α	30°	35°	40°	45°	50°	55°	60°	65°	70°	75°	80°	85°	90°
A(mm)	21,0	22,9	24,8	25,9	27,0	27,6	28,2	28,6	29,0	29,2	29,4	29,45	29,5



Mitre connection N

Drilling jig for mitre connector 30 / 45

Distance A (position of the lateral bore of the threaded pin) for front-side connection of profiles is consistently 35 mm. The exact amount is to be taken from the middle bore core drilling of the mitred profile to the middle of the drilling. To safely exclude dimensional errors and ensure the correct junctioning of the connection, we recommend the use of our drilling jig for mitre connector 30, part no. 26.1063/0 or 45 part no. 26.1050/0.

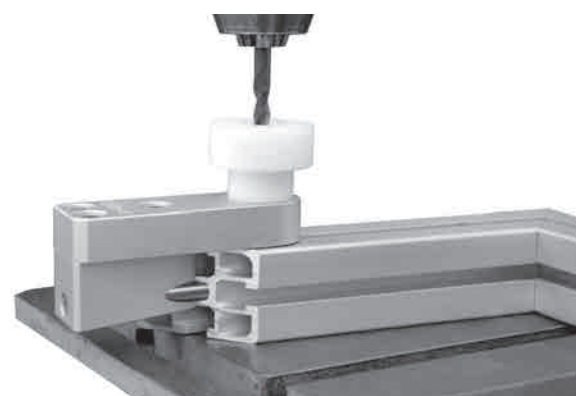

Use of MiniTec drilling jigs

Slide jig central bore of the mitred profile to the stopper. Tighten with screw. Insert into profile with bore through the drilling guide inside the fixing screw.

BOLT AND BUTT CONNECTORS

SUBSEQUENT ASSEMBLY OF PROFILES INTO EXISTING FRAMES, EXTENSION OF PROFILES

Bolt connectors

To compensate for the lower load capacity compared to our standard connectors, bolt connectors should always be used in pairs. The weakening of the profile cross-section must be taken into account.

The correct functioning of this connection requires precise machining of the connecting bore. The distance from the end of the profile of 22.5 mm \pm 0.3 mm must be observed. Another criterion is the precise shape of the connecting bore. Deviations from the circular shape lead to a reduction in the load-bearing surface of the connector. It is therefore necessary to drill the connecting bore on a milling machine.

This connection is not suitable for constructions with air flow in the profile for pneumatic applications.

Butt connectors

The machining of the profiles corresponds to the machining of the connectors. For the profile extension we recommend the combination of steel butt connectors and clamping strips.

T-slot bar 90

- Profile extension
- Slide into profile groove and clamp with set screws
- No machining required
- For larger profile cross-sections or higher loads, please use several t-slot bars.
- Can be used in combination with butt connectors

Application

For rectangular connection of profiles

- Subsequent mounting of profiles into existing frames
- Adjustable
- Extension of profiles

Processing

Step drilling $\varnothing 7 / \varnothing 20$ mm, resp. $\varnothing 9 / \varnothing 15$ mm, 16 mm depth: middle of the groove, 20 mm from profile end. Use drilling jig for positioning.

1. Insert hex screw M8 x 35 in bolt and - if possible - preassemble square nut into second profil.
 2. Insert bolt in step drilling and connect with square nut.
 3. Pretighten with ball-headed key SW5. Final tightening with L-key 5 A/F.
- Recommended locking torque: 15 Nm
 - Static load: 3500 N

Mounting bracket 45

- Profile extension
- Connection of profiles
- Subsequent insertion of profiles into existing constructions
- Removable attachments
- Movable in groove direction

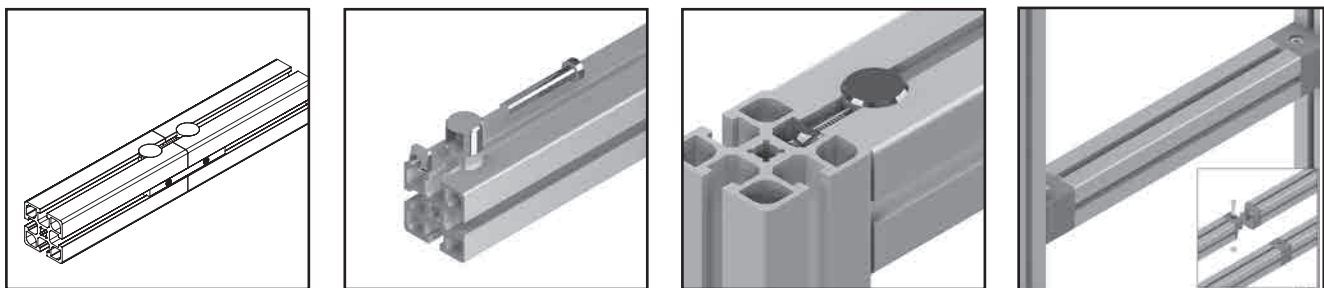

Description	Part no.	Description
Bolt connector 15	21.1024/0	For profile series 32 and narrow side 19 9x15 stepped bore, 16 mm tief, 22,5 mm from the end of profile
Bolt connector 20	21.1021/0	For profile series 45 7x20 stepped bore, 16 mm deep, 22,5 mm from the end of profile
Butt connector 20	21.1020/0	For profile series 45 7x20 stepped bore, 16 mm deep, 22,5 mm from both ends of profile
T-slot bar 90	21.1029/0	For profiles with grid dimension 45 Slide into groove and fasten
Mounting bracket 45	21.1411/0	For profiles with grid dimension 45 Insert face front thread



Drilling jig part no. **26.1092/0** for correct position of the stepped bore

SCREW CONNECTION

FORM-LOCKING CONNECTION WHICH MUST BE SECURED AGAINST DISLOCATION



APPLICATION

- Construction with high dynamic loads

Processing

Thread M8; step drilling $\varnothing 9 / \varnothing 15$ mm with drilling jig M8 x 50;

- Position anti-twist lock in the groove
- Push the screw through anti-twist lock
- Screw in and tighten the screw into threaded connection profile
- Recommended locking torque: 20 Nm
- Static load: 18 000 N

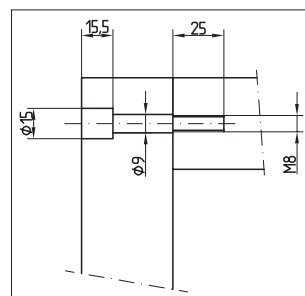
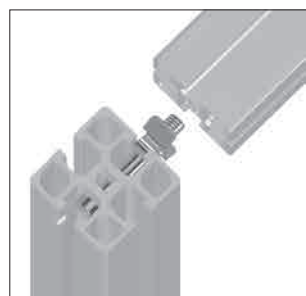
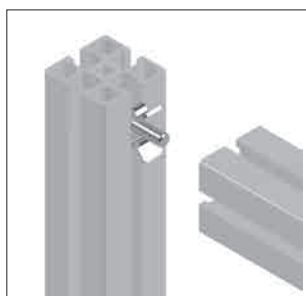
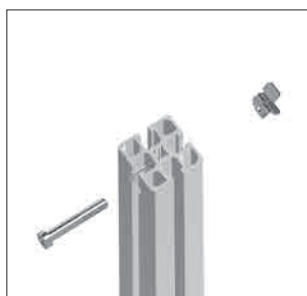

Stepped bore



Drilling jig part no. **26.1092/0** for correct position of the stepped bore

MOUNTING ANGLES

EASY INSTALLATION WITHOUT PROCESSING

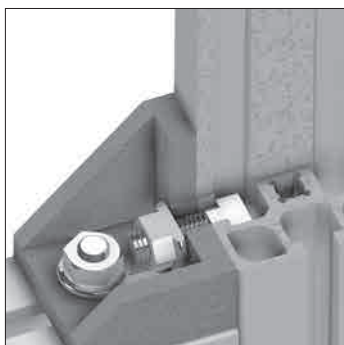

Angle aluminum die casting, powder coated, grey

- No processing
- Retrofitting of profiles possible
- Adjustable



Optional with cover

Caps made of oil resistant ABS, grey

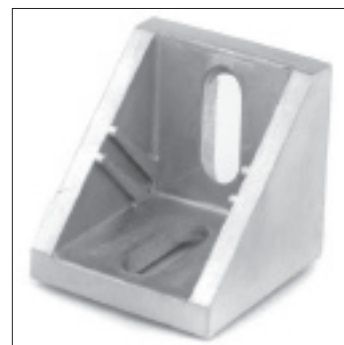

ESD version

- Without powder coating
- With ESD square nuts Z

ASSEMBLY

- Use fastening material from fastening kit.

LOAD CAPACITY

angle	Number of screws	Fmax (N)	Mmax (Nm)
Mounting angles 19	2	3.600	280
Mounting angle 25	2	3.600	280
Mounting angles 45	2	3.600	280
Mounting angles 45x90	4	7.200	560
Mounting angles 90	8	14.400	1.120

All values include double safety

These values are valid only for angles mounted in pairs if used one-sided, the load reduces as follows:

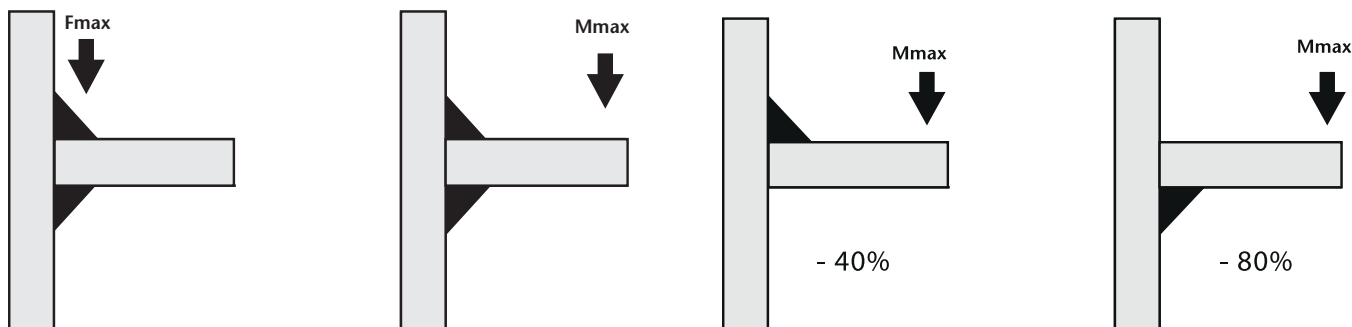

PROTECTIVE FIELD SUSPENSION, ADJUSTABLE ANGLE (part no. 21.1403/0)

CONNECTING PROTECTION FIELDS

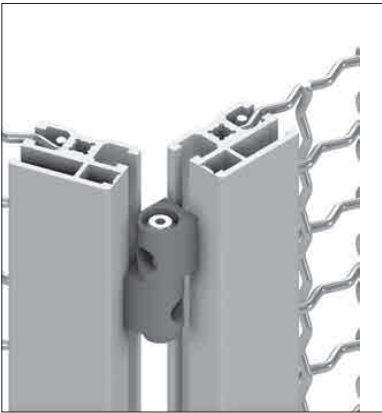

MOUNTING POSSIBILITIES

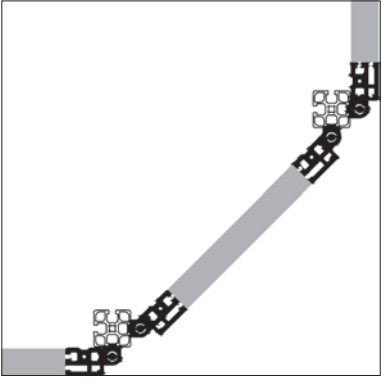
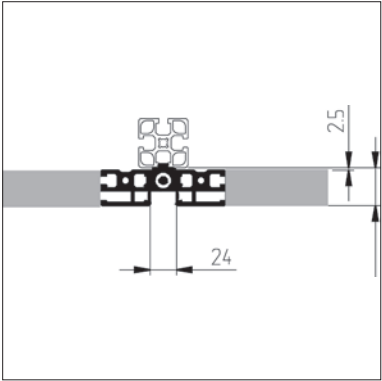
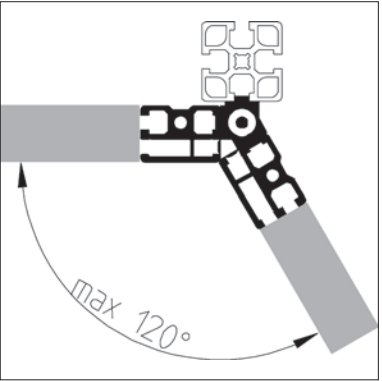
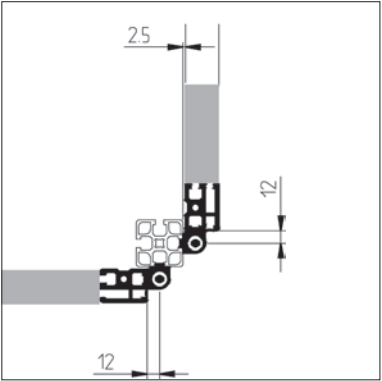

SCREWS

OTHER STANDARDS AND DIMENSIONS ARE AVAILABLE ON REQUEST

CYLINDER SCREWS

M8 with flat head and hexagon socket



Thread	Galvanized	Stainless
M08 x 12	21.1264/0	
M08 x 16	21.1200/0	21.1200/1
M08 x 18	21.1268/0	
M08 x 20	21.1202/0	21.1202/2
M08 x 22	21.1280/0	21.2017/0
M08 x 25	21.1204/0	21.1204/1
M08 x 30	21.1206/0	21.1206/1
M08 x 35	21.1208/0	21.1208/1
M08 x 40	21.1210/0	21.1210/1
M08 x 45	21.1211/0	
M08 x 50	21.1212/0	21.1212/1
M08 x 55	21.1877/0	
M08 x 60	21.1214/0	
M08 x 65	21.1299/0	
M08 x 70	21.1282/0	
M08 x 75	21.1392/0	
M08 x 80	21.1225/0	
M08 x 90	21.1226/0	
M08 x 100	21.1662/0	

M6 with flat head and hexagon socket

Thread	Galvanized	Stainless
M06 x 12	21.1143/0	21.1143/1
M06 x 14	21.1367/0	
M06 x 16	21.1238/0	21.1238/1
M06 x 18	21.1239/0	
M06 x 20	21.1240/0	21.1340/1
M06 x 22	21.1265/0	
M06 x 25	21.1242/0	21.1242/1
M06 x 30	21.1243/0	21.1243/1
M06 x 35	21.1245/0	21.1693/0
M06 x 40	21.1247/0	21.1247/1
M06 x 45	21.1172/0	
M06 x 50	21.1171/0	21.1171/1
M06 x 55	21.1248/0	21.1248/1
M06 x 60	21.1154/0	
M06 x 65	21.1868/0	
M06 x 70	21.1591/0	

M5 with flat head and hexagon socket

Thread	Galvanized	Stainless
M05 x 08	21.1193/0	
M05 x 10	21.1279/0	
M05 x 12	21.1220/0	21.1220/1
M05 x 16	21.1235/0	
M05 x 20	21.1222/0	
M05 x 25	21.1224/0	21.1224/1
M05 x 30	21.1237/0	21.1237/1
M05 x 35	21.2195/0	
M05 x 40	21.1284/0	21.1284/1
M05 x 45	21.1219/0	
M05 x 50	21.1691/0	
M05 x 55	21.1353/0	

COUNTERSUNK SCREWS

M8 with hexagon socket



Thread	Galvanized	Stainless
M08 x 10	21.1552/0	21.1550/0
M08 x 12	21.1263/0	
M08 x 16	21.1513/0	21.1513/1
M08 x 20	21.1514/0	21.1514/1
M08 x 25	21.1520/0	
M08 x 30	21.1516/0	
M08 x 35	21.1947/0	
M08 x 40	21.1547/0	
M08 x 45	21.1645/0	
M08 x 50	21.1517/0	21.1517/1
M08 x 55	21.1546/0	
M08 x 60	21.1523/0	
M08 x 65	21.1949/0	
M08 x 70	21.1950/0	
M08 x 90	21.1946/0	

M6 with hexagon socket

Thread	Galvanized	Stainless
M06 x 10	21.2219/0	21.2219/1
M06 x 12	21.1518/0	
M06 x 16	21.1506/0	21.1506/1
M06 x 20	21.1507/0	
M06 x 25	21.1566/0	
M06 x 30	21.1508/0	
M06 x 35	21.1509/0	
M06 x 40	21.1510/0	
M06 x 45	21.1951/0	
M06 x 50		21.2236/1
M06 x 55	21.1511/0	
M06 x 60	21.1512/0	
M06 x 65	21.2156/0	
M06 x 70	21.2134/0	

M5 with hexagon socket

Thread	Galvanized	Stainless
M05 x 10	21.1532/0	
M05 x 12	21.1543/0	21.1595/0
M05 x 14	21.1519/0	
M05 x 16	21.1503/0	21.1503/1
M05 x 18	21.1537/0	
M05 x 20	21.1504/0	
M05 x 25	21.1505/0	
M05 x 30	21.1482/0	
M05 x 35	21.2215/0	
M05 x 40	21.2127/0	
M05 x 45	21.1945/0	21.1945/1
M05 x 50	21.2123/0	

M4 with hexagon socket

Thread	Galvanized	Stainless
M04 x 08	21.1500/0	
M04 x 10	21.1557/0	
M04 x 12	21.1948/0	
M04 x 16	21.1501/0	21.1501/1
M04 x 20	21.1502/0	
M04 x 25	21.1571/0	
M04 x 30	21.1203/0	

SQUARE NUTS, RHOMBUS NUTS AND SQUARE WASHERS

AVAILABLE FOR M3, M4, M5, M6 AND M8



Square nuts 30 with position-fixing, ESD-conductive

Description	Galvanized	Stainless
M8	21.1570/0	-
M6	21.1569/0	-
M5	21.1568/0	-
M4	21.1567/0	-

Square nuts



Description	Galvanized	Stainless
M8	21.1351/0	21.1351/1
M6	21.1330/0	21.1330/1
M5	21.1320/0	21.1320/1
M4	21.1310/0	21.1310/1
M3	21.1309/0	21.1309/1

Square nuts with position-fixing



Description	Galvanized	Stainless
M8	21.1351/2	21.1351/4
M6	21.1330/2	21.1330/4
M5	21.1320/2	21.1320/4
M4	21.1310/2	21.1310/4
M3	21.1309/2	21.1309/4

Square nuts Z, ESD conductive



Description	Galvanized	Stainless
M8	21.1390/0	-
M6	21.1391/0	-
M5	21.1627/0	-

Square nuts Z with position-fixing, ESD conductive



Description	Galvanized	Stainless
M8	21.1390/2	-
M6	21.1391/2	-
M5	21.1627/2	-

SPECIAL SCREWS

Screws for power-lock fastener



Fillister head screw	Galvanized	Stainless
M08 x 25	21.1189/0	-
M08 x 25 SF*	21.1492/0	-

*self-tapping thread

Screws for end caps VA/AL/LR



Flat head screw	Galvanized	Stainless
M08 x 10	-	21.1666/0

Square nuts can be pivoted at any point in the profile. When used in the vertical profile apply square nut with position-fixing. Can be pivoted like the standard square nut; the position-fixing holds the nut in the desired position.

Square nut Z must be used for ESD applications.

Available from M5 to M8, with and without spring plate.

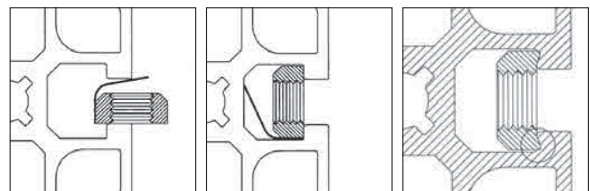

with position-fixing

ESD conductive

Square nuts M8 L



Description	Galvanized	Stainless
M8	21.1368/0	-

Square nuts M8 L with position-fixing



Description	Galvanized	Stainless
M8	21.1368/2	-

Rhombus nut F

(Thread M6 with pitch error for self-locking of the screw connection)



Description	Galvanized	Stainless
M6	21.1354/0	-

Square washers



Description	Galvanized	Stainless
Square washers 8	21.1360/0	21.1360/1
Square washers 6	21.1363/0	-
Square washers 5	21.1362/0	-

Hex nut with flange, self-locking



Description	Galvanized	Stainless
M8	21.1334/0	-

Screws for mounting surface elements



Flat head screw	Galvanized	Stainless
M06 x 12	21.2074/0	-
M06 x 16	21.1246/0	-
M06 x 20	21.1246/1	-

POWER-LOCK FASTENER 30 SF

Part no. 21.0016/0

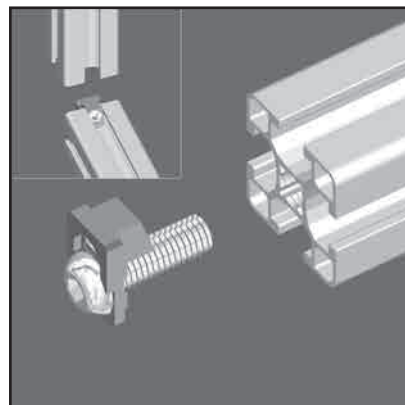
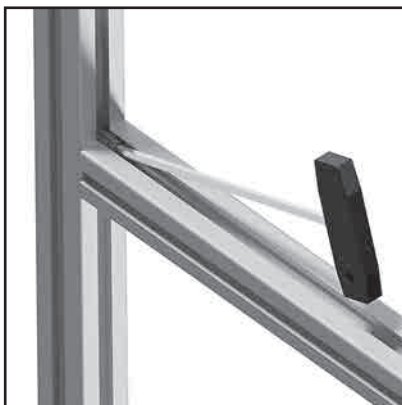
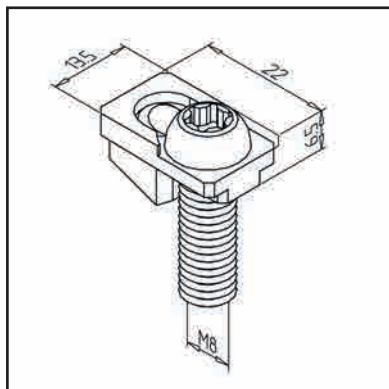

TECHN. DATA / ITEMS SUPPLIED

APPLICATIONS

ASSEMBLY

- Steel, galvanized
- Self tapping torx screw T40
- Power-Lock fastener 30 (standard) **part no. 21.1014/0** with filister head screw A/F 5
- Package size of 100 pieces in Kantainer version SF **part no. 21.0016/0100** version Standard **part no. 21.0014/0100**
- Weight = 0.021 kg/piece

- For force-locked connection
- Also suitable for cross joints
- Appropriate for ESD implementations

- Fasten the connector frontally to the profile with the torx wrench T 40
- Tighten the set screw M8 with the wrench SW 4
- Recommended locking torque: 12 Nm
- For screwing in self-tapping screws for MiniTec power-lock fastener: Impulse wrench **part No. 26.0800/0**

POWER-LOCK FASTENER 45 SF

Part no. 21.0818/0

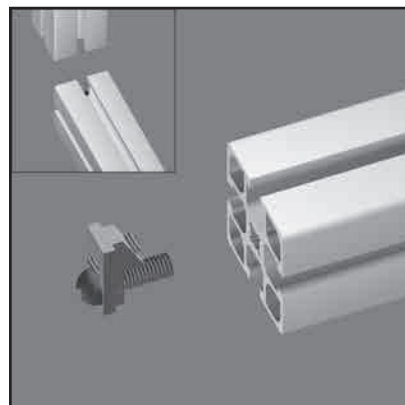
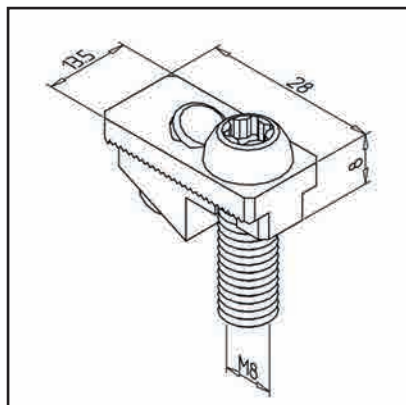

TECHN. DATA / ITEMS SUPPLIED

APPLICATIONS

ASSEMBLY

- Steel, galvanized
- Self tapping torx screw T40
- Power-lock fastener 45 (standard) **part no. 21.1018/0**, with filister head screw SW 5
- Power-Lock fastener 45 H - stainless version **part no. 21.1018/1** with cylinder head screw A/F 5
- Package size of 100 pieces in Kantainer version SF **part no. 21.0818/0100** version Standard **part no. 21.1018/0100**
- Weight = 0.030 kg/piece

- Power-lock connection for all profiles, also suitable for crossjoints
- For larger profile sections several fasteners can be used
- Appropriate for ESD implementations

- Fasten the connector frontally to the profile with the torx wrench T 40
- Tighten the set screw M8 with the wrench SW 4
- Recommended locking torque: 12 Nm
- For screwing in self-tapping screws for MiniTec power-lock fastener: Impulse wrench **part No. 26.0800/0**

POWER-LOCK FASTENER 45 SF SHORT

Part no.

21.0020/0

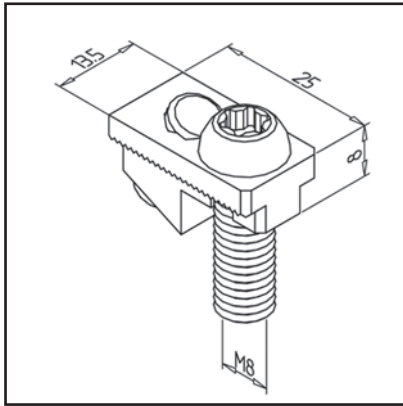
**TECHN. DATA / ITEMS SUPPLIED**

- Steel, galvanized
- Self tapping torx screw T40
- Weight = 0.028 kg/piece

**APPLICATIONS**

- For mounting profiles with flush cover cap
- For ESD applications of the fastener electr. conductivity of the two profiles has to be produced.

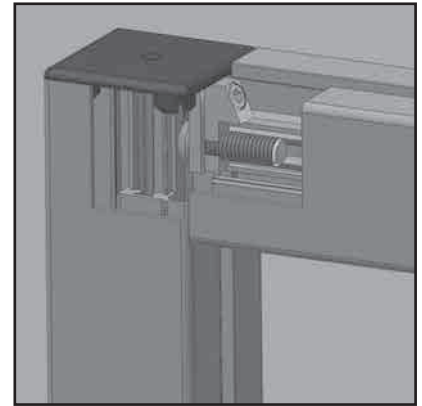
**ASSEMBLY**

- Fasten the connector frontally to the profile with the torx wrench T 40
- Tighten the set screw M8 with the wrench SW 4
- Recommended locking torque: 12 Nm
- For screwing in self-tapping screws for MiniTec power-lock fastener: Impulse wrench **part No. 26.0800/0**

POWER-LOCK FASTENER N 30

Part no.

21.0033/0

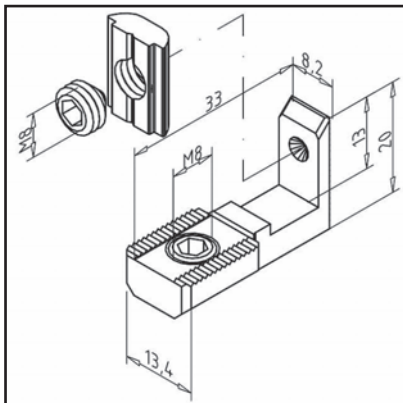
**TECHN. DATA / ITEMS SUPPLIED**

- Steel, galvanized
- Connection element with pre-assembled threaded pin M8
- 1 Slide nut M8 with pre-assembled setscrew
- Weight = 0.025 kg/piece

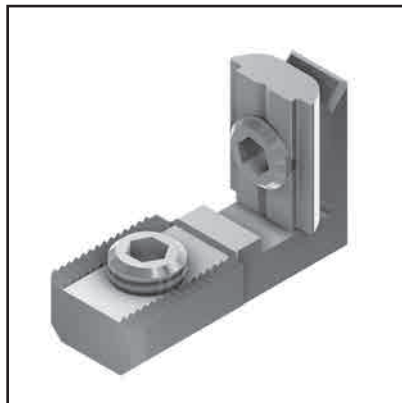
**APPLICATIONS**

- For force-locked connection
- Especially for post-mounting of additional profiles in existing constructions

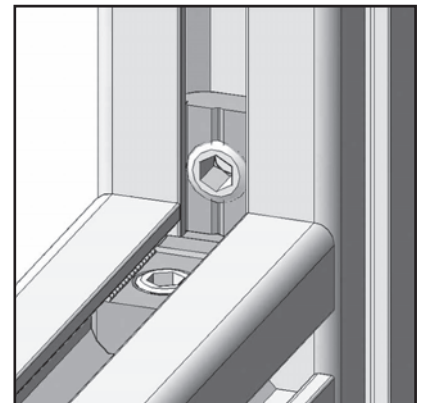
**ASSEMBLY**

- Position the profile with the connector
- Swing in and tighten sliding nut with threaded pin
- Tighten set screw of fastener
- Tighten both threaded pins with SW 4 and with 10 Nm torque

POWER-LOCK FASTENER N 45

Part no.

21.0918/0

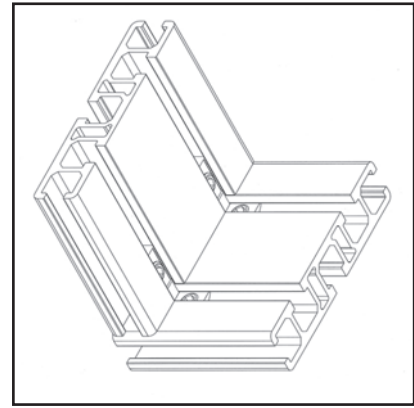
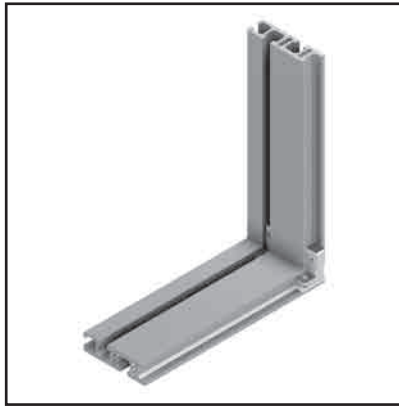
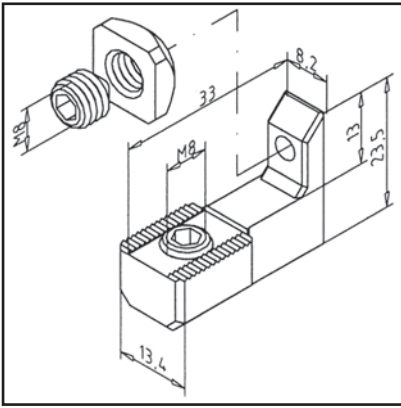

TECHN. DATA / ITEMS SUPPLIED

- Steel, galvanized
- Connection element with pre-assembled threaded pin M8
- 1 Slide nut M8 with pre-assembled setscrew
- Weight = 0.036 kg/piece

APPLICATIONS

- For connecting all profiles of the profile series 45
- Especially for post-mounting of additional profiles in existing constructions
- For profile sections bigger than 45 x 45 several fasteners can be used

ASSEMBLY

- Position the profile with the connector
- Swing in and tighten sliding nut with threaded pin
- Tighten set screw of fastener
- Tighten both threaded pins with SW 4 and with 10 Nm torque

CROSS-CONNECTOR 45

Part no.

21.0006/0

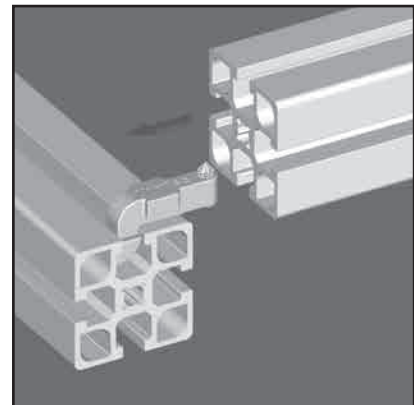
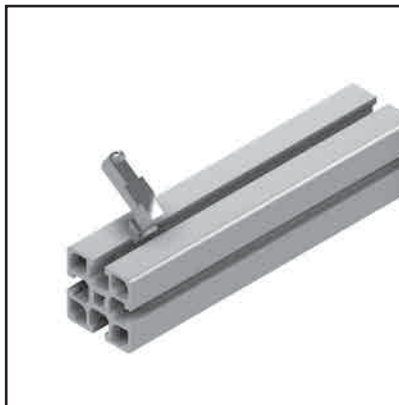
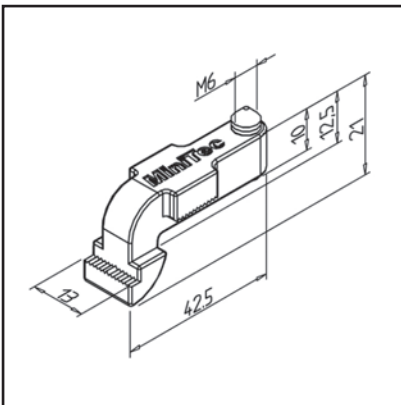

TECHN. DATA / ITEMS SUPPLIED

- Steel, galvanized
- Connection element with pre-assembled threaded pin M6
- Weight = 0.035 kg/piece

APPLICATIONS

- For connecting all profiles of the profile series 45
- Especially for retrofitting profiles into existing constructions
- Suitable for ESD applications

ASSEMBLY

- Swing the connector into the existing frame
- Push the new profile over the connector
- Tighten set screw in connector with wrench size 3 to 10 Nm torque

SCREW-CONNECTION 30 N

Part no.

21.1385/0

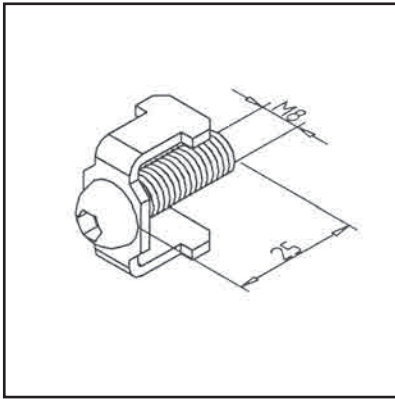

TECHN. DATA / ITEMS SUPPLIED

- Steel, galvanized
- Anti-twist lock with cylinder-head screw
- Weight = 0.017 kg/piece

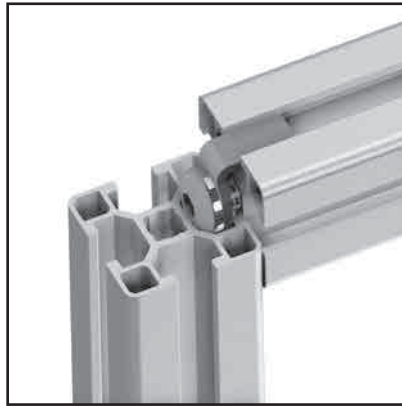

APPLICATIONS

- Connection of profiles

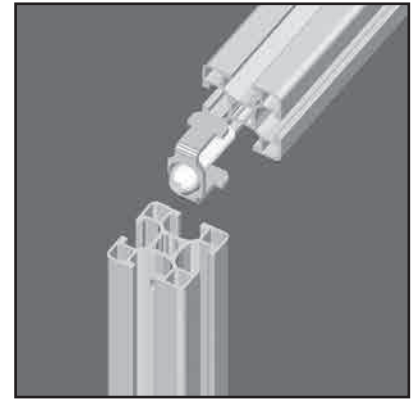

ASSEMBLY

- Bring in the Thread M8 x 25 in the centre borehole of the profile
- Insert bore \varnothing 7 mm in profile 2
- Install screw and anti-rotation lock on profile 1 and insert in groove of profile 2
- Pull through hole \varnothing 7 mm with Allen wrench
- Recommended locking torque: 20 Nm
- The bore \varnothing 7 mm can be closed with plug 7 **part no. 22.1215/1**, should be used with our closed t-slot profiles

SCREW CONNECTION 45

Part no.

21.1017/0

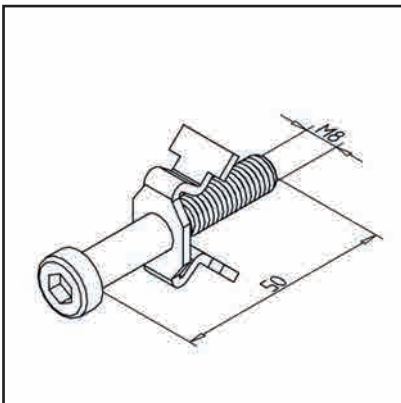

TECHN. DATA / ITEMS SUPPLIED

- Steel, galvanized
- Anti-twist lock with cylinder-head screw
- Weight = 0.027 kg/piece



APPLICATIONS

- Effective against slipping
- Secured connection of all profiles

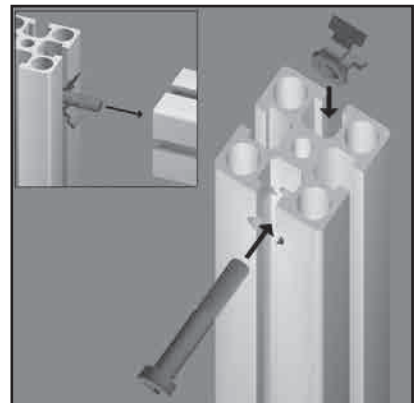

ASSEMBLY

- Insert the threaded screw M8 x 25 into the central bore of profile
- Insert the stepped bore \varnothing 9 x 15 into profile 2
- Insert the anti-twist lock
- Insert the screw through the anti-rotation lock into the tapped hole in profile 2, tighten
- Recommended locking torque: 20 Nm

SCREW CONNECTION 32

Part no. 21.1386/0

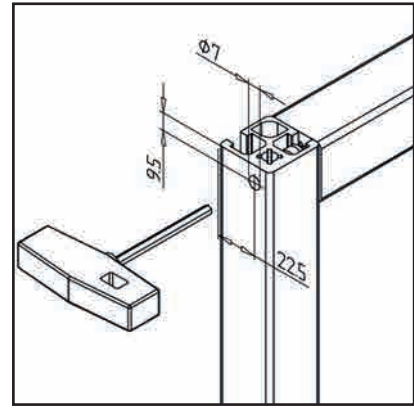
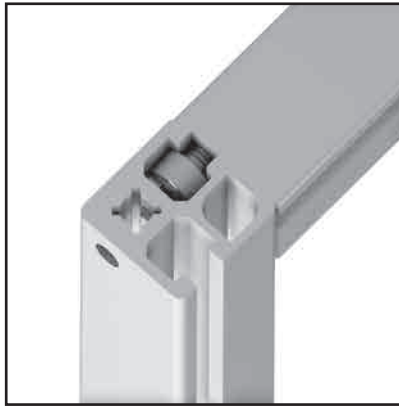
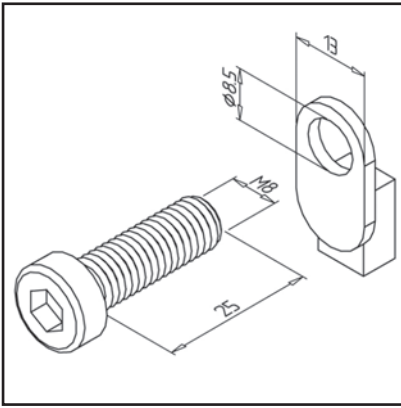

TECHN. DATA / ITEMS SUPPLIED

- Aluminium, Pressure die-casting
- Hex socket cap screw M8 x 25
- Weight = 0.015 kg/piece

APPLICATIONS

- Effective non-rotating connection for 32mm and 19mm profiles

ASSEMBLY

- Insert the threaded screw M8 x 25 into the central bore of profile
- Insert bore \varnothing 7 mm in profile 2
- Fasten the screw to the profile 1 with the anti-twist lock and insert it into profile 2
- Tighten the screw to 20 Nm
- The bore \varnothing 7 mm can be closed with plug 7 **part no. 22.1215/1**, should be used with our closed t-slot profiles

HAMMER SCREW

Part no. 21.1370/0

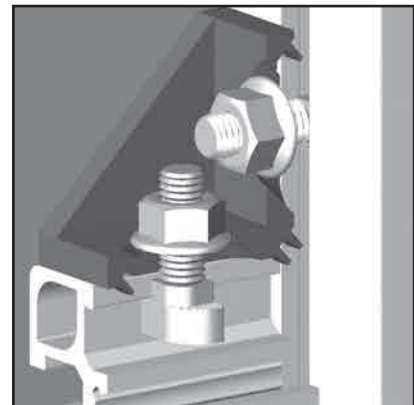
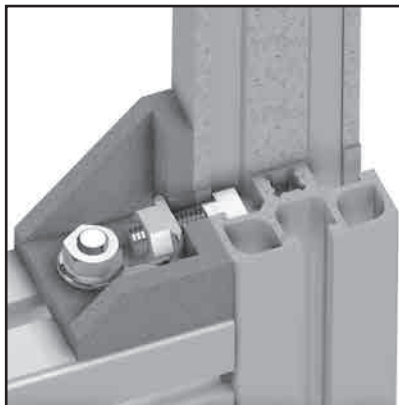
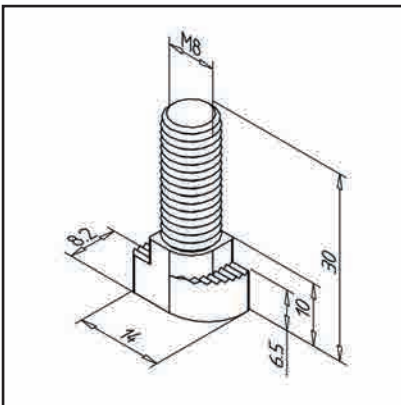

TECHN. DATA / ITEMS SUPPLIED

- Steel, galvanized
- Thread (d) : M 8
- Length (l) : 23.5 mm
- Weight = 0.013 kg/piece

APPLICATIONS

- Simple attachment of add-on parts or accessories on profiles
- Attachment of mounting bracket: 45 x 90 GD-Z **part no. 21.1397/0**, 45 GD **part no. 21.1133/0**, 45 GD-Z **part no. 21.1349/0**, 90 GD-Z **partno. 21.0978/0**

ASSEMBLY

- Insert the hammer screw in the profile groove, screw on nut M8
- When tightening the nut, the hammer head will turn crosswise
- **Recommended nut:** Hexagon nut self-locking with flange **part no. 21.1334/0**

BOLT CONNECTOR 15

Part no.

21.1024/0

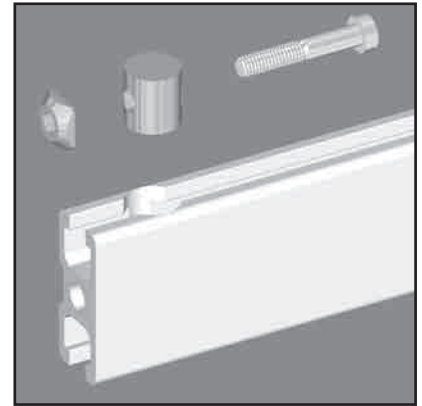
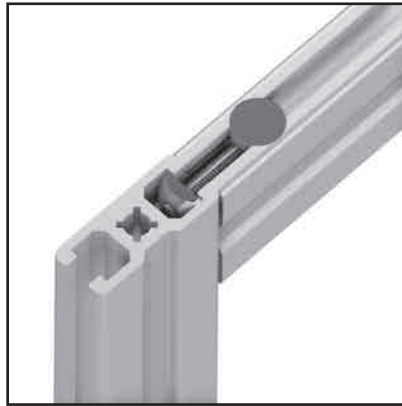
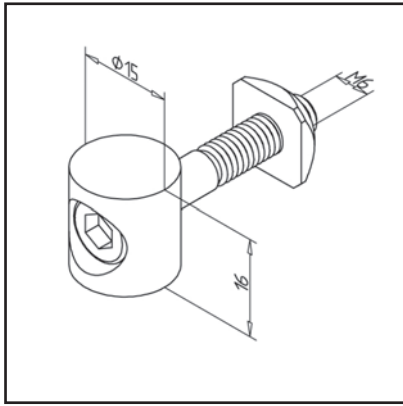
**TECHN. DATA / ITEMS SUPPLIED**

- Aluminium, anodized E6/EV1
- With fastening material steel, zinc plated
- Weight = 0.032 kg/piece

APPLICATIONS

- Connection of profiles 19 and 32
- Especially for post-mounting of additional profiles in existing constructions

ASSEMBLY

- Insert the stepped bore $\varnothing 9 \times 15$, 16 mm deep, positioned 22.5 mm from the end of the profile to the center of the groove
- Insert the connector and pre-tighten the screw with the ball head wrench SW 4
- Fastening with Allen wrench
- Recommended locking torque: 15 Nm

BOLT CONNECTOR 20

Part no.

21.1021/0

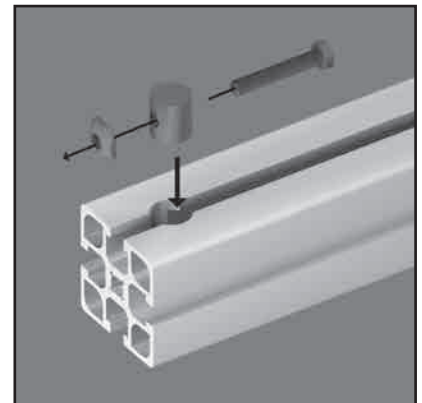
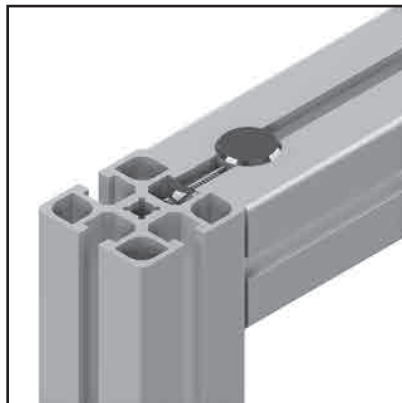
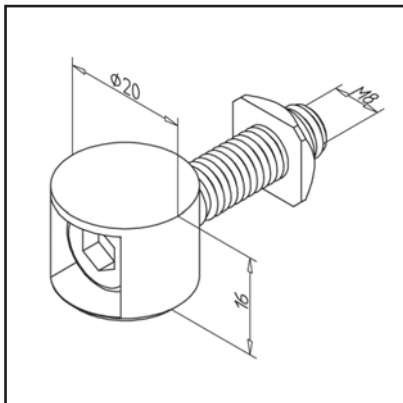
**TECHN. DATA / ITEMS SUPPLIED**

- Zinc, Pressure die-casting, galvanized
- With fastening material steel, zinc plated
- Weight = 0.036 kg/piece

APPLICATIONS

- For connecting all profiles of the profile series 45
- Especially for post-mounting of additional profiles in existing constructions
- For connection of profile 45 x 19

ASSEMBLY

- Insert the stepped bore $\varnothing 7 \times 20$, 16 mm deep, positioned 22.5 mm from the end of the profile to the center of the groove
- Insert the connector and pre-tighten the screw with the ball head wrench SW 5
- Fastening with Allen wrench
- Recommended locking torque: 15 Nm

BUTT CONNECTOR 20

Part no.

21.1020/0

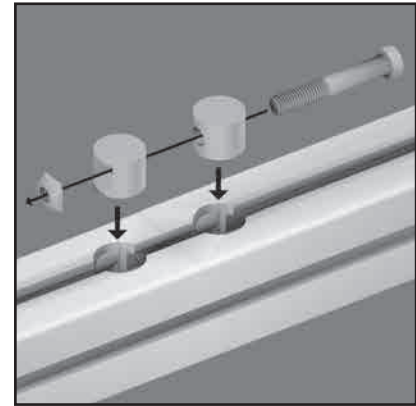
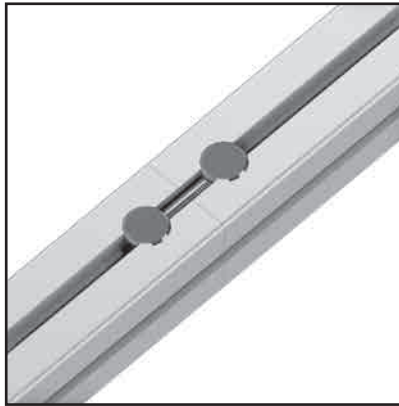
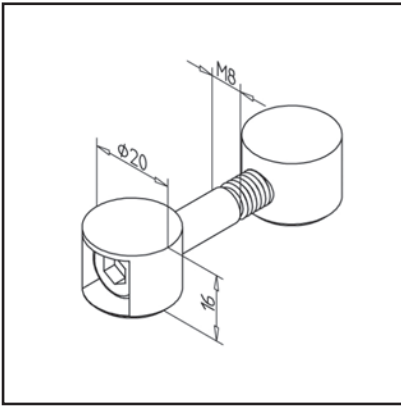

TECHN. DATA / ITEMS SUPPLIED

- Zinc, Pressure die-casting, galvanized
- With fastening material steel, zinc plated
- Weight = 0.056 kg/piece

APPLICATIONS

- Profile extension
- Butt connectors

ASSEMBLY

- Insert the stepped bore $\varnothing 7 \times 20$, 16 mm deep, positioned 22.5 mm from the end of the profile to the center of the groove
- Insert the connector and pre-tighten the screw with the ball head wrench SW 5
- Fastening with Allen wrench
- Recommended locking torque: 15 Nm

T-SLOT BAR 90

Part no.

21.1029/0

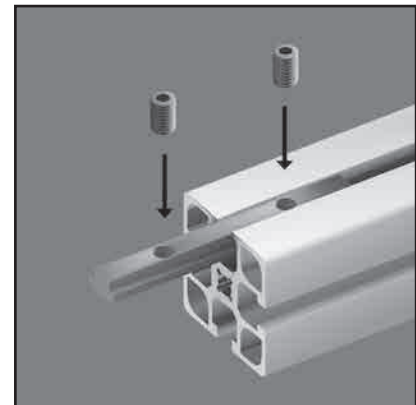
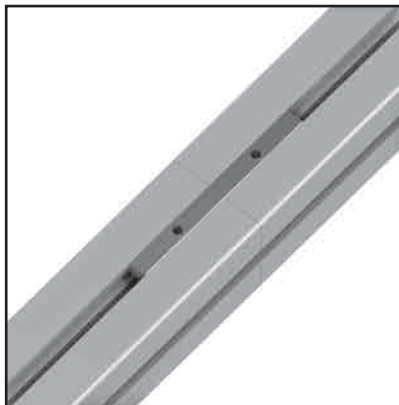
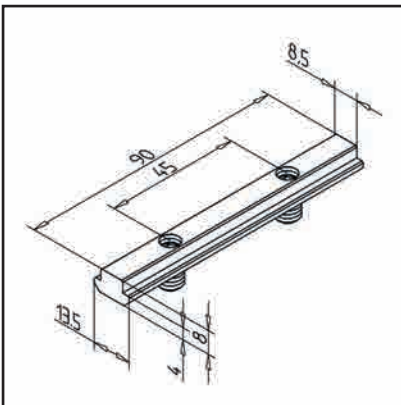

TECHN. DATA / ITEMS SUPPLIED

- Steel, galvanized
- 2 set screws M8, with hexagonal socket SW 4
- Stainless version **part no. 21.0992/0**
- Weight = 0.062 kg/piece

APPLICATIONS

- Profile extension
- Fastening rollers in standard carriages LW

ASSEMBLY

- Swing into profile groove
- Clamp with set screw
- No machining required
- For larger profile cross sections or higher loads, several clamping strips must be used

T-SLOT BAR 135

Part no.

21.0988/0

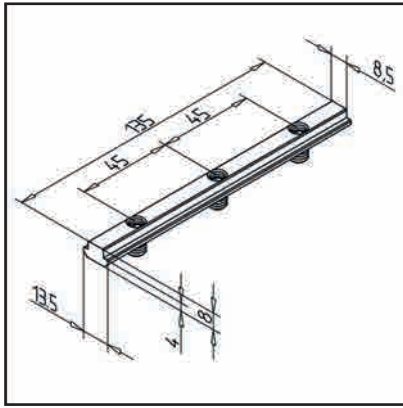
**TECHN. DATA / ITEMS SUPPLIED**

- Steel, galvanized
- 3 set screws M8, with hexagonal socket SW4
- Stainless version **part no. 21.0987/0**
- Weight = 0.094 kg/piece

**APPLICATIONS**

- Fastening rollers in standard carriages LW

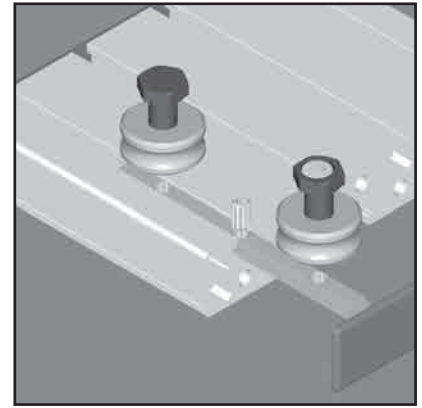
**ASSEMBLY**

- Swing into profile groove
- No machining required

T-SLOT BAR 140

Part no.

28.0026/0

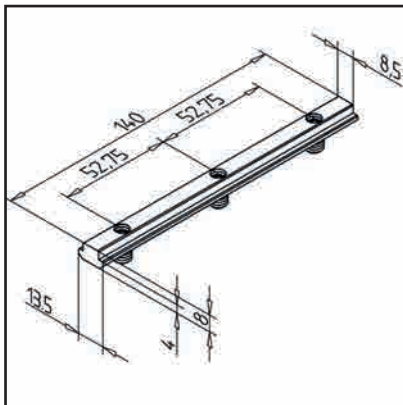
**TECHN. DATA / ITEMS SUPPLIED**

- Steel, galvanized
- 3 set screws M8, with hexagonal socket SW4
- Stainless version **part no. 28.0030/0**
- Weight = 0.096 kg/piece

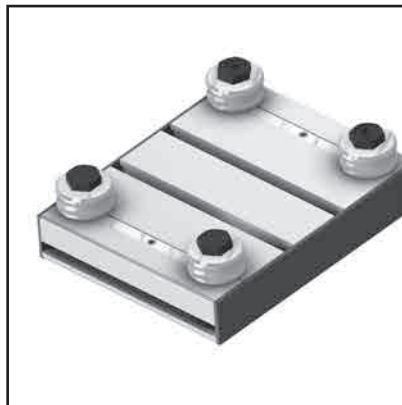
**APPLICATIONS**

- Fastening of pulleys in linear slide LW 32 E

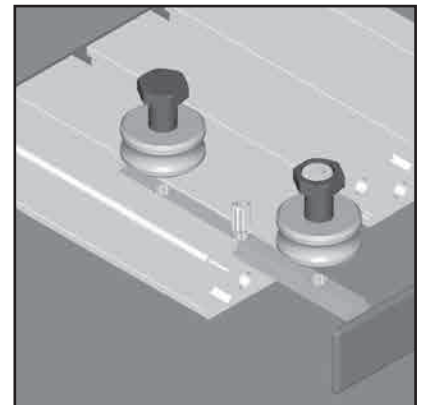
**ASSEMBLY**

- Swing into profile groove
- No machining required

T-SLOT BAR 180

Part no. 21.1101/0

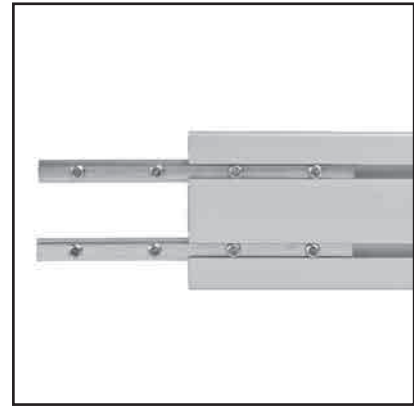
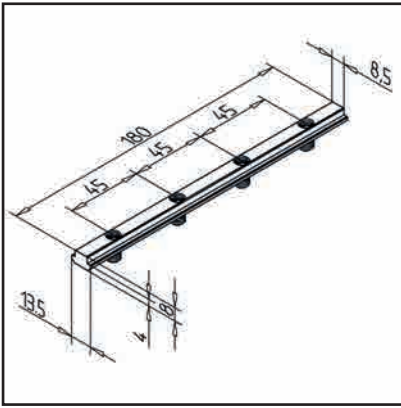

TECHN. DATA / ITEMS SUPPLIED

- Steel, galvanized
- 4 set screws M8, with hexagon socket SW4
- Stainless version **part no. 21.0986/0**
- Weight = 0.125 kg/piece

APPLICATIONS

- Front side connection at joining line
- Profile extension
- Fastening rollers in standard carriages LW

ASSEMBLY

- Swing into profile groove
- No machining required
- For larger profile cross sections or higher loads, several clamping strips must be used

T-SLOT BAR PROFILE

Part no. 21.1030/0

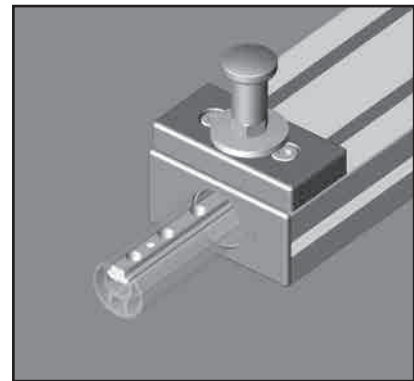
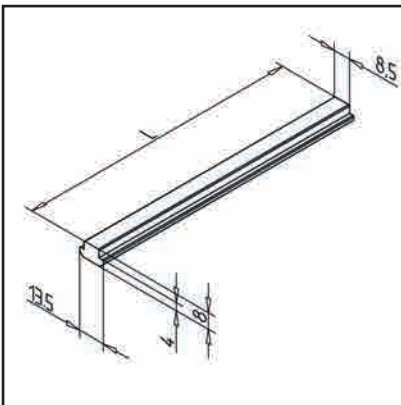

TECHN. DATA / ITEMS SUPPLIED

- Steel, bright
- Stainless version **part no. 21.1030/1**
- Weight = 0.650 kg/m
- Bar length = 3 m

APPLICATIONS

- Manufacture of terminal blocks, connecting elements in special lengths
- Production of reinforcements
- Ledges with special perforation

ASSEMBLY

- Swing into profile groove

MITRE CONNECTOR N 30

Part no.

21.0945/0

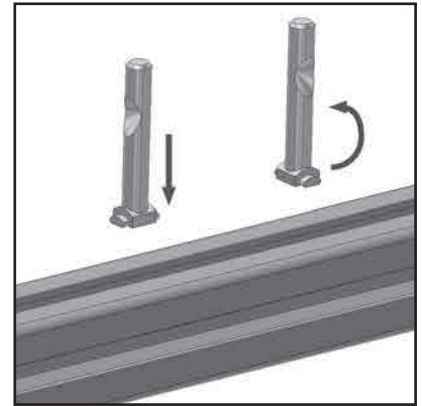
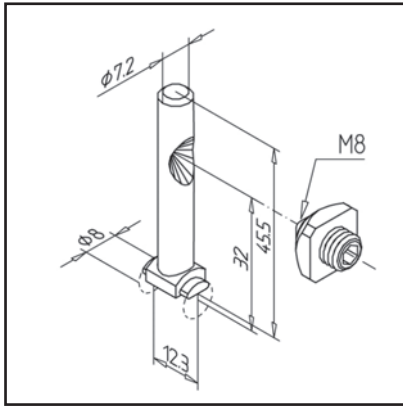
**TECHN. DATA / ITEMS SUPPLIED**

- Steel, galvanized
- With fastening material steel, zinc plated
- Weight = 0.023 kg/piece

APPLICATIONS

- Mitre connection of profiles on profile groove
- For subsequent fitting in the groove

ASSEMBLY

- Insert into groove and central bore
- Use a drilling jig for mitre connector N30
part no. 26.1056/0

MITRE CONNECTOR N 45

Part no.

21.1401/0

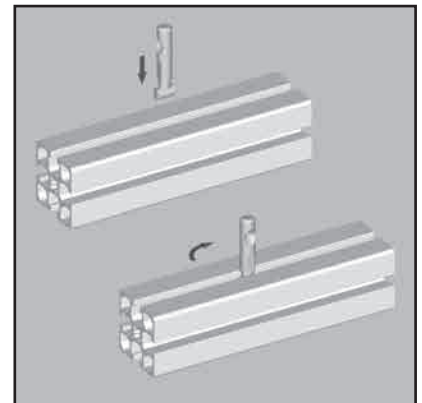
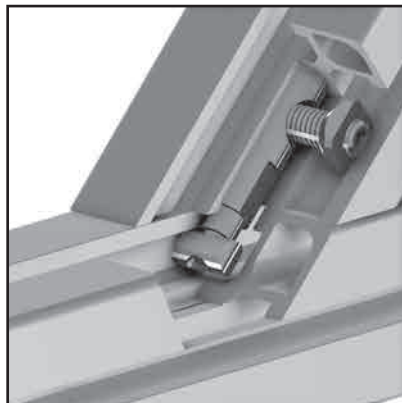
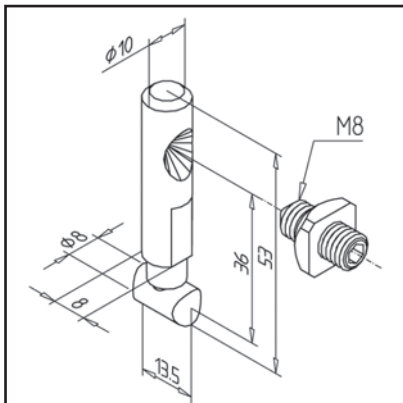
**TECHN. DATA / ITEMS SUPPLIED**

- Steel, galvanized
- With fastening material steel, zinc plated
- Weight = 0.035 kg/piece

APPLICATIONS

- Mitre connection of profiles on profile groove
- For subsequent fitting in the groove

ASSEMBLY

- Drill profile bore of $\phi 10.2$ mm
- Use a drilling jig for mitre-connector N45
part no. 26.1060/0

MITRE CONNECTOR 30

Part no. 21.1890/0

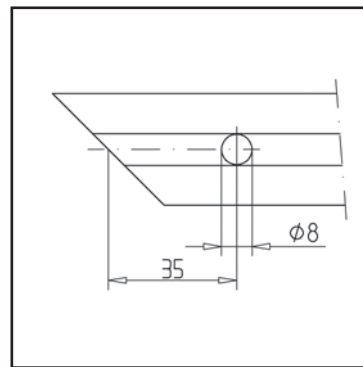
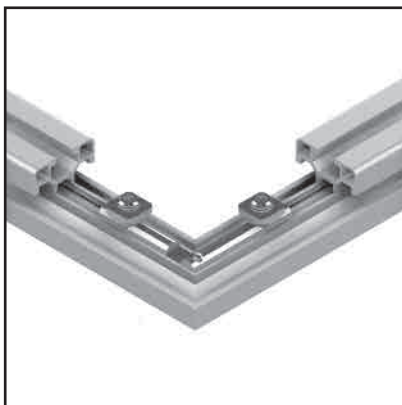
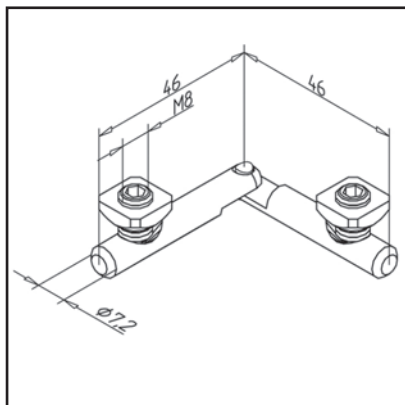

TECHN. DATA / ITEMS SUPPLIED

- Steel, galvanized
- With fastening material steel, zinc plated
- Weight = 0.040 kg/piece

APPLICATIONS

- display windows, showcases
- Store equipment
- Displays
- Frames

ASSEMBLY

- Insert the miter connector 30 into both profile ends
- Position the sliding nuts M8 above the bores and screw in the threaded pin. Attach the connector with the threaded pin M8
- Drilling jig **part no. 26.1063/0**

MITRE CONNECTOR 45

Part no. 21.1400/0

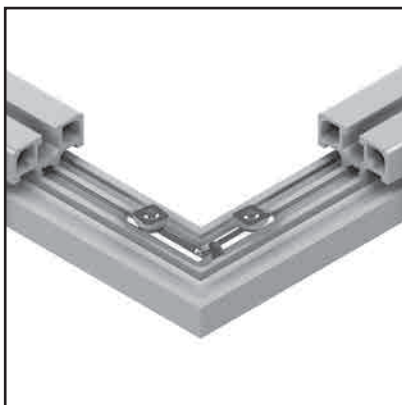
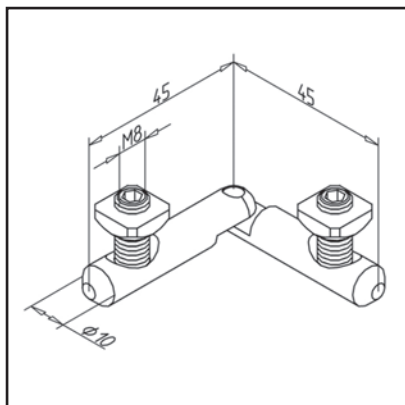

TECHN. DATA / ITEMS SUPPLIED

- Steel, galvanized
- With fastening material steel, zinc plated
- Weight = 0.065 kg/piece

APPLICATIONS

- display windows, showcases
- Store equipment
- Displays
- Frames

ASSEMBLY

- Insert the miter connector into both profile ends
- Position the sliding nuts M8 above the bores and screw in the threaded pin. Attach the connector with the threaded pin M8
- Use a drilling jig for mitre-connector 45 **part no. 26.1050/0**

MOUNTING BRACKET 30

Part no.

21.2068/0

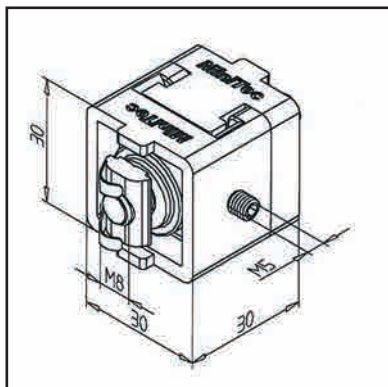

TECHN. DATA / ITEMS SUPPLIED

- PA, Injection Mould, grey
- With fastening material steel, zinc plated
- Weight = 0.041 kg/piece



APPLICATIONS

- Connection of profiles
- Profile extension
- Subsequent insertion of profiles into existing constructions, displaceable in groove direction
- Removable attachments

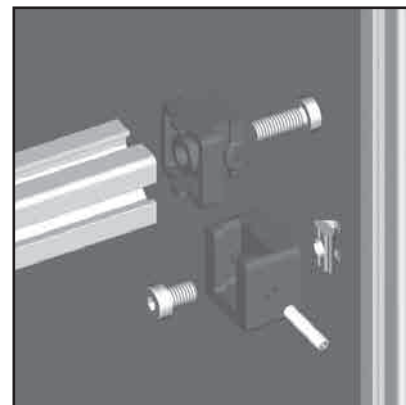

ASSEMBLY

- Fasten to profiles with supplied hardware
- Insert cross-tie profile into T-solt
- For adjustment use set screw M5

MOUNTING BRACKET 45

Part no.

21.1411/0

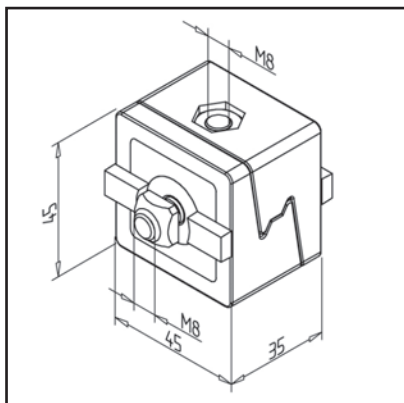

TECHN. DATA / ITEMS SUPPLIED

- Zinc, Pressure die-casting, powder-coated, grey
- With fastening material steel, zinc plated
- Weight = 0.429 kg/piece

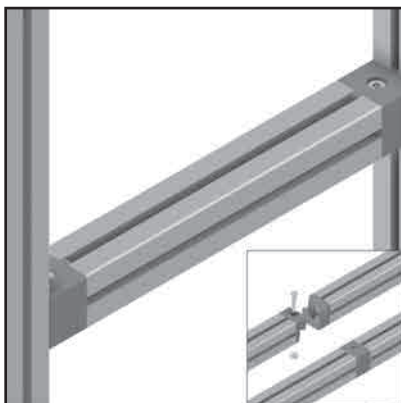

APPLICATIONS

- Connection of profiles
- Profile extension
- Subsequent insertion of profiles into existing constructions
- Attaching bearing surfaces
- Removable attachments
- Slidable in the groove direction

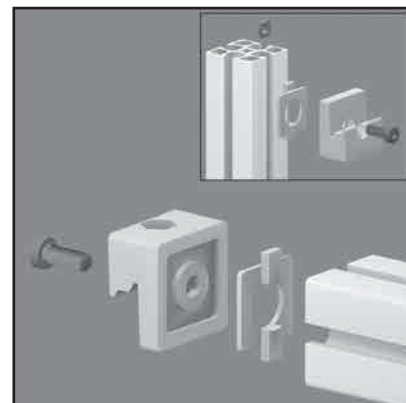

ASSEMBLY

- Fasten to profile groove with supplied hardware
- When retrofitting on a vertical groove, preferably use square nut M8 with nut fixation **part no. 21.1351/2**
- Recommended locking torque: 20 Nm

MOUNTING ANGLE 16 GD-Z

Part no.

21.2077/0

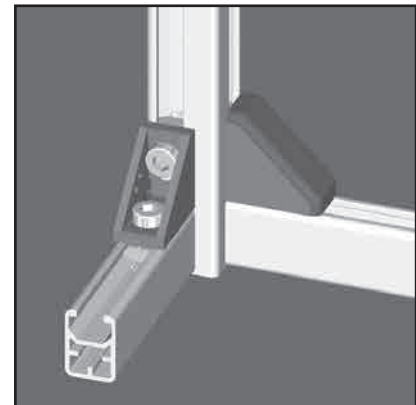
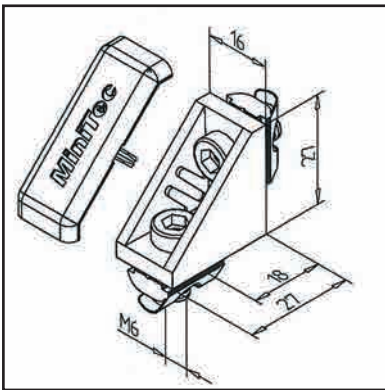

TECHN. DATA / ITEMS SUPPLIED

- Aluminium, Pressure die-casting, powder-coated, grey
- With fastening material steel, zinc plated
- Removable centering tabs
- **Conductive version part no. 21.2077/6**
- Weight = 0.021 kg/piece

APPLICATIONS

- Construction from profiles with width of 16 and 23; specifically suitable for the subsequent mounting of elements in existent constructions
- Fastening of surface elements, table tops
- Reinforcement of constructions made from profile series 16 or 23

ASSEMBLY

- Fasten to profile groove with supplied hardware
- Recommended torque: 8 Nm
- Fitting end cap MW 16 GD-Z grey, **part no. 22.1138/1**

MOUNTING ANGLE 19 GD-Z

Part no.

21.2078/0

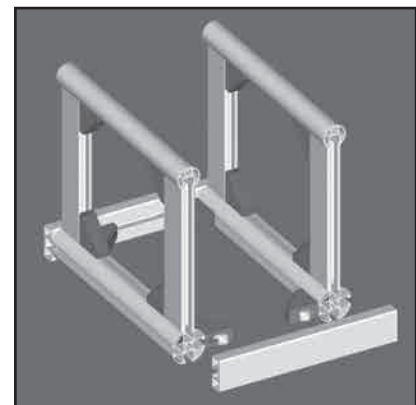
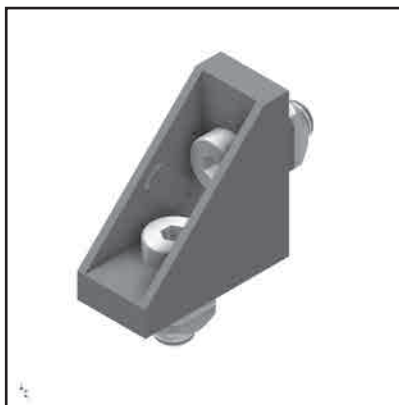
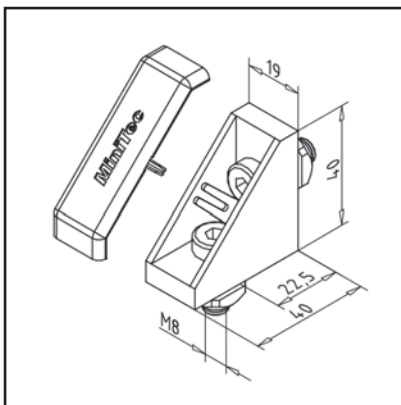

TECHN. DATA / ITEMS SUPPLIED

- Aluminium, Pressure die-casting, powder-coated, grey
- With fastening material steel, zinc plated
- Package size of 50 pieces **part no. 21.2078/050**
- **Conductive version part no. 21.2078/6**
- Use on vertical struts **part no. 21.2078/7** (square nut with position-fixing)
- Weight = 0.055 kg/piece

APPLICATIONS

- Connection of profiles 19 and 32
- Subsequent insertion of profiles into existing constructions
- Attaching bearing surfaces
- Slidable in the groove direction

ASSEMBLY

- Fasten to profile groove with supplied hardware
- Fitting end cap MW 19 GD-Z, grey, **part no. 22.1139/1**
- Recommended locking torque: 20 Nm

MOUNTING ANGLE 25 GD-Z

Part no.

21.0969/0

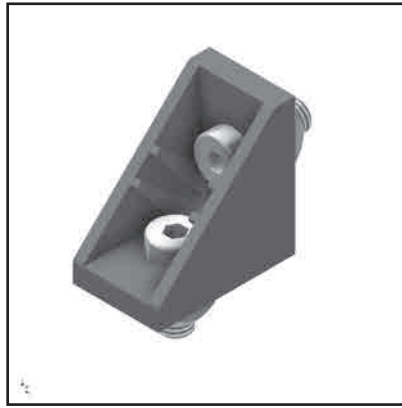
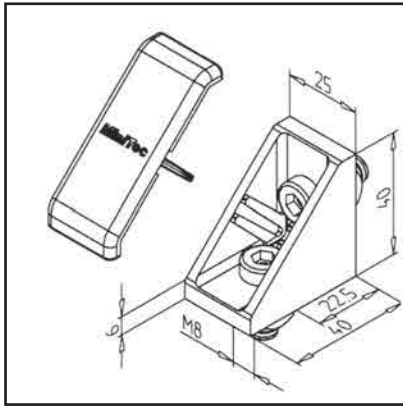
**TECHN. DATA / ITEMS SUPPLIED**

- Aluminium, Pressure die-casting, powder-coated, grey
- With fastening material steel, zinc plated
- Removable centering tabs
- Package size of 50 pieces **part no. 21.0969/050**
- **Conductive version part no. 21.0969/6**
- Use on vertical struts **part no. 21.0969/7** (square nut with position-fixing)
- Weight = 0.066 kg/piece

APPLICATIONS

- General constructions, particularly for subsequent insertion of profiles into existing constructions
- Fastening of surface elements, table tops
- Strengthening of profile constructions

ASSEMBLY

- Fasten to profile groove with supplied hardware
- If non-aligning grooves, break centering tabs with pliers
- Fitting end cap MW 25 GD-Z, **part no. 22.0997/1**
- Recommended locking torque: 20 Nm

MOUNTING ANGLE 25 S

Part no.

21.1134/0

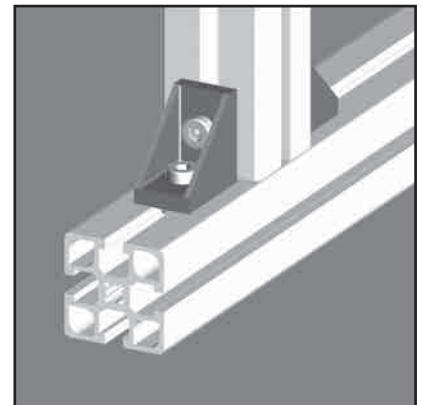
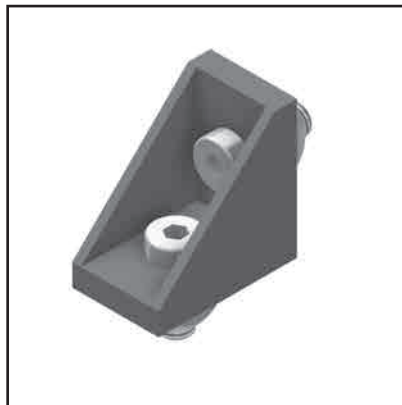
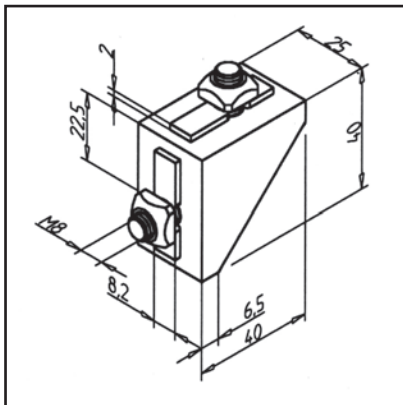
**TECHN. DATA / ITEMS SUPPLIED**

- Aluminium, Pressure die-casting, powder-coated, grey
- With fastening material steel, zinc plated
- With ridge as anti-twist device
- Package size of 50 pieces **part no. 21.1134/050**
- **Conductive version part no. 21.1134/6**
- Use on vertical struts **part no. 21.1134/7** (square nut with position-fixing)
- Weight = 0.067 kg/piece

APPLICATIONS

- General constructions, particularly for subsequent insertion of profiles into existing constructions
- Strengthening of profile constructions

ASSEMBLY

- Fasten to profile groove with supplied hardware
- Recommended locking torque: 20 Nm

MOUNTING ANGLE 30 GD

Part no. 21.0905/0

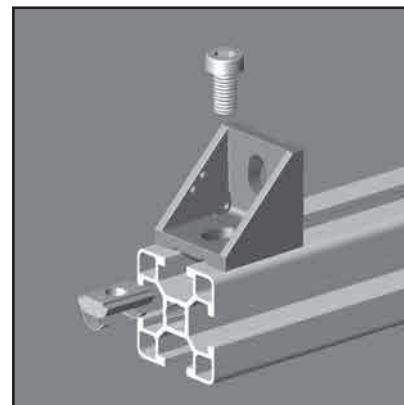
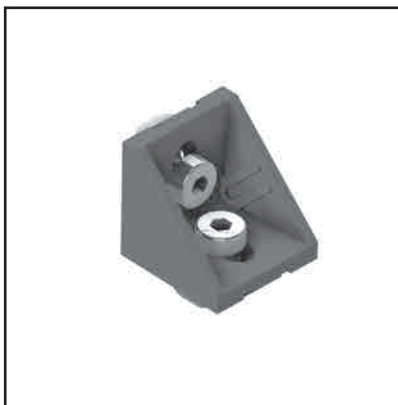
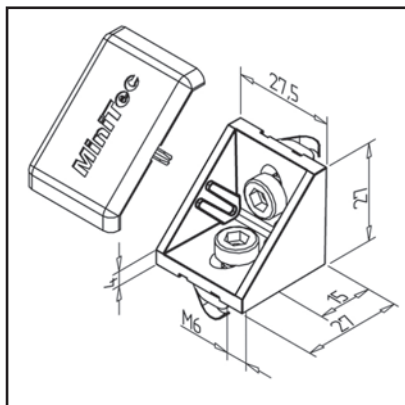

TECHN. DATA / ITEMS SUPPLIED

- Aluminium, Pressure die-casting, powder-coated, grey
- With fastening material steel, zinc plated
- Removable centering tabs
- Package size of 50 pieces **part no. 21.0905/050**
- conductive version **part no. 21.0905/6**
- Weight = 0.029 kg/piece

APPLICATIONS

- All types of constructions; specifically suited for the subsequent mounting of elements in existing constructions
- Fastening of surface elements, table tops

ASSEMBLY

- Strengthening of profile constructions
- Fasten to profile groove with supplied hardware
- Recommended torque: 8 Nm
- Fitting end cap MW 30 grey, **part no. 22.0989/1**

MOUNTING ANGLE 45 GD

Part no. 21.1133/0

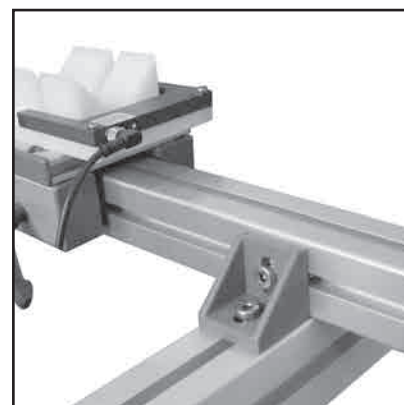
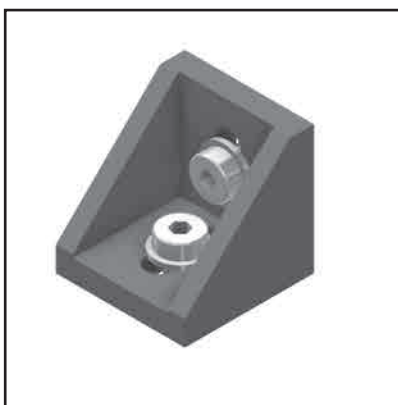
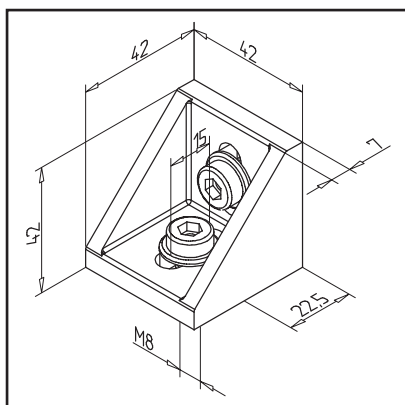

TECHN. DATA / ITEMS SUPPLIED

- Aluminium, Pressure die-casting, powder-coated, grey
- With fastening material steel, zinc plated
- Package size of 50 pieces **part no. 21.1133/050**
- **Conductive version part no. 21.1133/6**
- Use on vertical struts **part no. 21.1133/7** (square nut with position-fixing)
- Weight = 0.114 kg/piece

APPLICATIONS

- General constructions, particularly for subsequent insertion of profiles into existing constructions
- Fastening of surface elements, table tops
- Strengthening of profile constructions

ASSEMBLY

- Fasten to profile groove with supplied hardware
- Hammer head screw **part no. 21.1370/0** can be used
- Recommended locking torque: 20 Nm

MOUNTING ANGLE 30 R 90°

Part no.

21.2109/0

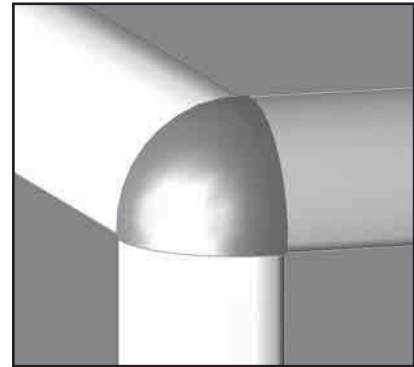
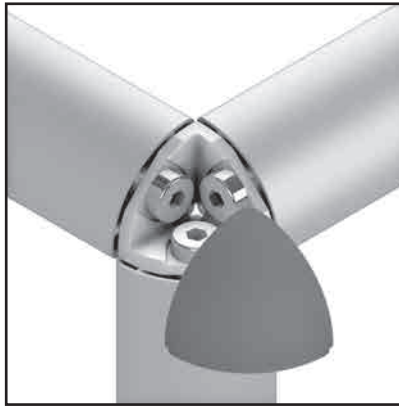
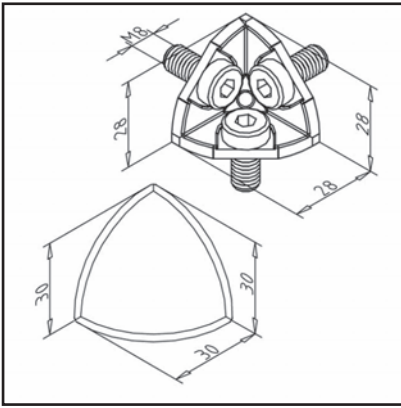

TECHN. DATA / ITEMS SUPPLIED

- Aluminium, Pressure die-casting, bright
- With fastening material steel, zinc plated
- End cap MW 30 R 90° **part no. 22.1143/1**
- Weight = 0.043 kg/piece

APPLICATIONS

- Corner fastening of profiles 30 R 90°
- Constructions for show cases, tables etc.

ASSEMBLY

- in the central bore of the profile with supplied hardware
- Clip the end cap

MOUNTING ANGLE 45 R 90°

Part no.

21.1710/1

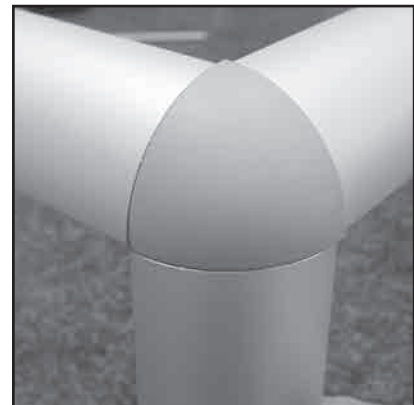
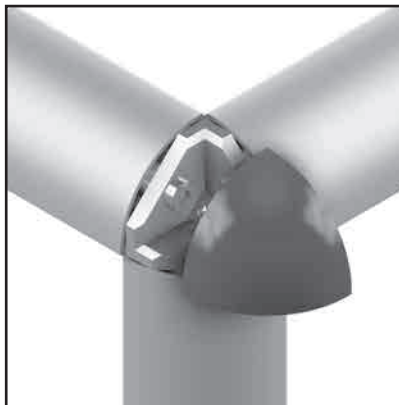
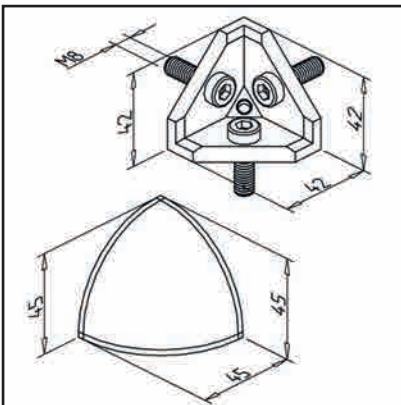

TECHN. DATA / ITEMS SUPPLIED

- Aluminium, Pressure die-casting, bright
- With fastening material steel, zinc plated
- End cap MW 45 R 90° **part no. 22.1033/1**
- Weight = 0.098 kg/piece

APPLICATIONS

- Corner fastening of profiles 45 R 90°
- Constructions for show cases, tables etc.

ASSEMBLY

- in the central bore of the profile with supplied hardware
- Clip the end cap

MOUNTING ANGLE 45°

Part no.

21.1708/1

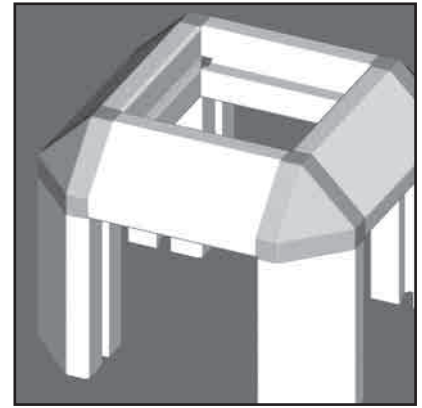
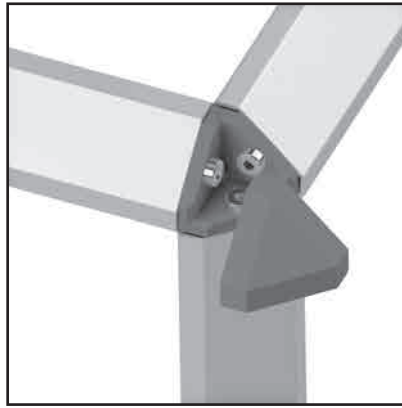
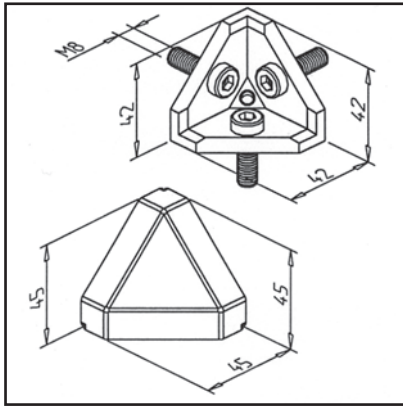
**TECHN. DATA / ITEMS SUPPLIED**

- Aluminium, Pressure die-casting, bright
- With fastening material steel, zinc plated
- End cap 45°/3, grey **part no. 22.1027/1**
- Weight = 0.107 kg/piece

APPLICATIONS

- Corner fastening of profiles 45 / 45°
- Constructions for show cases, tables etc.

ASSEMBLY

- in the central bore of the profile with supplied hardware
- Clip the end cap

MOUNTING ANGLE 45 G

Part no.

21.2503/1

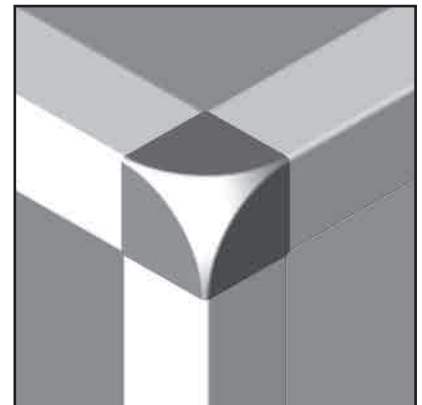
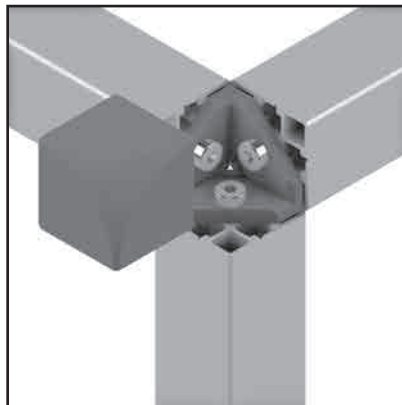
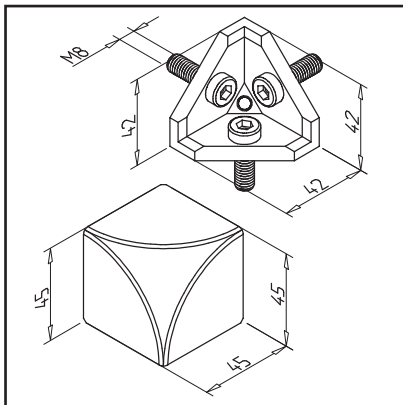
**TECHN. DATA / ITEMS SUPPLIED**

- Aluminium, Pressure die-casting, bright, grey
- With fastening material steel, zinc plated
- End cap MW 45/45/45 grey **part no. 22.1177/1**
- Weight = 0.121 kg/piece

APPLICATIONS

- Constructions for show cases, tables etc.
- Connection of profiles 45x45, preferably G-profile

ASSEMBLY

- Fasten to central profile bore with fixation material from delivery scope
- Clip the end cap

MOUNTING ANGLE 45 X 90 GD-Z

Part no. 21.1397/0

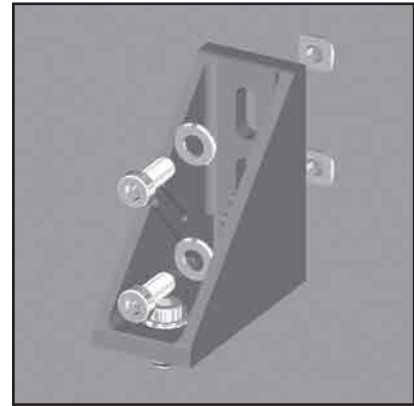
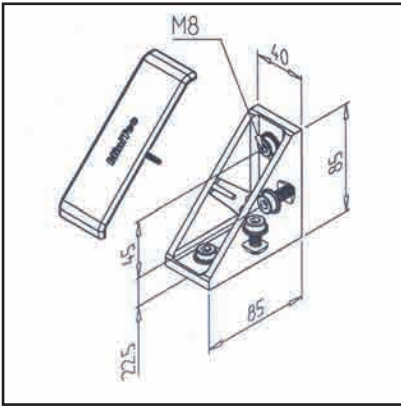

TECHN. DATA / ITEMS SUPPLIED

- Aluminium, Pressure die-casting, powder-coated, grey
- With fastening material steel, zinc plated
- Package size of 25 pieces **part no.. 21.1397/025**
- **Conductive version part no. 21.1397/6**
- Use on vertical struts **part no. 21.1397/7** (square nut with position-fixing)
- Weight = 0.281 kg/piece

APPLICATIONS

- General constructions, particularly for subsequent insertion of profiles into existing constructions
- Fastening of surface elements, table tops
- Strengthening of profile constructions

ASSEMBLY

- Fasten to profile groove with supplied hardware
- Hammer head screw **part no. 21.1370/0** can be used
- Fitting end cap MW 45 x90 GD-Z, **part no. 22.0998/1**
- Recommended locking torque: 20 Nm

MOUNTING ANGLE 90 GD-Z

Part no. 21.0978/0

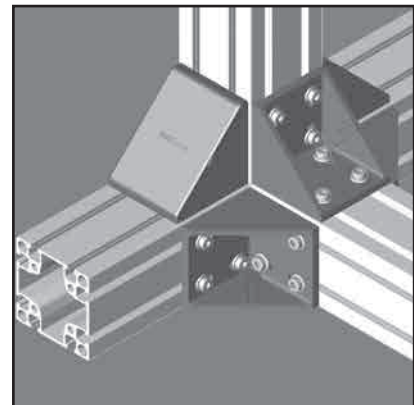
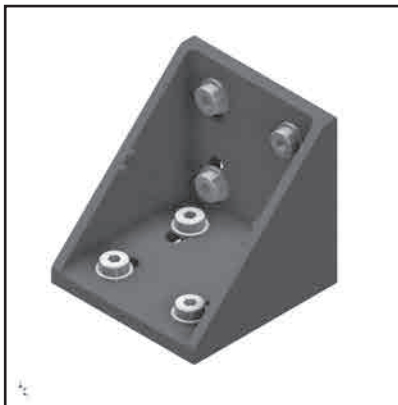
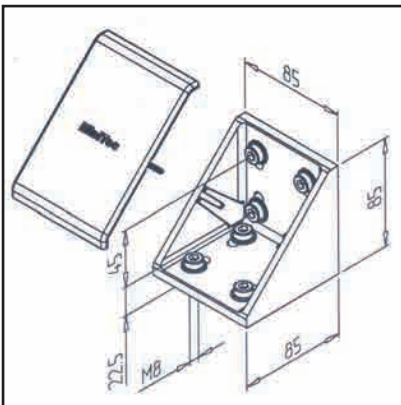

TECHN. DATA / ITEMS SUPPLIED

- Aluminium, Pressure die-casting, powder-coated, grey
- With fastening material steel, zinc plated
- Package size of 25 pieces **part no.. 21.0978/025**
- **Conductive version part no. 21.0978/6**
- Use on vertical struts **part no. 21.0978/7** (square nut with position-fixing)
- Weight = 0.497 kg/piece

APPLICATIONS

- For profiles 90 and 180
- General constructions, particularly for subsequent insertion of profiles into existing constructions
- Strengthening of profile constructions

ASSEMBLY

- Fasten to profile groove with supplied hardware
- Hammer head screw **part no. 21.1370/0** can be used
- Matching cap MW 90 GD-Z **part-No. 22.0999/1**
- Recommended locking torque: 20 Nm

CORNER CONNECTION 90 R 90°

Part no.

21.2199/0

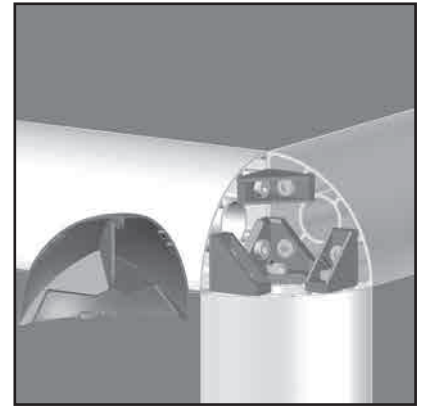
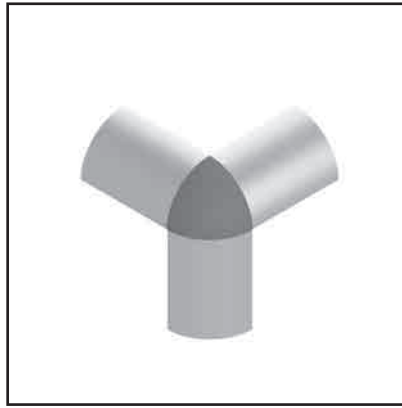
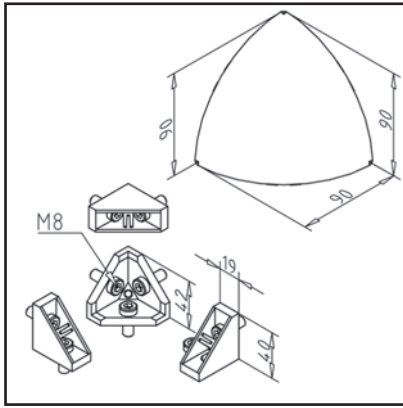
**TECHN. DATA / ITEMS SUPPLIED**

- Aluminium, Pressure die-casting, bright
- With fastening material steel, zinc plated
- End cap MW 90 R 90° **part no. 22.0980/1**
- Angle 45°, **part no. 21.1708/2**
- Mounting bracket 19 GD-Z, **part no. 21.2078/2**
- Weight = 0.267 kg/piece

APPLICATIONS

- Corner connections of profiles 90 R 90°
- Constructions for show cases, tables etc.

ASSEMBLY

- Fasten to central profile bore with fixation material from delivery scope
- Clip the end cap

T-SHEET SST

Part no.

21.0019/0

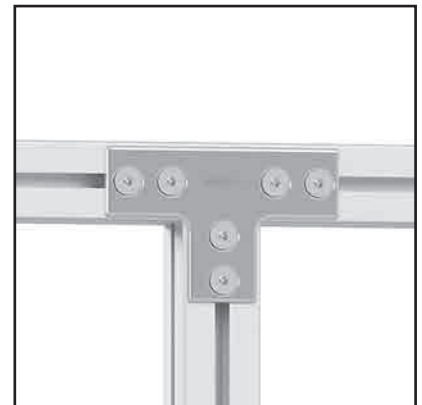
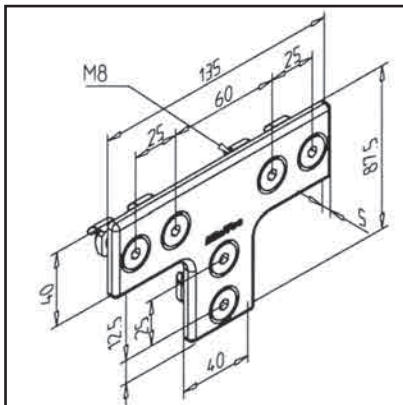
**TECHN. DATA / ITEMS SUPPLIED**

- Stainless steel, blasted
- Fastening kit
- Weight = 0.259 kg/piece

APPLICATIONS

- Strengthening of profile constructions

ASSEMBLY

- Attach to the profile with supplied hardware
- Use power-lock fasteners if tractive forces appear

ANGLE-SHEET SST

Part no.

21.0018/0

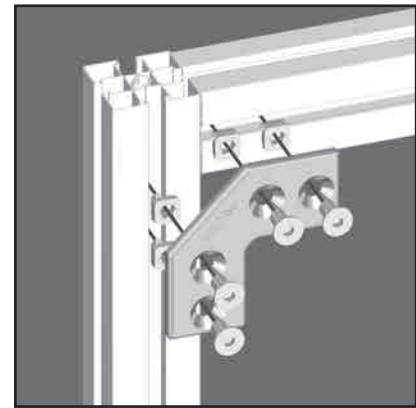
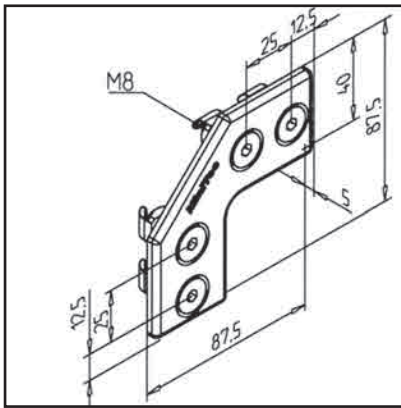
**TECHN. DATA / ITEMS SUPPLIED**

- Stainless steel, blasted
- Fastening kit
- Weight = 0.163 kg/piece

APPLICATIONS

- Strengthening of profile constructions
- Also suitable for cross joints (double application)

ASSEMBLY

- Attach to the profile with supplied hardware
- Use power-lock fasteners if tractive forces appear

MULTI CONNECTOR 30

Part no.

22.1140/0

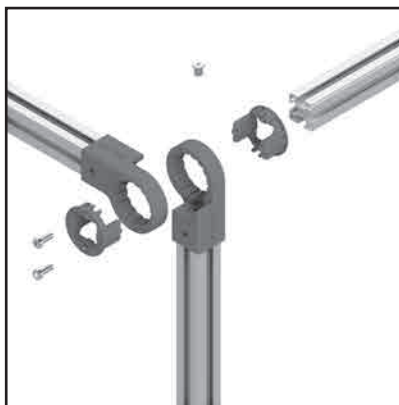
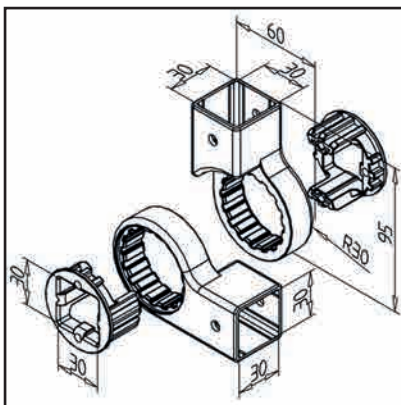
**TECHN. DATA / ITEMS SUPPLIED**

- ABS, Injection Mould, grey
- With fastening material steel, zinc plated
- Weight = 0.135 kg/piece

APPLICATIONS

- Easy connection for profiles
- Angle adjustable in 22,5° raster

ASSEMBLY

- Fix swivel arm front to profile
- Insert socket from the side
- Insert other profile into socket and position it
- Secure with 2 cylinder screws against moving

ADAPTER G32 / G32

Part no.

21.0954/0

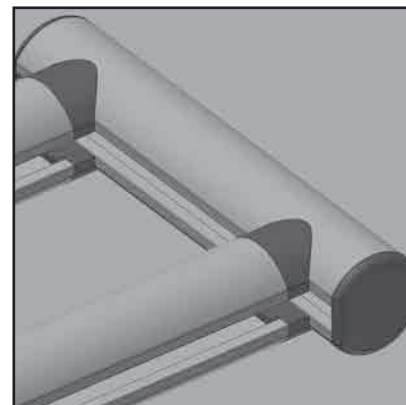
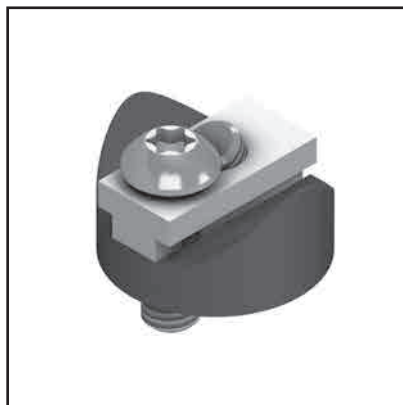
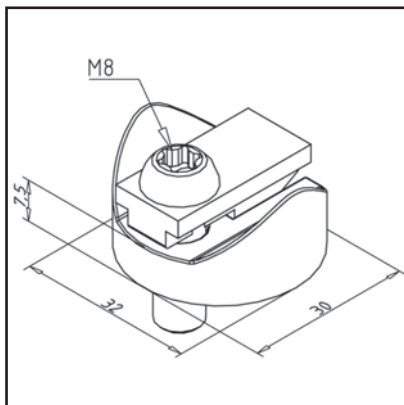
**TECHN. DATA / ITEMS SUPPLIED**

- Aluminium, Pressure die-casting, powder-coated, grey
- With fastening material steel, zinc plated
- Weight = 0.041 kg/piece

APPLICATIONS

- For connection of handle profile 32 with handle profile 32

ASSEMBLY

- Screw on profile face and fasten with power-lock fastener
- Push in cross direction profile and attach it to the desired location

ADAPTER G32 / 30 X 30

Part no.

21.0955/0

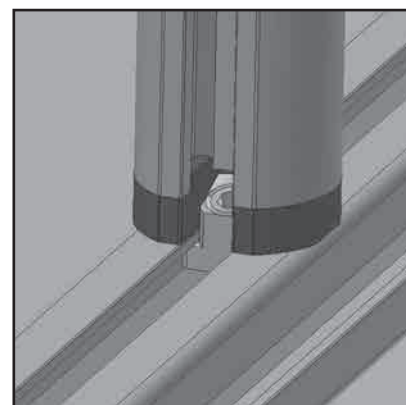
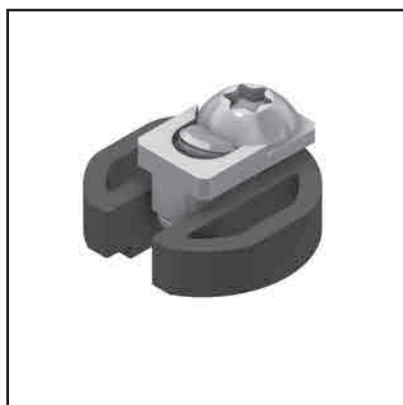
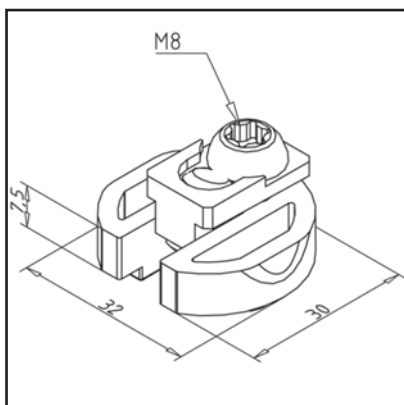
**TECHN. DATA / ITEMS SUPPLIED**

- Aluminium, Pressure die-casting, powder-coated, grey
- With fastening material steel, zinc plated
- Weight = 0.032 kg/piece

APPLICATIONS

- For connection of handle profile 32 with profiles of width 30

ASSEMBLY

- Screw on profile face and fasten with power-lock fastener
- Push in cross direction profile and attach it to the desired location

ADAPTER 30 X 30 / G32

Part no.

21.0953/0

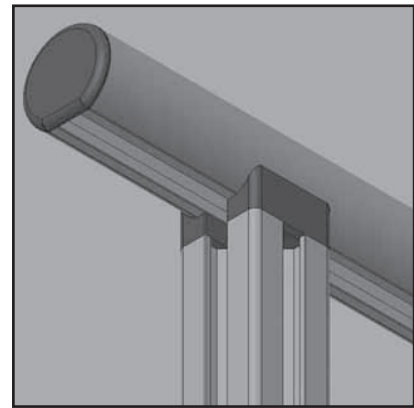
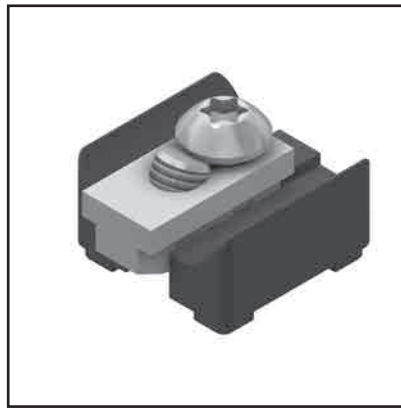
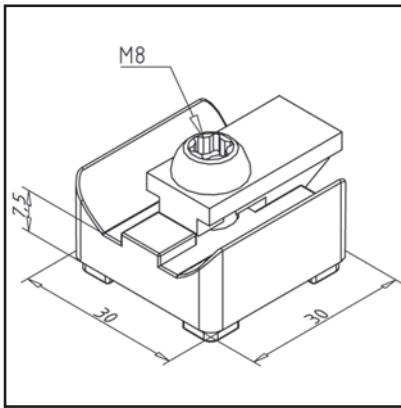

TECHN. DATA / ITEMS SUPPLIED

- Aluminium, Pressure die-casting, powder-coated, grey
- With fastening material steel, zinc plated
- Weight = 0.046 kg/piece

APPLICATIONS

- For connection of profile 30 x 30 with handle profile 32

ASSEMBLY

- Screw on profile face and fasten with power-lock fastener
- Push in cross direction profile and attach it to the desired location

CONNECTING BAR

Part no.

21.1113/0

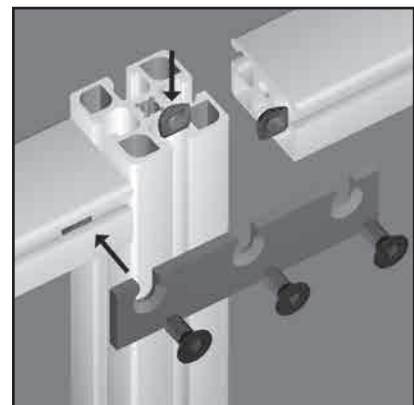
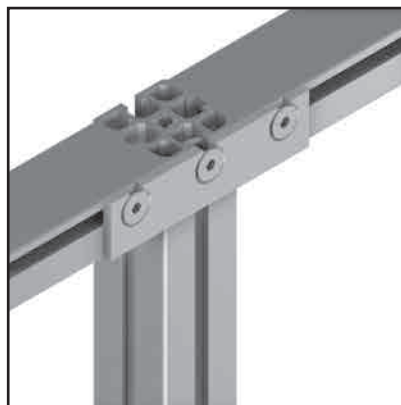
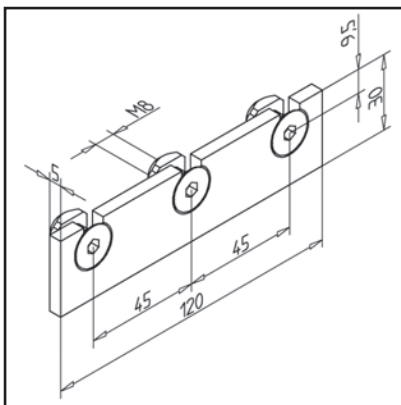

TECHN. DATA / ITEMS SUPPLIED

- Steel, galvanized
- With fastening material steel, zinc plated
- Weight = 0.156 kg/piece

APPLICATIONS

- Connection of different profiles
- Retrofitting profiles

ASSEMBLY

- Fasten to profile groove with supplied hardware
- No machining required

PROTECTIVE FIELD SUSPENSION 45 ST

Part no.

21.1404/0

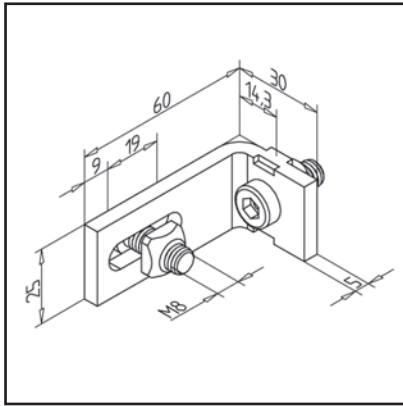

TECHN. DATA / ITEMS SUPPLIED

- Steel, galvanized
- With fastening material steel, zinc plated
- Weight = 0.104 kg/piece

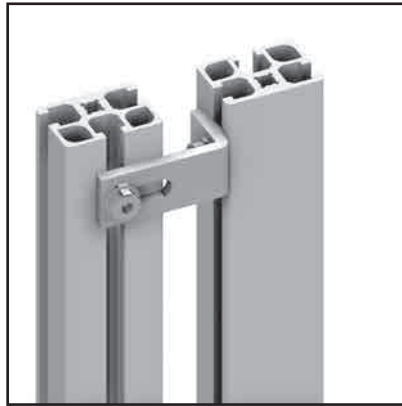

APPLICATIONS

- Fixation of guard units from profile 45 x 32
- Usable in frames made from any profile
- The protective field flush fits to the column

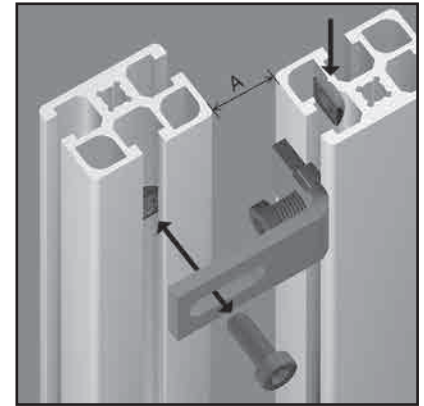

ASSEMBLY

- Fasten to profile groove with supplied hardware
- No machining required
- First attach the brackets to the standing profile, then connect the protective field from the rear to the brackets
- A = 10 mm - 28 mm

PROTECTIVE FIELD SUSPENSION 19

Part no.

21.1399/0

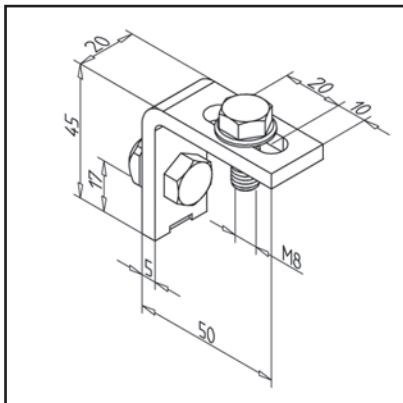

TECHN. DATA / ITEMS SUPPLIED

- Steel, galvanized
- With fastening material steel, zinc plated
- Weight = 0.089 kg/piece

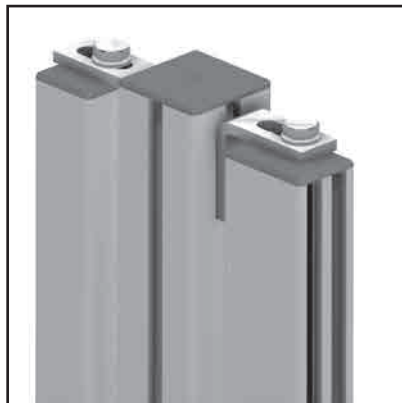

APPLICATIONS

- Fastening protective fields from clamping profile 32 x 32, 45 x 32 or standard profiles
- Attachment of protective fields at any angle
- When using clamping profile 32x32 use end cap **part no. 22.1032/3**
- When using clamping profile 45x32 use end cap **part no. 22.1046/3**

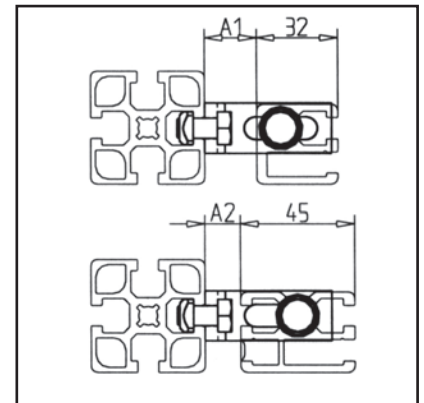

ASSEMBLY

- Spread screw threads M8 x 20 into the profile ending of the protective field
- Install protective field suspension on posts
- Fix guard with screws of fastening kit
- Alternatively: For very fast assembly, the lower two threads can be fitted with the retaining pin 25 **part no. 21.1758/0**. Screw fastening only on the two upper threads
- A1 = 10.5 mm - 30.5 mm A2 = 10.5 mm - 17.5 mm

PROTECTIVE FIELD SUSPENSION 45 AL

Part no.

21.1407/0

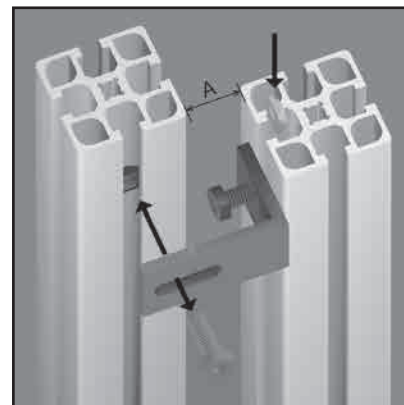
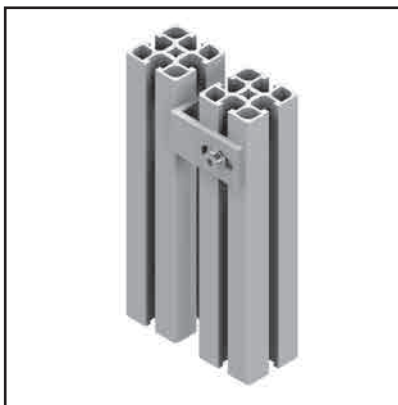
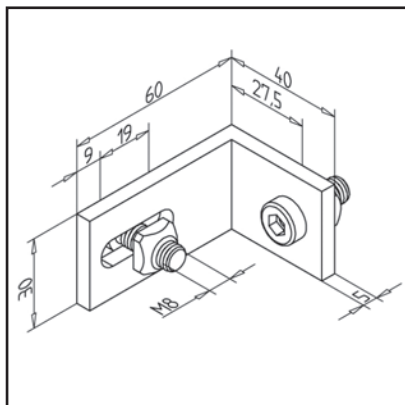

TECHN. DATA / ITEMS SUPPLIED

- Aluminium, anodized E6/EV1
- With fastening material steel, zinc plated
- Weight = 0.068 kg/piece

APPLICATIONS

- Fixation of guard units from profile 45 x 45
- Usable in frames made from any profile
- The protective field flush fits to the column

ASSEMBLY

- Fasten to profile groove with supplied hardware
- No machining required
- First attach the brackets to the standing profile, then connect the protective field from the rear to the brackets
- A = 10 mm - 28 mm

PROTECTIVE FIELD SUSPENSION GD-K

Part no.

21.0008/0

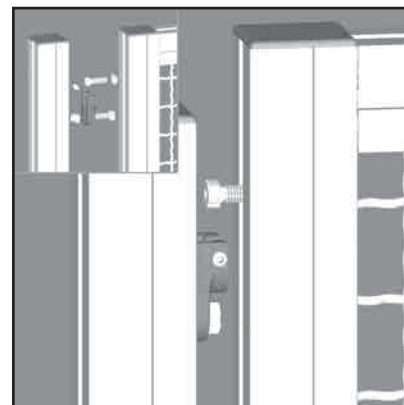
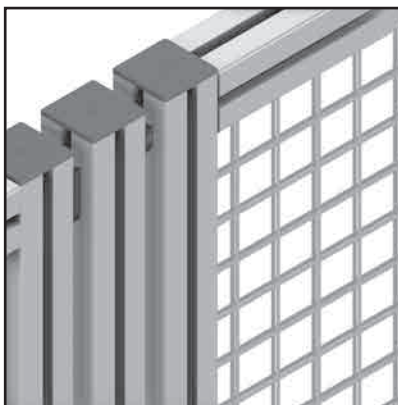
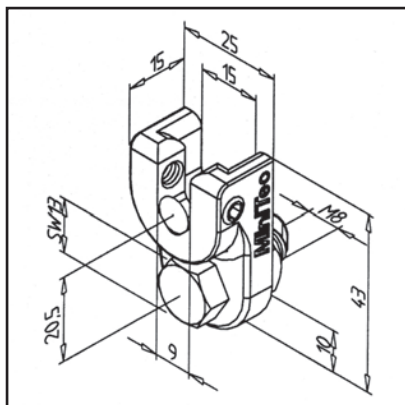

TECHN. DATA / ITEMS SUPPLIED

- Aluminium, Pressure die-casting, powder-coated, grey
- With fastening material steel, zinc plated
- Weight = 0.039 kg/piece

APPLICATIONS

- Guards from all profiles
- Movable flaps
- It is also possible to mount the guards at the front when fitting the suspensions to the front of the post

ASSEMBLY

- Fasten protective field hanger assembly in place on columns
- Guard unit with cylinder screws M8 x 25 furnished
- Hang the guard in place, and tighten the set screw using an Allen key from the rear
- A = 16 mm ± 0.75
- **Guard cannot be removed from outside**

PROTECTIVE FIELD SUSPENSION WITH ADJUSTABLE ANGLE

Part no.

21.1403/0

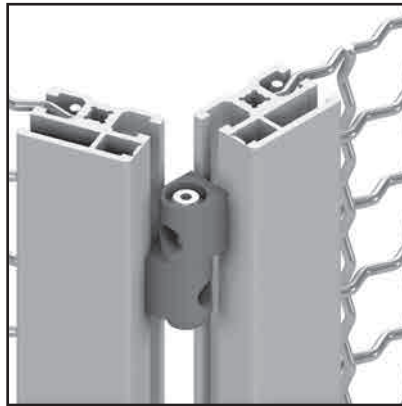
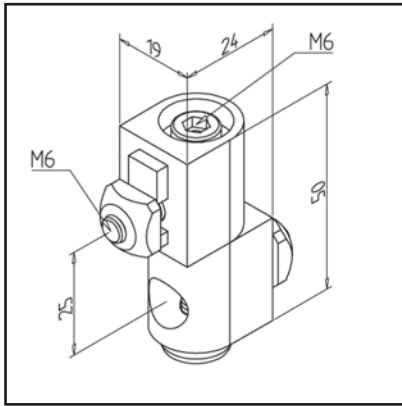

TECHN. DATA / ITEMS SUPPLIED

- Aluminium, Pressure die-casting, powder-coated, grey
- With fastening material steel, zinc plated
- Weight = 0.114 kg/piece

APPLICATIONS

- Connection of profile support under preferred angle
- Installation of safety fence elements at any angle

ASSEMBLY

- Assemble and align lower halves onto posts
- Assemble and mount upper halves on guard unit
- Insert the cylinder head screw and tighten it with key 4 A/F. The inserted hexagon nut in the lower fixing half is secured against torsion

CONNECTING PLATE 30 X 60

Part no.

21.2113/0

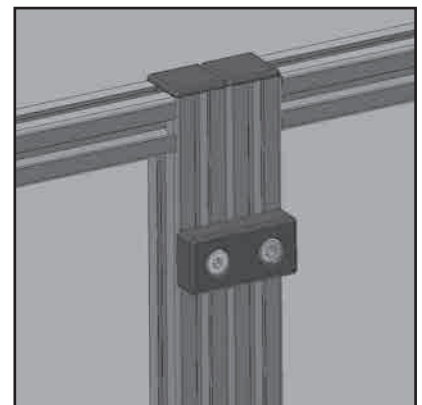
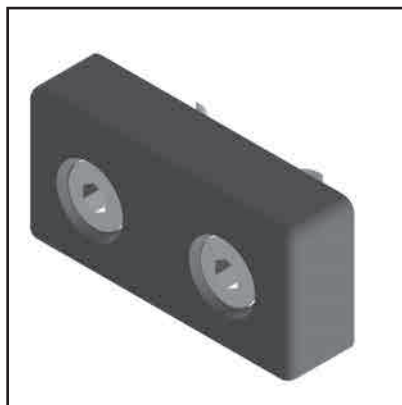
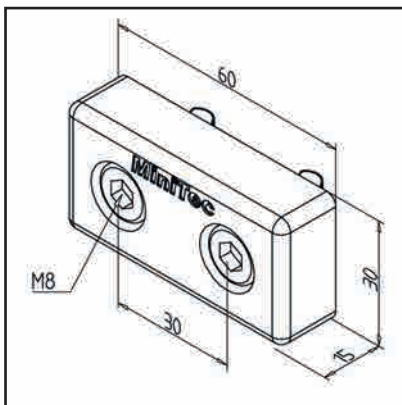

TECHN. DATA / ITEMS SUPPLIED

- Aluminium, Pressure die-casting, powder-coated, grey
- With fastening material steel, zinc plated
- Weight = 0.085 kg/piece

APPLICATIONS

- Connection of two guards without gap
- Strengthening of guard units
- Connection of pre-assembled modules

ASSEMBLY

- Install to groove of protective field and posts with supplied hardware

CONNECTING PLATE 90 X 32

Part no.

21.1346/0

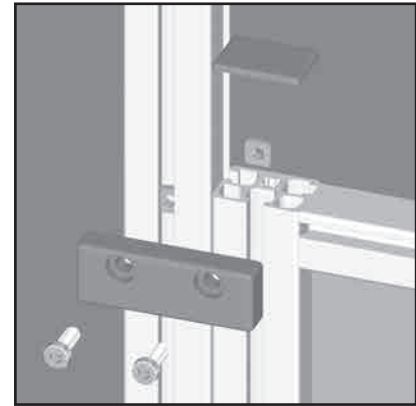
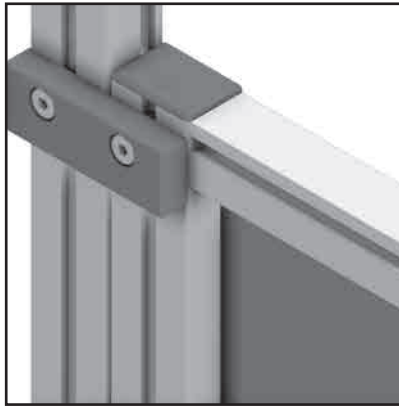
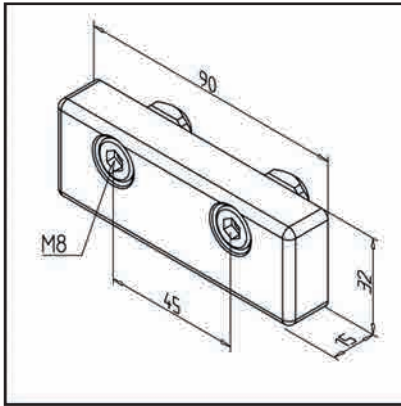

TECHN. DATA / ITEMS SUPPLIED

- Aluminium, Pressure die-casting, powder-coated, grey
- With fastening material steel, zinc plated
- Weight = 0.136 kg/piece

APPLICATIONS

- Connection of two guards without gap
- Strengthening of guard units
- Connection of pre-assembled modules

ASSEMBLY

- Install to groove of protective field and posts with supplied hardware

CONNECTING PLATE 45 X 90

Part no.

21.1472/0

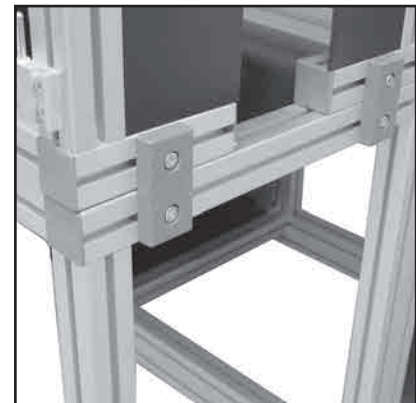
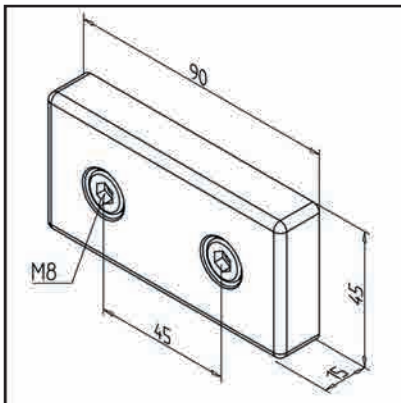

TECHN. DATA / ITEMS SUPPLIED

- Aluminium, Pressure die-casting, powder-coated, grey
- With fastening material steel, zinc plated
- Weight = 0.182 kg/piece

APPLICATIONS

- Connection of two guards without gap
- Strengthening of guard units
- Connection of pre-assembled modules

ASSEMBLY

- Install to groove of protective field and posts with supplied hardware

CONNECTING PLATE 90 X 90

Part no.

21.1473/0

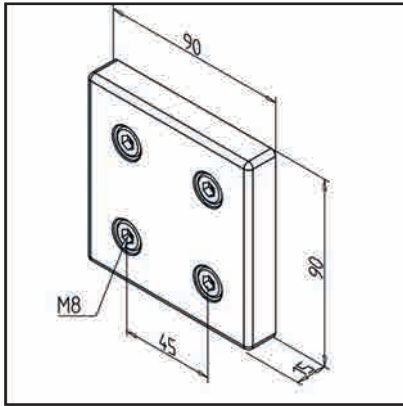
**TECHN. DATA / ITEMS SUPPLIED**

- Aluminium, Pressure die-casting, powder-coated, grey
- With fastening material steel, zinc plated
- Weight = 0.366 kg/piece

**APPLICATIONS**

- Connection of two guards without gap
- Strengthening of guard units
- Connection of pre-assembled modules

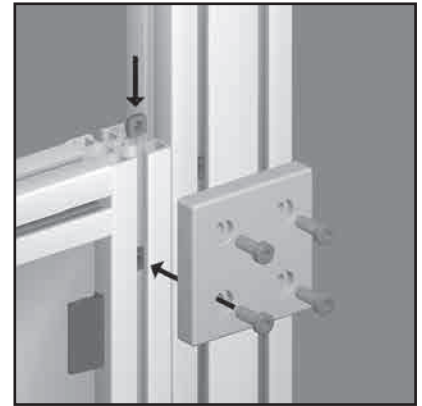
**ASSEMBLY**

- Install to groove of protective field and posts with supplied hardware

CLAMPING CLAW

Part no.

21.1027/0

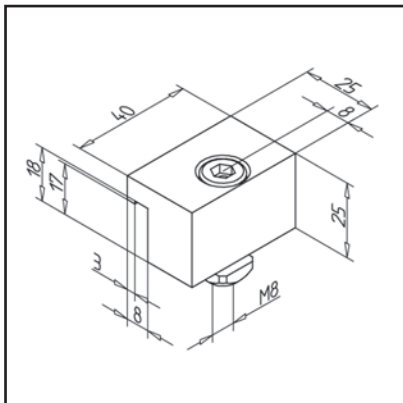
**TECHN. DATA / ITEMS SUPPLIED**

- Aluminium, anodized E6/EV1
- With fastening material steel, zinc plated
- Weight = 0.063 kg/piece

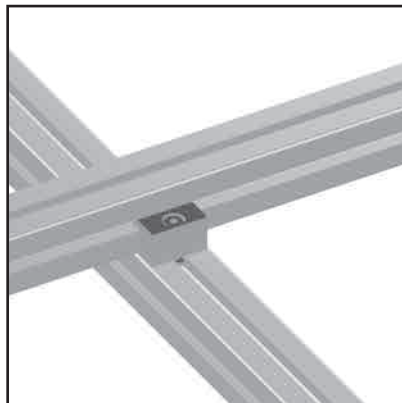
**APPLICATIONS**

- Parallel connection of profiles at various angles

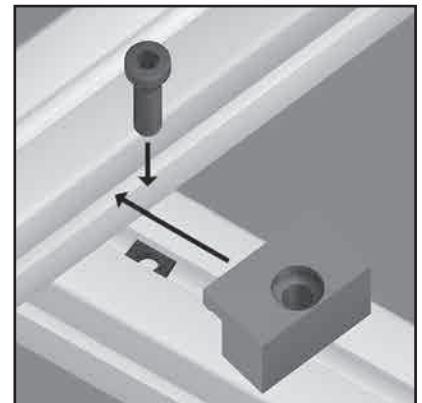
**ASSEMBLY**

- Fasten to profile groove with supplied hardware
- No machining required