

# Positioning system DLZPVI 120, 160, 200

## Belt drive

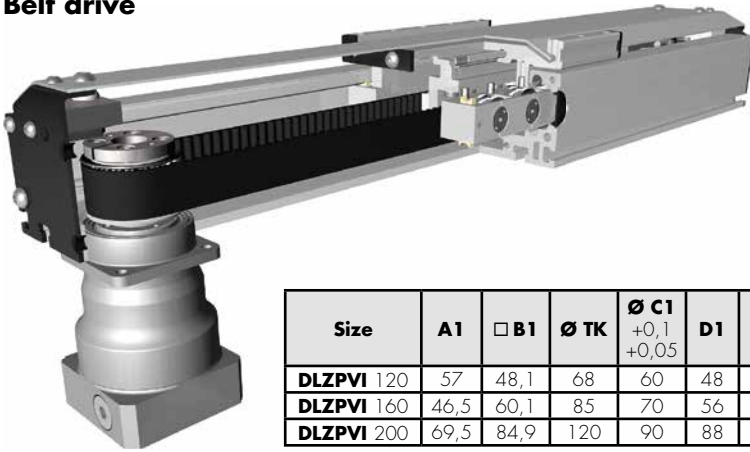

Size	A1	□ B1	∅ TK	∅ C1 +0,1 +0,05	D1	E1	F1
DLZPVI 120	57	48,1	68	60	48	16	M5
DLZPVI 160	46,5	60,1	85	70	56	22	M6
DLZPVI 200	69,5	84,9	120	90	88	32	M8

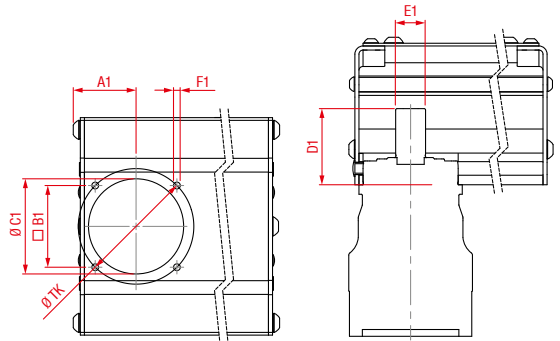

### Function:

This unit consists of a rectangular aluminium profile with 2 integrated roller guides. The carriage is moved by a belt drive. On the drive side the pulley is beared on the shaft of a planetary gear. Belt tension can be readjusted by a simple screw adjustment at the opposite side of the drive. A special curved aluminium sheet is covering the carriage side. There is only a small gap between carriage and aluminium sheet. Because of its special design it is possible to drive the carriage over the pulley areas. This fact is making the unit very compact. The cover profile can be adjusted according to the mounting position.

### Fitting position:

As required, max. length DLZPVI 120 / 1600mm, DLZPVI 160 / 1800mm, DLZPVI 200 / 2000mm

### Carriage mounting:

By tapped holes.

### Unit mounting:

T-slots

### Belt type:

HTD with steel reinforcement, no backlash when changing direction, repeatability ± 0,1 mm.

### Carriage support:

In the standard version, the carriage runs on 4 runner blocks which can be serviced at a central servicing position. For longer carriages the number of runner blocks can be increased.

8.1

Forces and torques	Size	120		160		200	
	Forces/Torques	static	dynamic	static	dynamic	static	dynamic.
	F <sub>x</sub> (N)	894	800	1900	1800	4000	3800
	F <sub>y</sub> (N)	1100	900	3000	2000	4400	3100
	F <sub>z</sub> (N)	1250	1000	3500	2800	4900	4400
	M <sub>x</sub> (Nm)	150	125	400	320	600	510
	M <sub>y</sub> (Nm)	140	120	360	300	560	480
	M <sub>z</sub> (Nm)	100	90	180	150	310	275
<b>All forces and torques related to the following:</b>							
existing values $\frac{F_y}{F_{y_{dyn}}} + \frac{F_z}{F_{z_{dyn}}} + \frac{M_x}{M_{x_{dyn}}} + \frac{M_y}{M_{y_{dyn}}} + \frac{M_z}{M_{z_{dyn}}} \leq 1$							
table values							
<b>No-load torque</b>							
Nm	1,2		1,5		1,8		
<b>Speed</b>							
(m/s) max	4		6		8		
<b>Tensile force</b>							
permanent (N)	900		1900		4000		
0,2 s (N)	1000		2090		4300		
<b>Geometrical moments of inertia of aluminium profile</b>							
I <sub>y</sub> mm <sup>4</sup>	6,6 x 10 <sup>5</sup>		22,2 x 10 <sup>5</sup>		57,2 x 10 <sup>5</sup>		
I <sub>z</sub> mm <sup>4</sup>	38,6 x 10 <sup>5</sup>		122,0 x 10 <sup>5</sup>		310 x 10 <sup>5</sup>		
Elastic modulus N/mm <sup>2</sup>	70000		70000		70000		

For life-time calculation of rollers use our homepage.

Driving torque:

$$M_o = \frac{F \cdot P \cdot S_i}{2000 \cdot \pi} + M_n$$

$$P_o = \frac{M_o \cdot n}{9550}$$

- F = force (N)
- P = pulley action perimeter (mm)
- S<sub>i</sub> = safety factor 1,2 ... 2
- M<sub>n</sub> = no-load torque (Nm)
- n = rpm pulley (min<sup>-1</sup>)
- M<sub>o</sub> = driving torque (Nm)
- P<sub>o</sub> = motor power (KW)

Deflection:

$$f = \frac{F \cdot L^3}{E \cdot I \cdot 192}$$

- f = deflection (mm)
- F = load (N)
- L = free length (mm)
- E = elastic modulus 70000 (N/mm<sup>2</sup>)
- I = second moment of area (mm<sup>4</sup>)

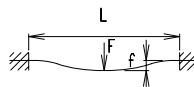

# Positioning system DLZPVI 120, 160, 200

Dimensions (mm)

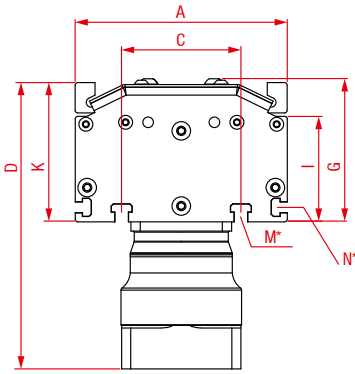

Optionally available with angular planetary gearbox

Increasing the carriage length will increase the basic length by the same amount.

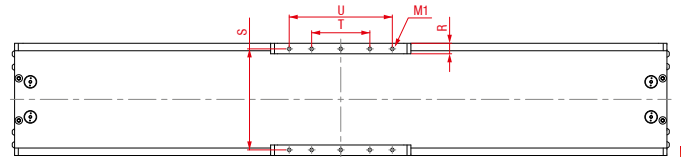
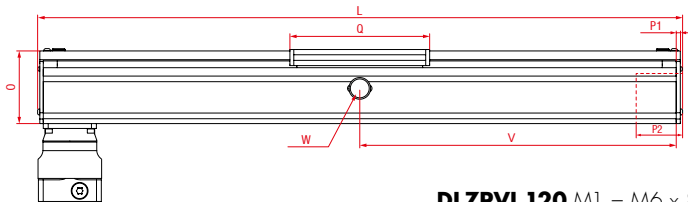

\*slide nuts

**DLZPVI 120** M1 = M6 x 8 only 8 threaded holes in the carriage  
**DLZPVI 160** M1 = M8 x 12 **DLZPVI 200** M1 = M10 x 12

V = Q + 100  
 W = servicing position

Size	Basic length L	A	C	D	G	I	K	M for	N for	O	P1	P2	Q	R	S	T	U	Basic weight without gearbox	Weight per 100 mm
DLZPVI 120	225	120	78	169	82,5	60	79	M6	M5	78	2	35	152	11,5	106	40	120	3,74 kg	0,65 kg
DLZPVI 160	285	160	90	217,5	108,5	80	106	M8	M6	104	3	52,5	196	15	144	80	160	10,42 kg	1,26 kg
DLZPVI 200	350	200	140	251	132,5	100	129	M10	M8	128	3	62,5	256	17	180	100	200	17,44 kg	2,18 kg

8.1

**0** Choice of guide body profile: *Stainless versions upon request.*

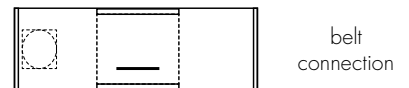
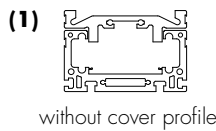
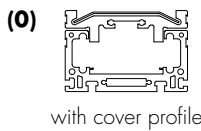

**0** Choice of carriages:

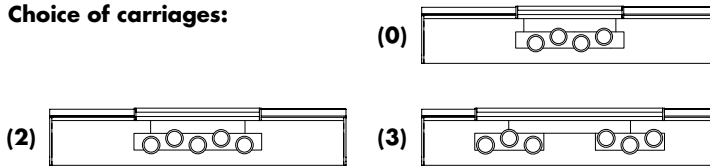

Size	Version 2		Version 3	
	Q	L	Q	L
120	192	265	232	305
160	246	335	296	385
200	320	420	400	500

**0** Drive version:

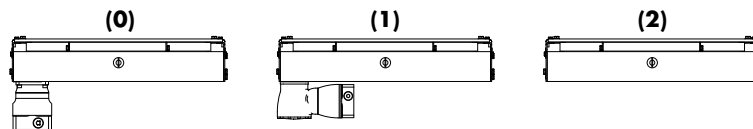

(0) planetary gearbox  
 (1) angular planetary gearbox  
 (2) without gearbox

**Belt table:**

Code-No.	Size	Belt	mm/rev.	Number of teeth
0 4	120	5M25	130	26
0 7	160	8M30	176	22
0 9	200	8M50	224	28

**Gearbox variants:**

Gearbox	DLZPVI 120	DLZPVI 160	DLZPVI 200
<b>Neugart</b> (0) (1)	PLN 70 WPLN 70	PLN 90 WPLN 90	PLN 115 WPLN 115
<b>SEW</b> (0)	PSKC 221	PSKC 321	PSKC 521
<b>Wittenstein</b> (0) (1)	SP+060 SK+060	SP+075 SK+075	SP+100 SK+100

**DLZPVI 160 1 0 0 0 0 7 1 01500** Basic length + stroke = total length  
 Pos. 1 2 3 4 5 6 7

Sample ordering code:  
 DLZPVI 160 with cover profile, standard carriage, with planetary gearbox, 1202 mm stroke.