

# Positioning system QSSZ 60, 80

## Belt drive

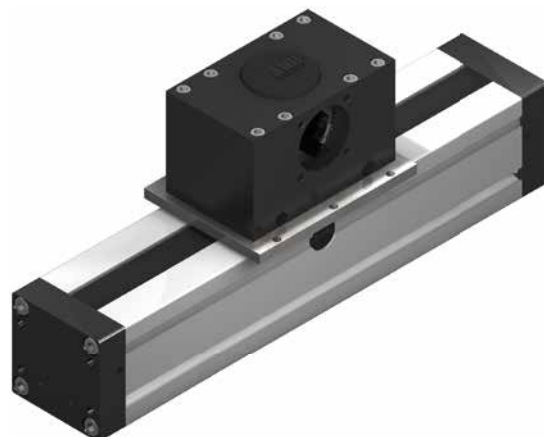
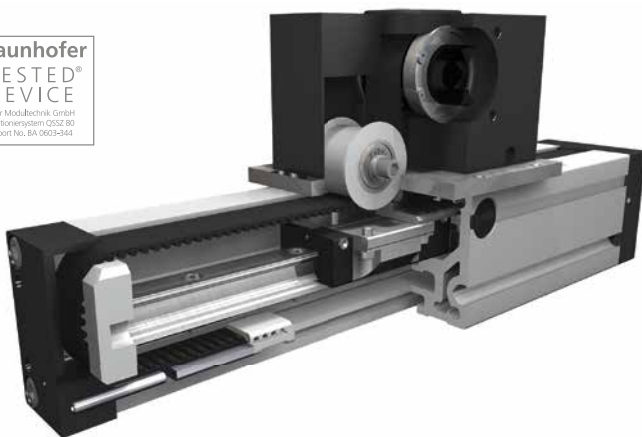

### Function:

This linear unit consists of a square aluminium profile with integrated rail guidance. The carriage, which has runner blocks, is driven by a timing belt. Each standard pulley includes a coupling claw on one side and is equipped with maintenance-free ball bearings. Belt tension can be readjusted by a simple screw adjustment device in the carriage. This device can also be used for symmetrical adjustment of two or more linear units running parallel.

### Fitting position:

As required. Max. length 3.000 mm without joints.

### Carriage mounting:

By T-slots.

### Unit mounting:

By T-slots and mounting sets. The linear axis can be combined with any T-slot profile.

### Belt performance:

HTD with steel reinforcement, no backlash when changing direction, repeatability  $\pm 0,1$  mm.

### Carriage support:

In the standard version, the carriage runs on 2 runner blocks which can be serviced at a central servicing position. For longer carriages the number of runner blocks can be increased.

### Forces and torques

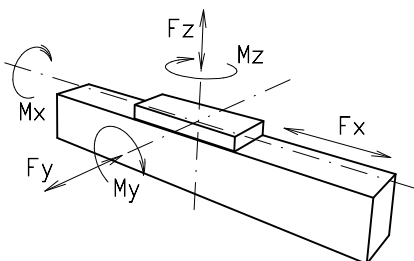

Size	60		80	
<b>permitted dyn. forces*</b>	5000 km	10000 km	5000 km	10000 km
$F_x$ (N)	97	87	223	200
$F_y$ (N)	350	240	890	630
$F_z$ (N)	880	625	2100	1500
$M_x$ (Nm)	8	6	26	18
$M_y$ (Nm)	26	18	77	55
$M_z$ (Nm)	25	17	74	52
<b>All forces and torques related to the following:</b>				
existing values $\frac{F_y}{F_{y_{dyn}}} + \frac{F_z}{F_{z_{dyn}}} + \frac{M_x}{M_{x_{dyn}}} + \frac{M_y}{M_{y_{dyn}}} + \frac{M_z}{M_{z_{dyn}}} \leq 1$				
table values $\frac{F_y}{F_{y_{dyn}}} + \frac{F_z}{F_{z_{dyn}}} + \frac{M_x}{M_{x_{dyn}}} + \frac{M_y}{M_{y_{dyn}}} + \frac{M_z}{M_{z_{dyn}}} \leq 1$				
<b>No-load torque</b>				
Nm		1,0	1,4	
<b>Speed</b>				
(m/s) max		3	3	
<b>Tensile force</b>				
permanent (N)		Lifetime calculation see the internet		
<b>Geometrical moments of inertia of aluminium profile</b>				
$I_x$ mm <sup>4</sup>		16,5x10 <sup>5</sup>		
$I_y$ mm <sup>4</sup>		18,7x10 <sup>5</sup>		
Elastic modulus N/mm <sup>2</sup>		70000		

For life-time calculation use our homepage.

\* referred to life-time

Driving torque:

$$M_o = \frac{F \cdot P \cdot S_i}{2000 \cdot \pi} + M_n$$

$$P_o = \frac{M_o \cdot n}{9550}$$

F = force (N)  
 P = pulley action perimeter (mm)  
 Si = safety factor 1,2 ... 2  
 Mn = no-load torque (Nm)  
 n = rpm pulley (min<sup>-1</sup>)  
 Mo = driving torque (Nm)  
 Po = motor power (KW)

Deflection:

$$f = \frac{F \cdot L^3}{E \cdot I \cdot 192}$$

f = deflection (mm)  
 F = load (N)  
 L = free length (mm)  
 E = elastic modulus 70000 (N/mm<sup>2</sup>)  
 I = second moment of area (mm<sup>4</sup>)

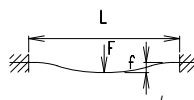

# Positioning system QSSZ 60, 80

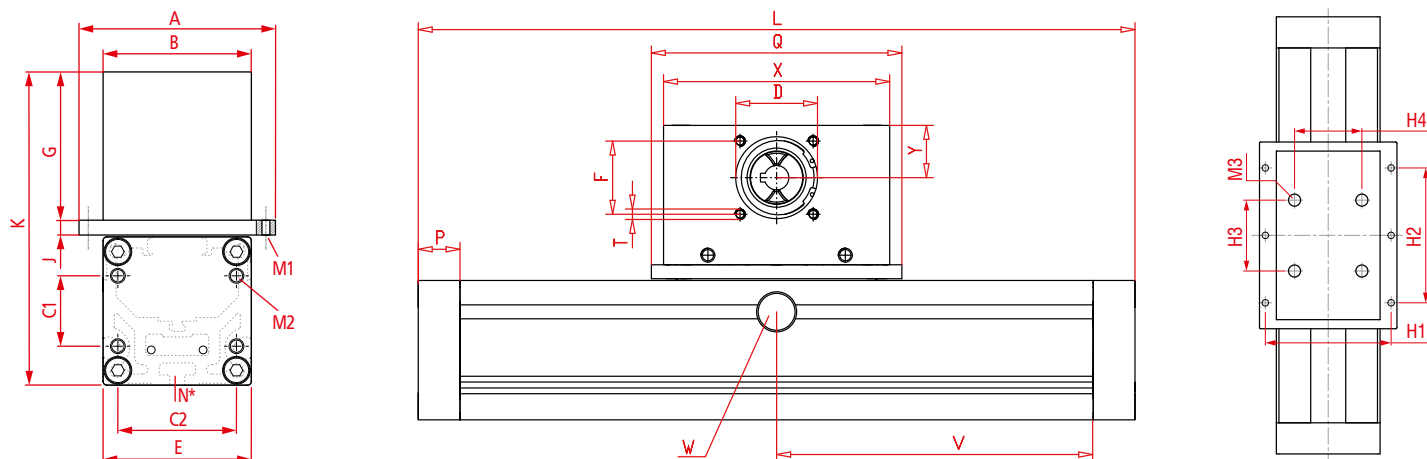

\*For slide nuts refer to chapter 2.2 page 2

$V = Q + 100 \text{ mm}$     $W = \text{servicing position}$

Size	Basic length L	A	B	C1	C2	D -0,05	E	F	G	J	K	N for	P	Q	T	X	Y	Basic weight	Weight per 100 mm
QSSZ 60	168	60	60	28	48	37	60	32	65	7,50	134,5	M 5	20	124	M 5	110	20	3,30 kg	0,47 kg
QSSZ 80	200	106	80	38	62	47	80	42	80	8	169	M 6	24	144	M 6	130	30	5,90 kg	1,02 kg

7.1

- 0 Choice of guide body profile:**  
**(0)** Standard **(1)** corrosion-protected screws  
**(4)** expanded corrosion-protected version  
 (depending on the availability of components)

Size	H1	H2	H3	H4	M1	M2	M3
QSSZ 60	-	-	60	45	-	M6	M8
QSSZ 80	97	104	-	-	M6	M8	-

- 0 Choice of carriages:**

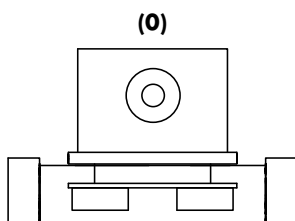

- 0 Drive version:**

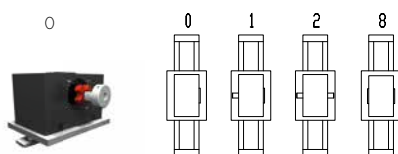

Size	Shaft ø h6 x length	Key
60	10 x 27	3x3x25
80	14 x 35	5x5x28

8 is as 0, but with coupling claws on both sides. The standard version is supplied without shaft. A shaft can be retrofitted by inserting it into the pulley bore and securing it with 2 locking rings.

**Belt table / Coupling claw**

Code No.	Size	Belt	Pulley		Coupling
			mm/rev.	Number of teeth	
0 3	60	5M15	100	20	9
0 7	80	5M25	130	26	14

Basic length + stroke = total length

For additional accessories refer to chapter 2.2 – 3.2

QSSZ 80 1 0 0 0 0 7 1 01500

Pos. 1 2 3 4 5 6 7

Sample ordering code:

QSSZ80, standard body profile, standard carriage, coupling claw on one side, 1300 mm stroke

