

Positioning system ELZU 30, 40, 60, 60S, 80, 80S, 100

Surface portal

Specifications

3.1

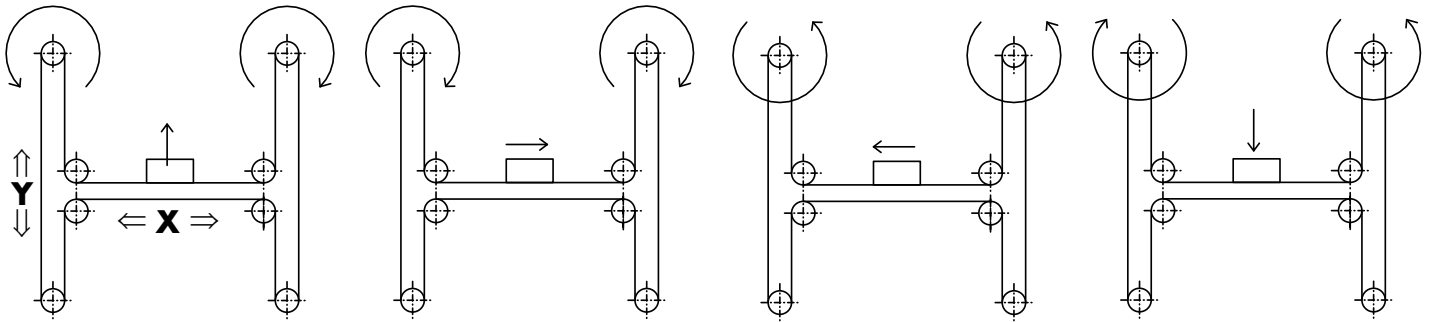

Function:

Surface portal, consisting of 2 Y-axes and 1 X-axis, driven by one rotating belt. This belt runs around different deflection pulleys. Positioning is achieved by two motors. The coordinate is diagonal to the deflection points of the Y-axis.
 Advantage: Only small weights are moved, thus enabling high accelerations to be achieved.

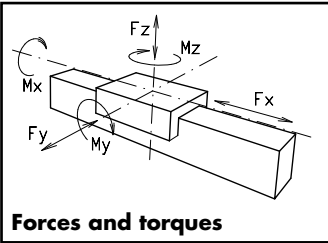

Forces and torques

- Fitting position:** As required. Max. length and width 3.000 mm.
- Carriage mounting:** By T-slots.
- Unit mounting:** By T-slots or tapped holes in the bearing block, mounting sets.
- Belt type:** HTD with steel reinforcement, no backlash when changing direction, repeatability: ± 0,1 mm.

As required. Max. length and width 3.000 mm.
 By T-slots.
 By T-slots or tapped holes in the bearing block, mounting sets.
 HTD with steel reinforcement, no backlash when changing direction, repeatability: ± 0,1 mm.

Size	ELZU 30		ELZU 40		ELZU 60		ELZU 60 S		ELZU 80		ELZU 80 S		ELZU 100	
	static	dynamic	static	dynamic	static	dynamic	static	dynamic	static	dynamic	static	dynamic	static	dynamic
Forces/Torques														
F_x (N)	200	180	390	350	894	800	894	800	1900	1800	1900	1800	4000	3800
F_y (N)	90	60	1200	700	3000	2000	4100	3100	3000	2000	4600	3600	8000	6500
F_z (N)	90	60	900	650	1700	1100	2160	1600	1700	1100	3000	1800	3600	2200
M_x (Nm)	10	5	25	20	67	43	88	65	90	55	170	140	300	230
M_y (Nm)	13	6	32	18	90	70	190	140	110	80	270	230	400	270
M_z (Nm)	14	7	35	25	120	100	230	170	150	120	300	220	750	500
All forces and torques relate to the following:														
existing values $\frac{F_y}{F_{y_{dyn}}} + \frac{F_z}{F_{z_{dyn}}} + \frac{M_x}{M_{x_{dyn}}} + \frac{M_y}{M_{y_{dyn}}} + \frac{M_z}{M_{z_{dyn}}} \leq 1$														
No-load torque														
Nm	0,2		0,6		1,2		1,2		1,8		1,8		2,6	
Speed														
(m/s) max	2		4		5		5		6		6		8	
Tensile force														
permanent (N)	200		390		900		900		1900		1900		3600	
0,2 s (N)	280		480		1000		1000		2090		2090		4000	
Geometrical moments of inertia of aluminium profile														
I_x mm ⁴	4,09x10 ⁴		1,32x10 ⁵		6,79x10 ⁵		6,79x10 ⁵		18,99x10 ⁵		18,99x10 ⁵		44,4x10 ⁵	
I_y mm ⁴	4,00x10 ⁴		1,34x10 ⁵		6,97x10 ⁵		6,97x10 ⁵		18,97x10 ⁵		18,97x10 ⁵		44,8x10 ⁵	
E-Modulus N/mm ²	70000		70000		70000		70000		70000		70000		70000	

For life-time calculation of rollers use our homepage.

Driving torque:

$$M_o = \frac{F \cdot P \cdot S_i}{2000 \cdot \pi} + M_n$$

$$P_o = \frac{M_o \cdot n}{9550}$$

- F = force (N)
- P = pulley action perimeter (mm)
- S_i = safety factor 1,2 ... 2
- M_n = no-load torque (Nm)
- n = rpm pulley (min⁻¹)
- M_o = driving torque (Nm)
- P_o = motor power (KW)

Deflection:

$$f = \frac{F \cdot L^3}{E \cdot I \cdot 192}$$

- f = deflection (mm)
- F = load (N)
- L = free length (mm)
- E = elastic modulus 70000 (N/mm²)
- I = second moment of area (mm⁴)

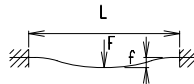

Positioning system ELZU 30, 40, 60, 60S, 80, 80S, 100

Dimensions (mm)

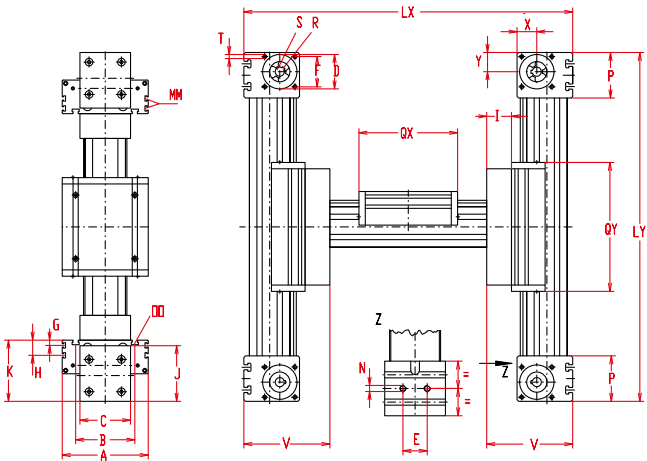

3.1

*For slide nuts refer to chapter 2.2 page 2

Size	Basic length		A	B	C	D -0,05	E	F	G	H	I	J	K	MM for	N for	OO for	P	Qx	Qy	T	V	X	Y	Basic weight	Weight per 100 mm
	Lx	Ly																							
ELZU 30	240	210	70	56	42	28	13	25	-	-	27	44	47	-	M 5	M 6	36	82	126	M 5	74	16	16	6,3 kg	0,13 kg
ELZU 40	304	250	100	66	58	37	18	32	-	-	26	58	64	-	M 6	M 6	49	122	147	M 5	90	20,5	20,5	6,8 kg	0,24 kg
ELZU 60	426	330	144	96	80	47	30	42	-	-	33	82	90	-	M 8	M 8	59	168	210	M 6	123	27	26	14,7 kg	0,62 kg
ELZU 60S	450	330	170	108	80	47	30	42	-	-	33	82	94	-	M 8	M 8	59	194	210	M 6	127	27	26	17,7 kg	0,62 kg
ELZU 80	535	435	170	117	100	68	40	60	10,5	30,5	44	110	121	M 6	M10	M10	90	194	244	M 8	165	39	38	31,0 kg	1,00 kg
ELZU 80S	555	455	190	126	100	68	40	60	12,5	30	44	110	122	M6	M10	M 8	90	214	264	M 8	166	39	38	32,0 kg	1,00 kg
ELZU 100	758	590	230	155	130	90	50	80	-	29	69	135	154	M10	M12	M10	110	300	360	M10	223	50	50	47,3 kg	1,40 kg

0 Choice of guide body profile:

- (0) Standard
- (2) corrosion-protected guide rods and screws
- (4) expanded corrosion-protected version (depending on the availability of components)

0 Choice of carriages:

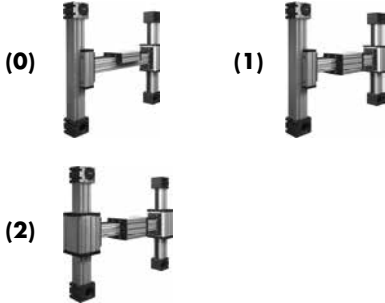

Size	Version 1				Version 2			
	Qx	Lx	Qy	Ly	Qx	Lx	Qy	Ly
30	94	252	126	210	94	252	138	222
40	138	320	147	250	138	320	163	266
60	184	442	210	330	184	442	226	346
60S	214	468	210	330	214	468	230	350
80	210	551	244	435	210	551	260	451
80S	234	575	264	455	234	575	284	475
100	316	774	360	590	316	774	376	606

0 Drive version:

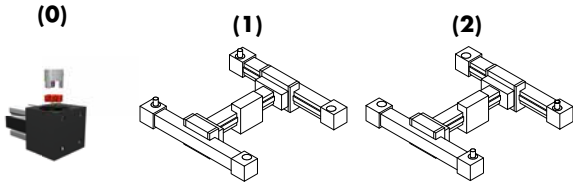

The standard version is supplied without shaft. A shaft can be retrofitted by inserting it into the pulley bore and securing it with 2 locking rings.

Belt table

Code No.	Size	Belt	mm/rev.	Number of teeth
0 1	30	3M12	75	25
0 3	40	5M15	100	20
0 4	60 (S)	5M25	130	26
0 7	80 (S)	8M30	192	24
0 9	100	8M50	256	32

Shaft dimensions / Coupling claw

Size	Shaft ø h6 x length	Key	Coupling
30	6 x 15	2x2x12	7
40	10 x 27	3x3x25	9
60 (S)	14 x 35	5x5x28	14
80 (S)	18 x 45	6x6x40	19
100	22 x 45	6x6x40	24

X-Axis Basic length + stroke = total length

Y-Axes Basic length + stroke = total length

ELZU 60 7 0 0 0 0 4 1 01500

ELZU 60 8 0 0 0 0 4 1 00700

For combination kits and connecting elements refer to chapter 2.2

Sample ordering code:

ELZU 60 with standard body profile, standard carriage, coupling claw on one side, stroke X = 1074 / Y = 370 mm

Pos. 1 2 3 4 5 6 7

