

GFX

HEPCO GUIDANCE SYSTEM FOR BECKHOFF XTS

Contents

Hepco Guidance Systems for Beckhoff XTS

Introduction	1
GFX 1-Trak and GFX 1-Trak Lite System Composition	2
GFX PRT2 System Composition	3
Mover Options	4
Defining System Requirements	4
Bleed Lubrication	4
Application Examples	5

Technical Data

GFX 1-Trak and GFX 1-Trak Lite Systems	7
GFX PRT2 Systems	8

Ordering Details

System and Component Specification	9
------------------------------------------	---

Introduction

HepcoMotion Guidance System For Beckhoff XTS Systems

Linear motion experts HepcoMotion have worked with Beckhoff to develop specialised versions of the PRT2 and 1-Trak guidance systems to work with the Beckhoff XTS eXtended Transport System. This option meets the needs of higher duty XTS applications where motion profiles and long term durability requirements are particularly demanding.

The Beckhoff XTS eXtended Transport System uses linear motor technology to drive independently controlled movers around a track. This provides a solution for complex, high speed motion profiles up to 4m/s, without compromising positional accuracy.

The system integrates Hepco's patented 1-Trak guidance system and lightweight three bearing mover, providing the optimum mover path for Beckhoff's 180° motor modules. 1-Trak systems consist of a solid steel base plate with 1-Trak end segments and custom ground straight slides attached, providing rigidity and the highest level of accuracy and precision.

Hepco's PRT2 systems are compatible with motor module segment sizes 22.5° and 45°, offering solutions for larger applications. Based on Hepco's standard PRT2 range, track solutions can be configured into circular, oval and rectangular systems as standard, and can be supplied as complete factory assembled systems, semi-assembled track systems or components.

Stainless steel versions are available for all track solutions and can be adapted to suit customers' needs. Please contact Hepco for more information on specialist requirements.

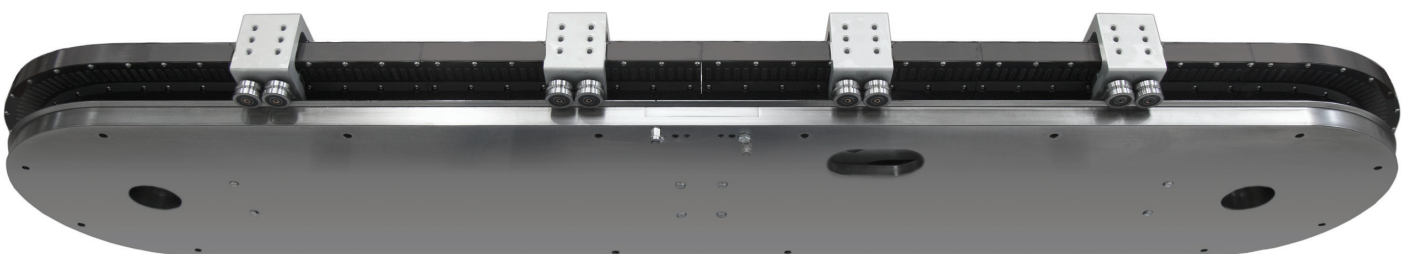

Features and Benefits

- Hardened V guidance maintains accuracy over long periods
- Low maintenance bleed lubrication system
- All systems available in stainless steel
- Available with food compatible grease
- Lightweight mover
- High rigidity
- Removable track section for easy maintenance

GFX 1-Trak and GFX 1-Trak Lite System Composition

HepcoMotion's GFX 1-Trak systems include a patented curved track form, providing the optimum mover path for 180° motor modules. There are two options available:

1-Trak Systems

GFX 1-Trak systems are supplied with an integral base and motor-mounting structure. These systems are limited to a maximum length of 10 straight motor modules (2.5m).



1-Trak Lite Systems

GFX 1-Trak Lite is a spacer slide version of Hepco's 1-Trak guidance system. It can be provided as a kit of components for mounting on a custom back plate, or as a complete assembly. Its length is only limited by the number of motors and movers supported by a Beckhoff control system. Please see page 7 or contact Beckhoff for information on these limitations.



Both 1-Trak and 1-Trak Lite systems use the same three bearing mover design.

Movers are available in various bearing and length combinations, providing a range of load, moment and acceleration capacities.

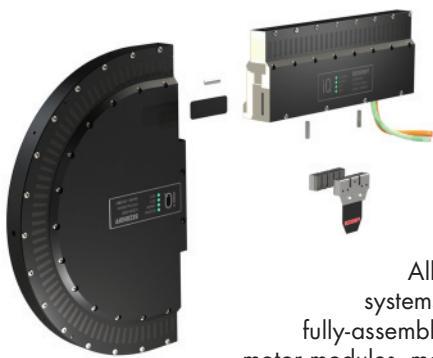

All Hepco guidance systems can be supplied fully-assembled, with Beckhoff motor modules, mover magnets and mover encoder flags, partially assembled, or as a kit of components (see note 1 and 2).

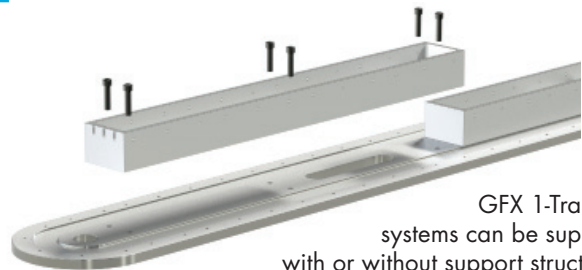

GFX 1-Trak Lite systems can be supplied with or without support structures.

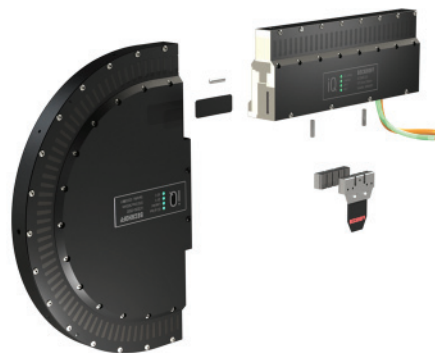

Notes:

1. Please check motor compatibility. If you wish to re-use motors predating 2016, please contact Hepco's technical department.
2. Customers are expected to purchase XTS components separately from Beckhoff.

GFX PRT2 System Composition

PRT2 Ring and Track Systems



GFX PRT2 track systems can be configured into oval or rectangular systems.

PRT2 Ring Systems



GFX PRT2 ring and track systems use four bearing fixed centre movers. Please see the PRT2 catalogue for more information on fixed centre carriages.

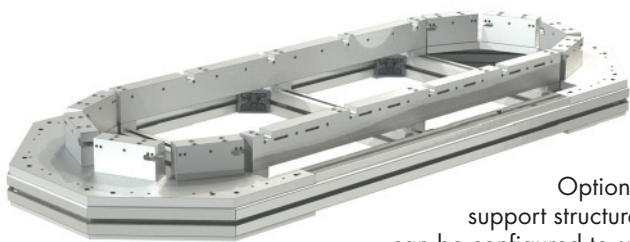
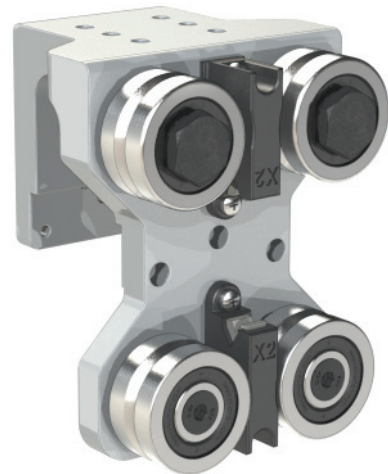
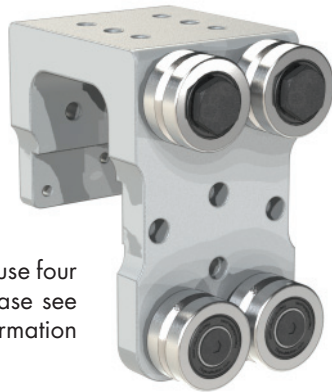

Optional support structures can be configured to suit customer requirements.

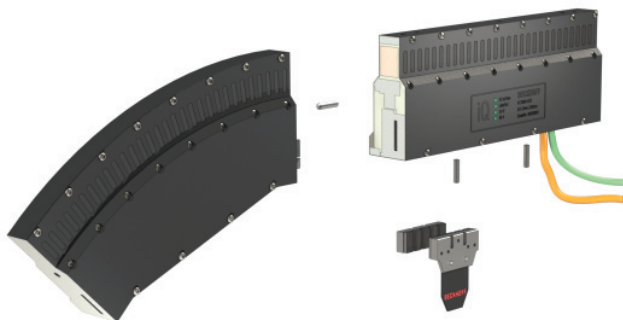

All Hepco guidance systems can be supplied fully assembled, with Beckhoff motor modules, mover magnets and mover encoder flags, partially assembled, or as a kit of components. Customers should provide their own Beckhoff components for assembly at Hepco. Please check motor compatibility. If you wish to re-use motors predating 2016, please contact Hepco's technical department.

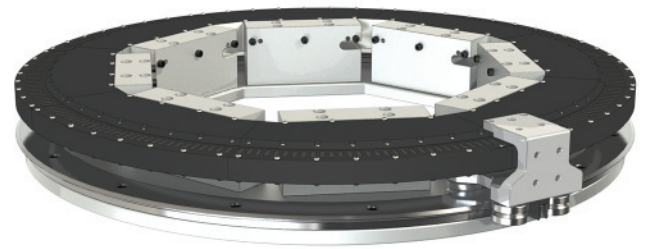
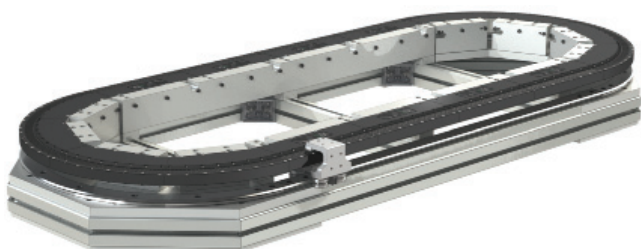

Additional Information

Mover Options

Below is a list of the key parameters and how they vary with mover size and bearing type:

Three bearing 1-Trak Mover

- 25mm outer bearings
- Most compact mover
- Lowest mover mass
- Suitable for light moment loads
- Available in standard lengths: 52mm and 72mm

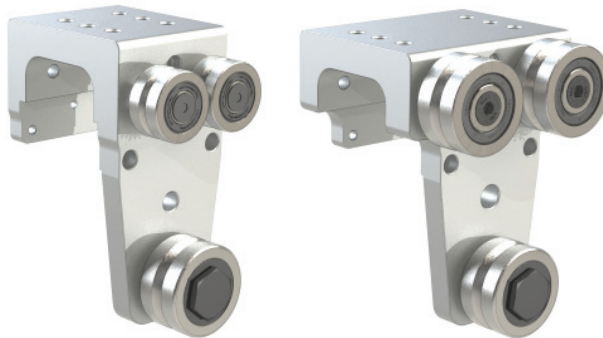

- 34mm outer bearings
- Compact mover
- Low mover mass
- Suitable for medium moment loads
- Available in standard lengths: 70mm and 80mm

Four bearing PRT2 Mover

- All 25mm bearings
- Compact high moment mover
- Low mover mass
- Suitable for medium moment loads
- 55mm long as standard

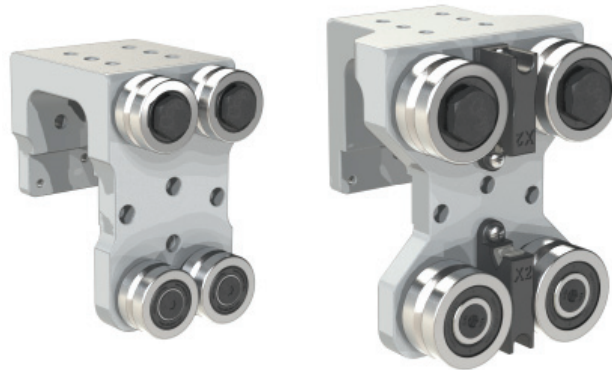

- All 34mm bearings
- Longer bearing life
- Lubricator option
- Suitable for heavier moment loads
- 85mm long as standard

Defining System Requirements

When specifying a HepcoMotion guidance system for Beckhoff XTS, the following factors are considered:

- Payload, fixture mass and position relative to mover
- Speed and acceleration profile of the application
- Duty cycle
- Precision requirement
- Required system life
- Machine size - system length
- Orientation
- Additional process loads
- Servicing and maintenance requirements
- Required mover pitch
- Environmental conditions (temperature, humidity, pollutants, variation etc.)

Bleed Lubrication

Sufficient lubrication is essential for all Hepco guidance systems for Beckhoff XTS. All systems incorporate a bleed lubrication facility, which channels lubricant directly to the vee faces of the slide.

Lubricant is then distributed around the system by the movers. This process can be aided with lubricators mounted on movers (PRT2 systems only).

It is highly recommended that lubrication ports are situated approximately once every 3 metres of track. For more information on lubrication requirements, flow rates and food grade lubricants, please see the Hepco Guidance Systems for Beckhoff XTS - Lubrication Datasheet 01.

Please see the PRT2 catalogue page 52 for more information on bleed lubrication and positioning lubrication ports on a PRT2 track system.



Application Examples - Features and Benefits

High Speed Lane Divider

This example shows a vertically mounted, lightly loaded, high speed and high duty GFX 1-Trak system being used to sort randomly positioned items into two separate lanes.

- High rigidity - solid steel base plate
- Positional repeatability
- Durable - hardened guidance system
- Low maintenance - integrated bleed lubrication
- Standard configuration

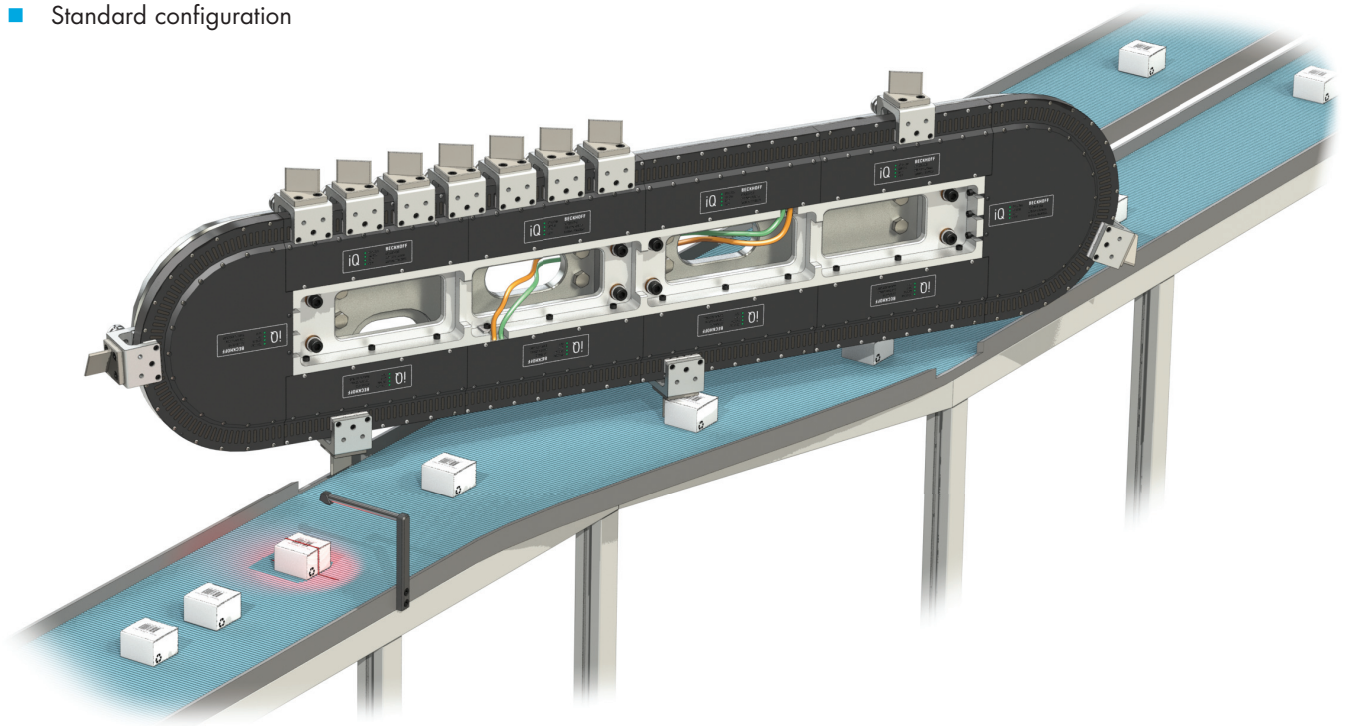

Double Sided System

Two GFX 1-Trak systems manufactured with a single 'back to back' base provide a compact and accurate assembly.

- High rigidity - solid steel back plate
- Excellent parallelism - ground back plate
- Positional accuracy
- Compact
- Customisable - designed to suit a specific application

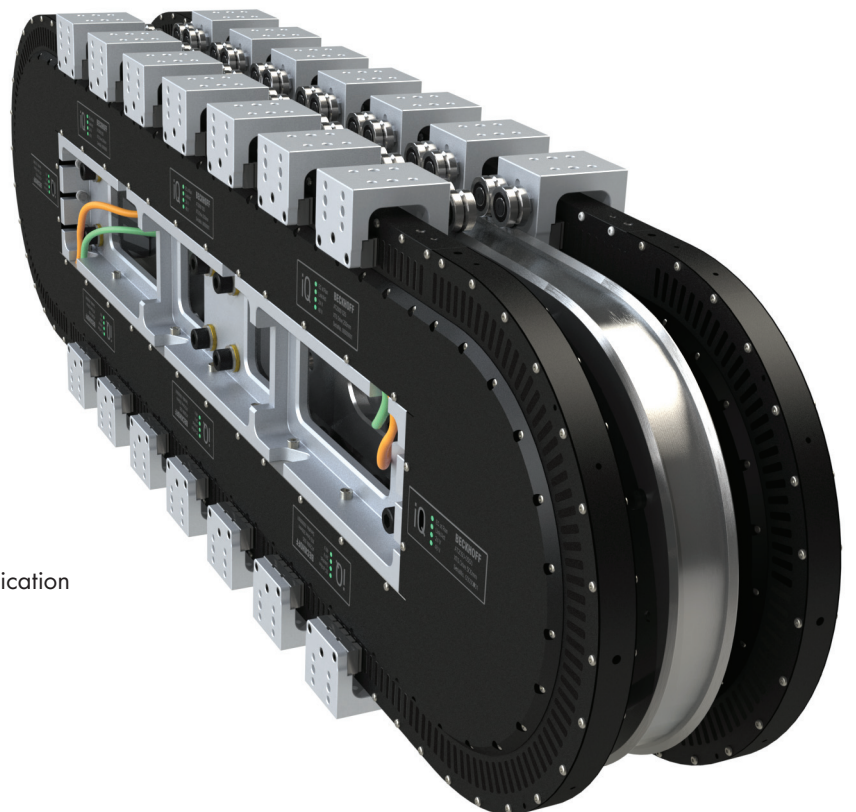

Application Examples - Features and Benefits

Multi-Operation and Variable Speed Application

The horizontally mounted system shown below comprises of a GFX PRT2 track system mounted on a customisable Hepco MCS support structure.

- Durability - hardened guidance system
- High moment capacity - for higher process forces
- Low maintenance - integrated bleed lubrication
- Machine integration - Hepco MCS support structure
- Precision ring and track technology (PRT2)
- Standard configuration

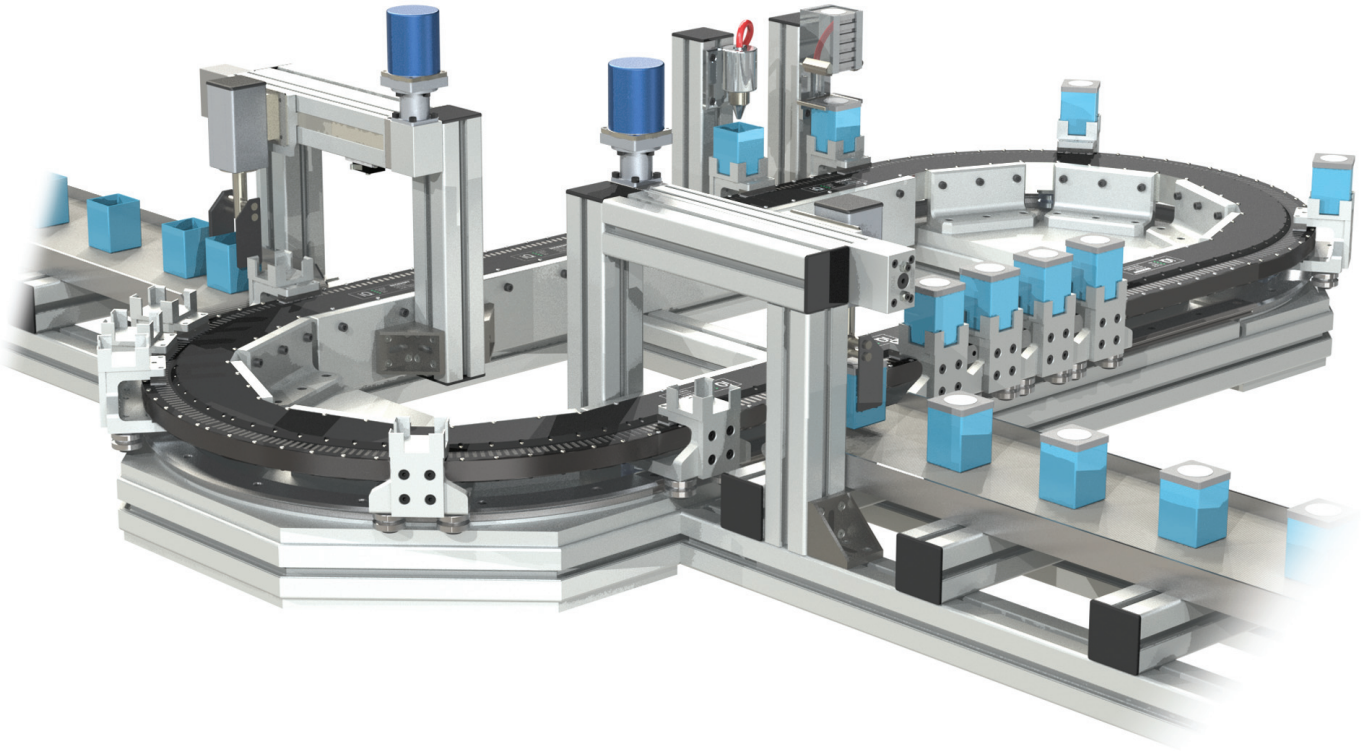

Multidirectional Bend

This high temperature assembly application utilises 180° end modules, plus internal and external 22.5° curved Beckhoff modules, creating an 'S' bend system layout, with a GFX 1-Trak Lite track system.

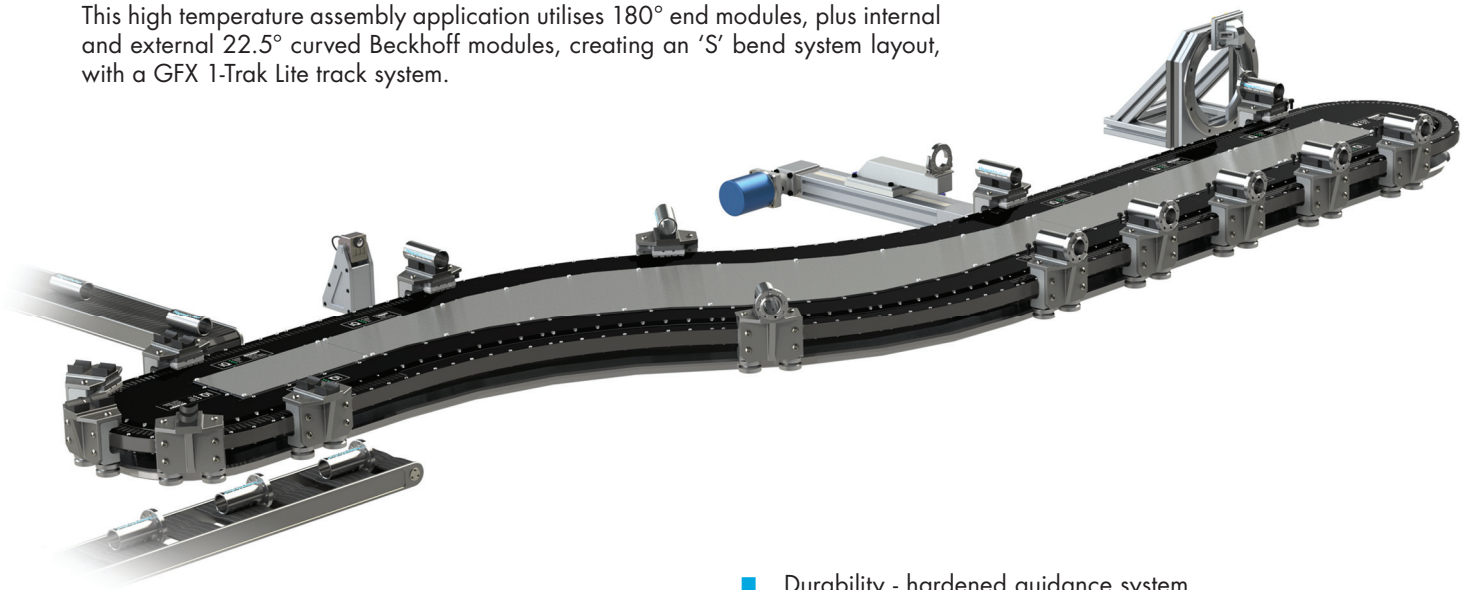

- Special mover designed to overcome temperature variation.
- Low maintenance - integrated bleed lubrication
- High load capacity
- Durability - hardened guidance system
- Harsh environment - Vee system technology
- Positional repeatability
- High load capacity
- Flexible layout - patented track geometry
- Customisable - designed to suit a specific application

Technical Data - GFX 1-Trak and 1-Trak Lite Systems

The GFX 1-Trak guidance system is supplied with an integral base and motor mounting structure. The system has a solid steel or stainless steel back plate with 1-Trak end segments and ground GV3 or SL2 flat slide. The 1-Trak Lite systems are supplied as a set of components, with or without a support structure. Both system types share common geometry as shown below.

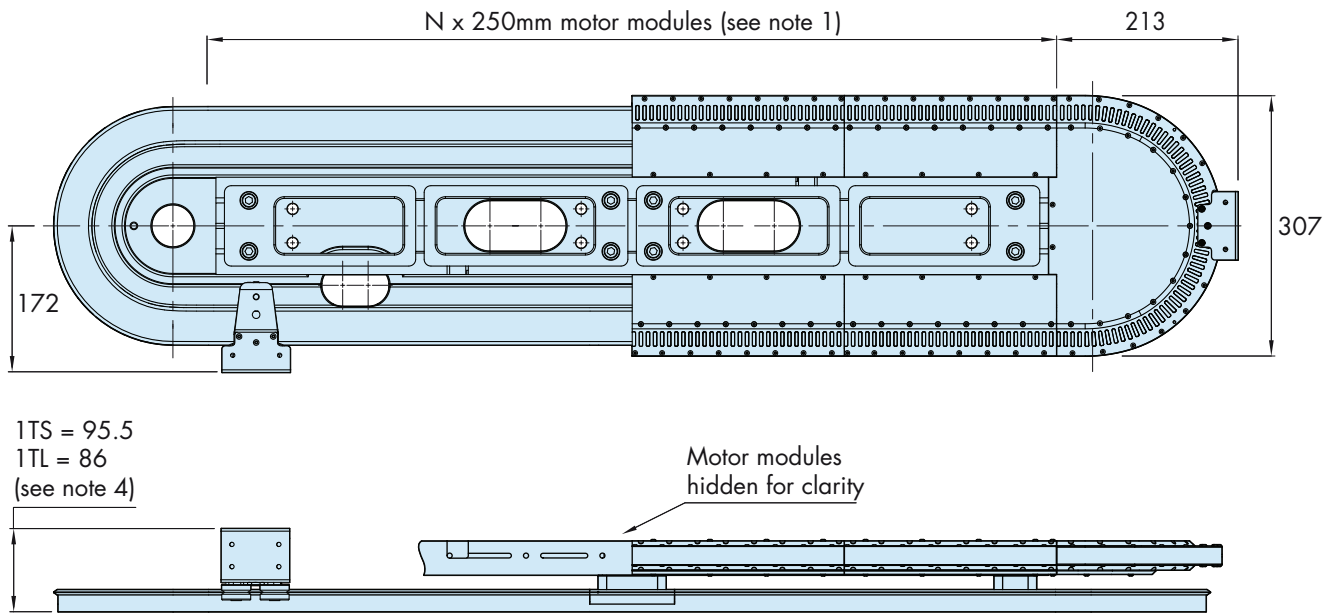

	Mover Part Number			
	GFX-1TC-C25	GFX-1TC-S25	GFX-1TC-C34	GFX-1TC-M34
L	52	72	70	80
A	26	45	45	55
Outer Bearing Diameter	25	25	34	34
Typical Payload*2	0.5kg - 5kg			
Mass*3	610g	680g	790g	820g

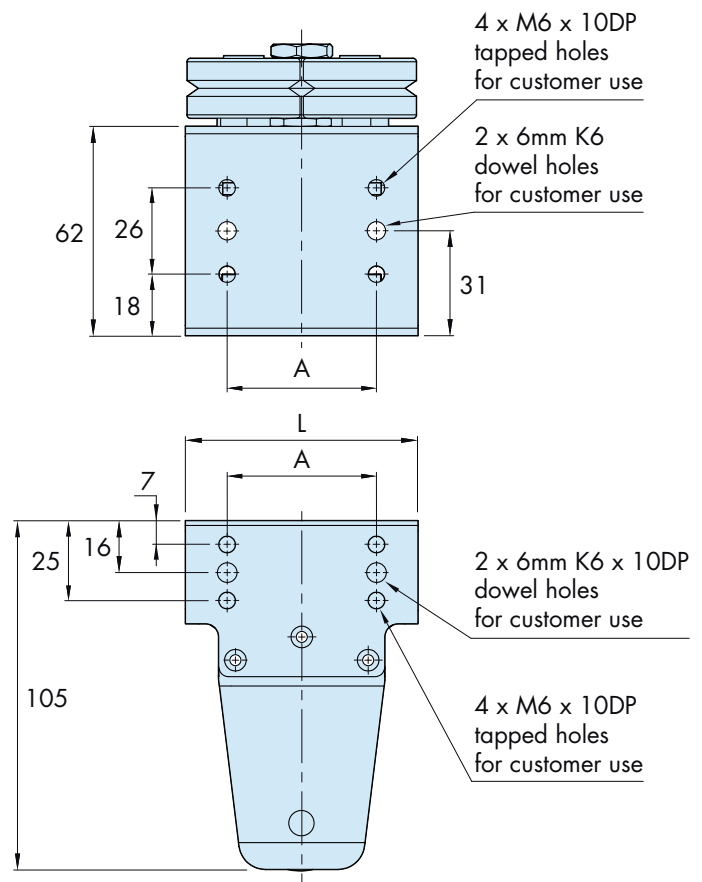

Notes:

1. GFX 1-Trak systems are limited to 10 motor modules (2.5m straight length). GFX 1-Trak Lite is restricted to the capacity of the Beckhoff motor control system which is at least 50 metres of total track length and 100 movers.
2. Please contact Hepco's technical department for more information on mover load and moment capacity.
3. Mass of movers includes Beckhoff magnet and encoder flag assembly.
4. See page 9 for system designations.

Technical Data - GFX PRT2 Systems

Guidance systems for Beckhoff XTS can also be supplied as PRT2 ring and track assemblies, which can be configured into oval, rectangular and circular systems. Motor modules are supplied in 45° or 22.5° segments. PRT2 systems require a four bearing fixed centre carriage (FCC) mover.

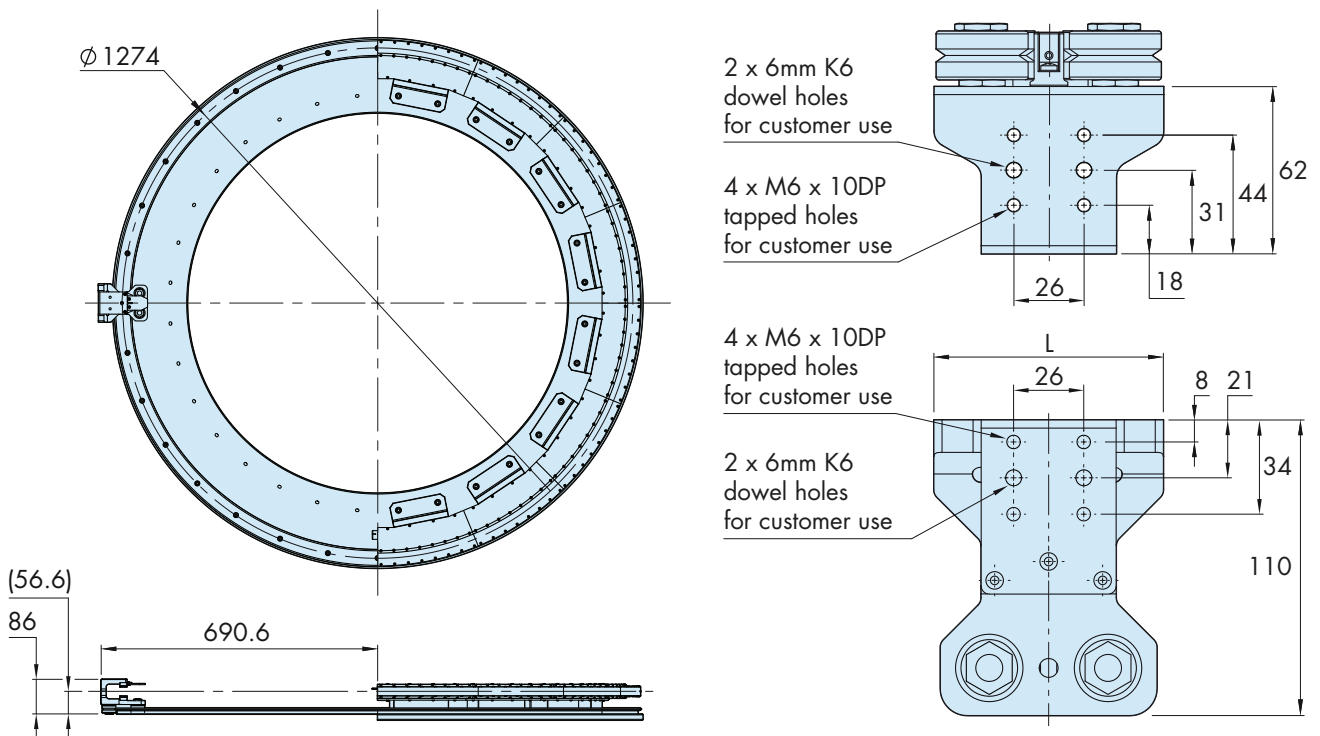
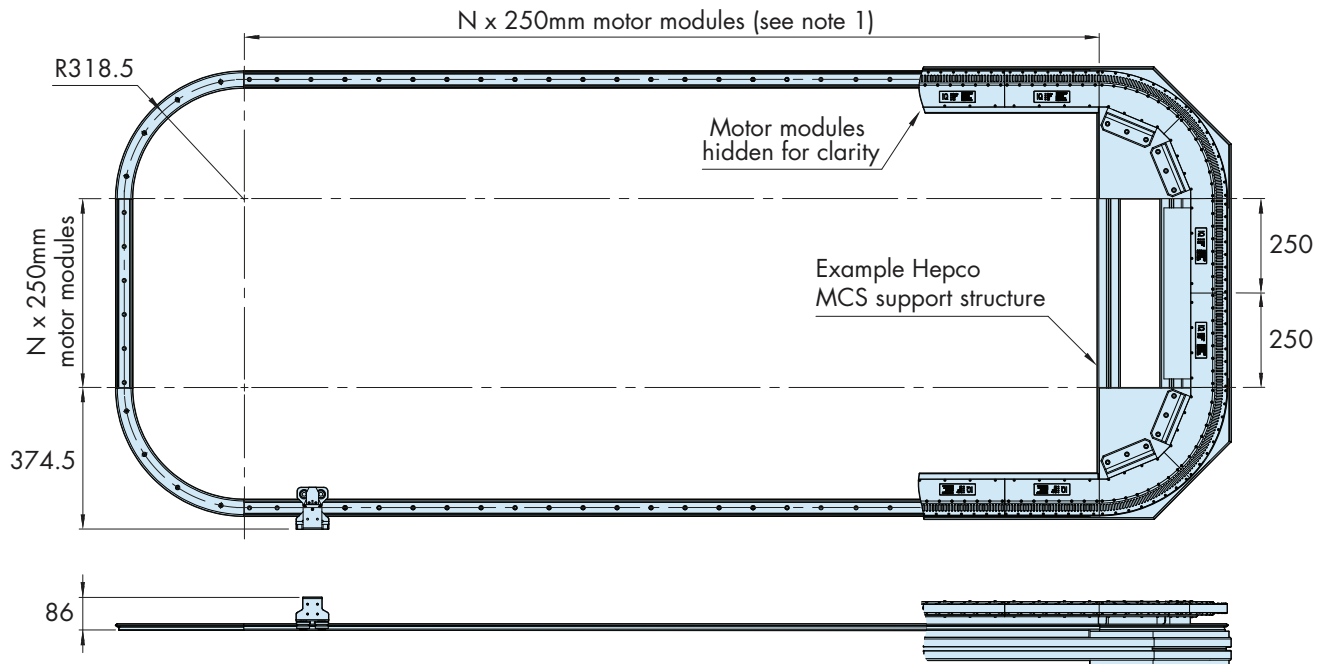

Mover Part Number	L	Bearing Diameter	Typical Payload*2	Mass*3
GFX-FCC-C25	55	25	0.5kg - 5kg	600g
GFX-FCC-M34	85	34	0.5kg - 5kg	950g

Notes:

- GFX PRT2 system length is restricted to the capacity of the Beckhoff motor control system, which is in excess of 50 metres of total track length and 100 movers.
- Please contact Hepco's technical department for more information on mover load and moment capacity.
- Mass of movers includes Beckhoff magnet and encoder flag assembly.

System and Component Specification - GFX 1-Trak Systems

GFX 1-Trak Systems

Corrosion resistant systems use all stainless steel track components.

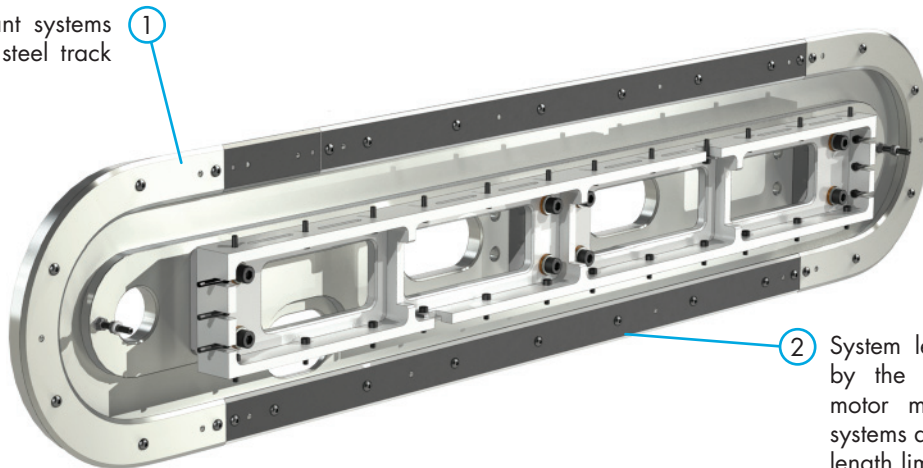

System length is determined by the number of straight motor modules. 1-Trak Lite systems do not have the same length limitations as standard 1-Trak systems (see page 2).

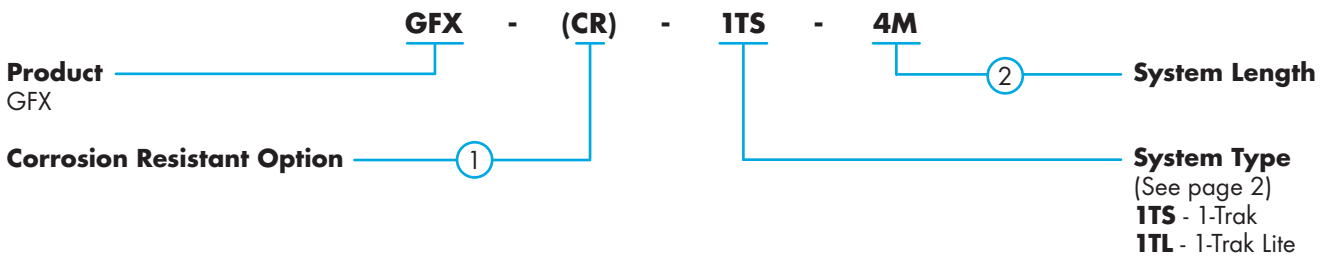

Movers

Corrosion resistant movers are supplied with stainless steel bearings.

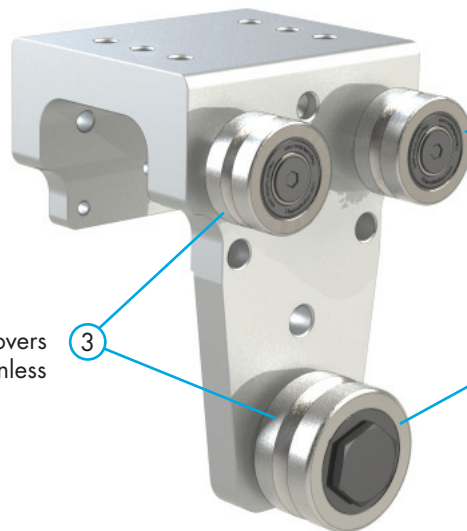

Outer bearing size also determines the size of the mover. Please see page 7 or the GFX Technical Guide for more mover information.

Outer bearings are double row as standard. **-DR** movers also incorporate double row inner bearings. Please see the GFX Technical Guide for mover load information.

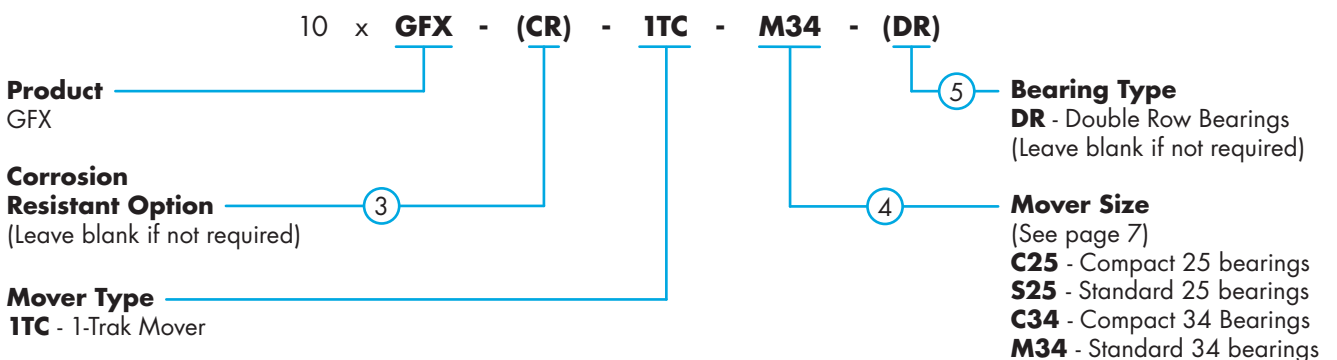

System and Component Specification - GFX PRT2 Systems

GFX PRT2 Track Systems

Corrosion resistant systems use all stainless steel track components.

Optional support structure shown. Contact Hepco's Technical Sales Department for more information.

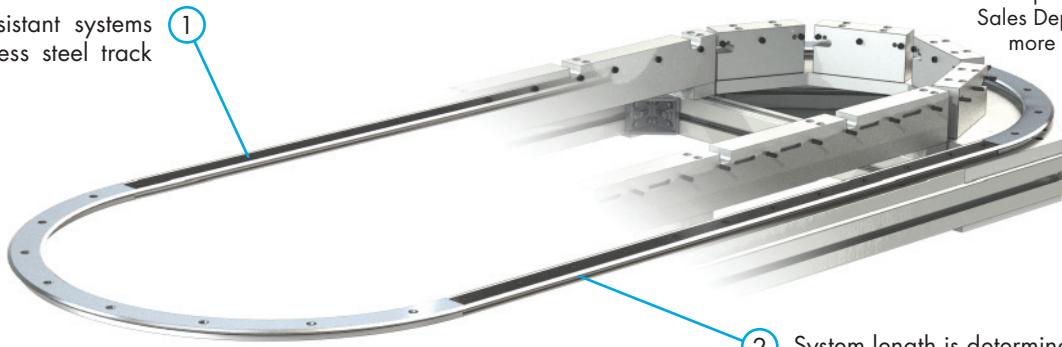

2 System length is determined by the number of straight motor modules.

Product GFX - (CR) - 637 - OVAL-4M
 GFX

Corrosion Resistant Option (Leave blank if not required) 1

System Size (See page 8)
OVAL-4M - (Oval)
4MX2M - (Rectangular)
RING-8M - (360° Ring*1)

Segment Diameter
637 - 45° Modules
1274 - 22.5° Modules*1

Movers

Corrosion resistant movers are supplied with stainless steel bearings.

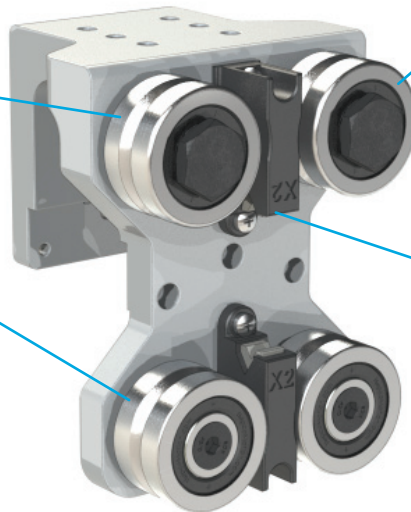

4 Outer bearing size also determines the size of the mover. Please see page 8 or the GFX Technical Guide for more mover information.

Inner concentric bearings are double row as standard. **-DR** movers also incorporate double row outer bearings. Please see the GFX Technical Guide for mover load information.

6 Fixed centre movers (FCC) can be supplied with slide lubricators.

20 x GFX - (CR) - FCC - 637 - M34 - (DR) - (LB)

Product GFX
 GFX

Corrosion Resistant Option (Leave blank if not required) 3

Mover Type FCC - Fixed centre (PRT2)

Segment Diameter
637 - 45° modules
1274 - 22.5° modules

Additional Options 6
LB - Slide lubricators
 (Leave blank if not required)

Bearing Type 5
DR - Double Row Bearings
 (Leave blank if not required)

Mover Size 4
 (See page 8)
C25 - Compact 25 bearings
M34 - Standard 34 bearings

Notes

- 360° GFX ring systems using 22.5° motor modules and 1274mm diameter rings require 16 motor modules.
- All movers are supplied fully assembled and adjusted to a system, unless requested otherwise.

HepcoMotion®
Lower Moor Business Park
Tiverton Way, Tiverton
Devon, England, EX16 6TG

Tel: +44 (0)1884 257000
Fax: +44 (0)1884 243500
E-mail: sales@hepcotion.com

CATALOGUE No. GFX Hepco Guidance System for Beckhoff XTS 02 UK © 2018 Hepco Slide Systems Ltd.

Reproduction in whole or part without prior authorisation from Hepco is prohibited. Although every effort has been made to ensure the accuracy of the information in this catalogue, Hepco cannot accept liability for any omissions or errors. Hepco reserves the right to make alterations to the product resulting from technical developments.

Many Hepco products are protected by: Patents, Copyright, Design Right or Registered Design. Infringement is strictly prohibited and may be challenged in law. The Customer's attention is drawn to the following clause in Hepco's conditions of sale:

'It shall be the Customer's sole responsibility to ensure that goods supplied by Hepco will be suitable or fit for any particular application or purpose of the Customer, whether or not such application or purpose is known to Hepco. The Customer will be solely responsible for any errors in, or omissions from, any specifications or information the Customer provides. Hepco will not be obliged to verify whether any such specifications or information are correct or sufficient for any application or purpose.'

Hepco's full conditions of sale are available on request and will apply to all quotations and contracts for the supply of items detailed in this catalogue.

HepcoMotion is the trading name of Hepco Slide Systems Ltd.