

CR/TH

FREELY PROGRAMMABLE ROTARY TABLES | CR/TH HEAVY DUTY ROTARY TABLE



CR/TH HEAVY DUTY ROTARY TABLE: MAKES LIGHT WORK OF HEAVY LOADS

FOR HORIZONTAL AXES

User-programmable rotary barrel drive of the TH range for horizontal loads and high breakdown torque levels. With screw-on surfaces for Buhl pinning and optional rotary encoder.

FREELY AND INTUITIVELY PROGRAMMABLE

W.A.S. 2 – WEISS Application Software: secure and fast commissioning with free-of-charge user software.

THE TECHNOLOGY MAKES THE DIFFERENCE

The cam drive, positioned far toward the outside, enables the highest precision and dynamic performance.



This cooling carousel at one of Cirex's casting stations in the Netherlands has a diameter of 10 metres and weighs 30 tonnes. It is driven by a CR. A special bearing has been fitted to handle the high breakdown moment as a result of the uneven load.



Flat heavy duty rotary table with large central opening. A real powerhouse. User-programmable. The flat design frees up space for ergonomically optimal workplaces.

ADVANTAGES

- Extremely flat design
- Large central opening for optimum feed-through of supply cables
- Extremely smooth and quiet running (<70 dBA)
- Splashproof
- Covered gaskets for protection from welding sparks
- The flexible motor flange principle makes it easy to connect third-party motors
- Maximum power transmission with zero backlash thanks to multiple cam rollers that are tensioned against one another and meshed
- Highest parts and repeat accuracy
- CR range with available manual hand crank
- Impressive price-performance
- Mounted on high-precision needle bearings to handle the heaviest loads in both the axial and radial direction
- Permanent status monitoring through W.A.S. 2 – WEISS Application Software mit unserem Standard-Steuerungspaket

GENERAL INFORMATION

- CR/TH heavy duty rotary indexing tables are user-programmable
- CR/TH heavy duty rotary indexing tables are "lubricated for life"!
- Freely accessible square shaft available for attaching a hand-wheel or hand crank (except on CR0400 model).

OPTIONS

- Possible installation location: vertical rotary axis (please consult WEISS for overhead or other installation positions).
- Additional rotary encoder option: standard manufacturer Heidenhain, type ROQ 425 with the EnDat 2.1 interface (other types or manufacturers available on request).
- For a surcharge, a positioning accuracy measurement report can also be drawn up and a compensation table incorporated for error compensation in a further step. However, this requires a mechanical zero point alignment.
- Standard colour: RAL7035 (other colours available on request)

CR 300E

TECHNICAL DATA

$n_{1\text{Max}}$	Max. motor speed:	2000 1/min
$n_{2\text{Max}}$	Max. output speed:	15.5 1/min
i_{tot}	Overall gear ratio:	130.2
	Indexing precision:	60 arcsec ($\pm 30''$)
A_r	Axial run-out of the drive flange:	(at $\varnothing 280$ mm) 0.01 mm
C_r	Concentricity of the output flange:	0.01 mm
m	Total weight, including motor:	approximately 210 kg

The values stated for axial run-out and concentricity can only be achieved with precise mounting surfaces.

LOAD DATA (for the stationary central part)

T_{SP}	Permitted torque:	150 Nm
M_{TSP}	Permitted tilting moment:	300 Nm
F_{ASP}	Permitted axial force:	6500 N
F_{RSP}	Permitted radial force:	3500 N

Combined loads and permitted process forces only after inspection by WEISS.

LOAD DATA (for the output flange)

$M_{2\text{T dyn}}$	Permitted dynamic tilting moment:	3000 Nm
$F_{2\text{A dyn}}$	Permitted dynamic axial force:	20000 N
$F_{2\text{R dyn}}$	Permitted dynamic radial force:	5500 N

TIMING DIAGRAM (please contact us for other requests)

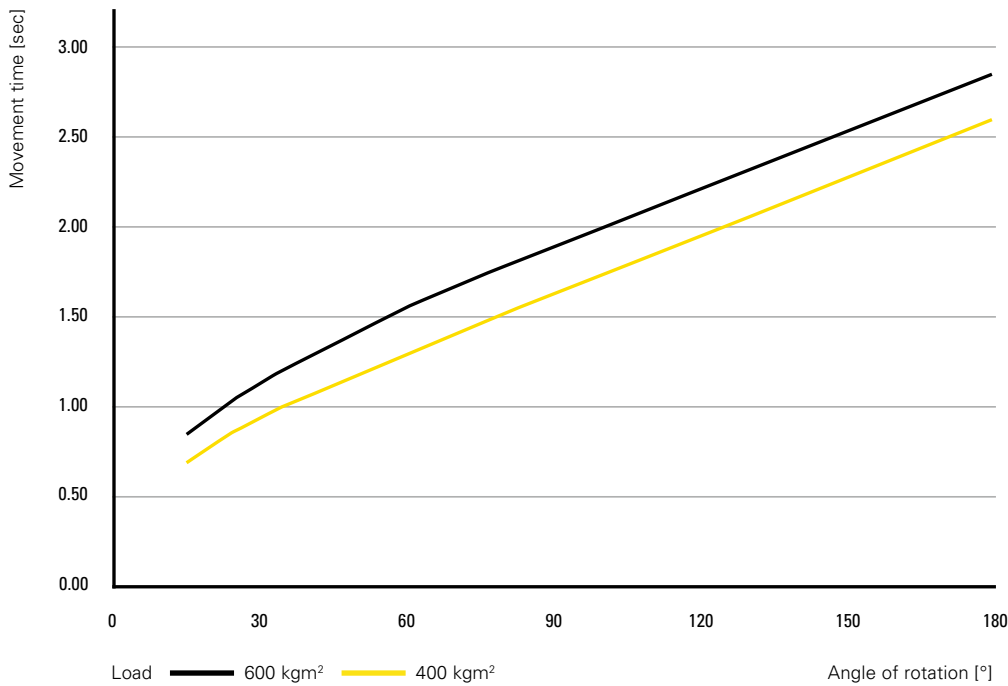

DIMENSIONS

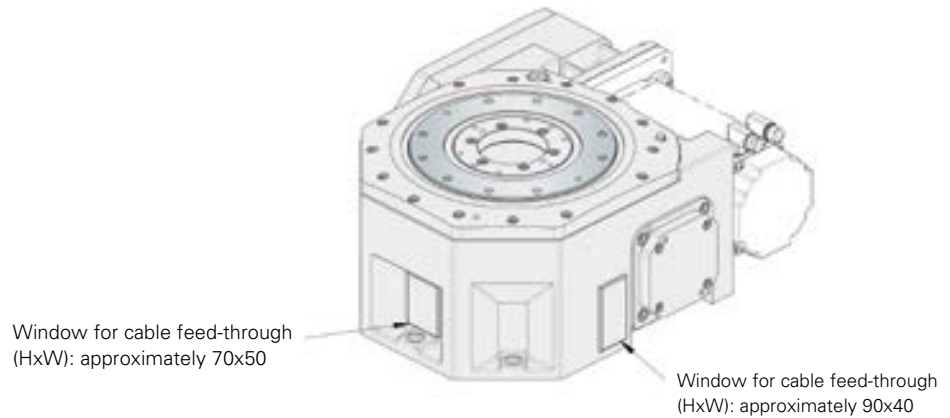

Square 24 mm shaft for hand crank below the cover

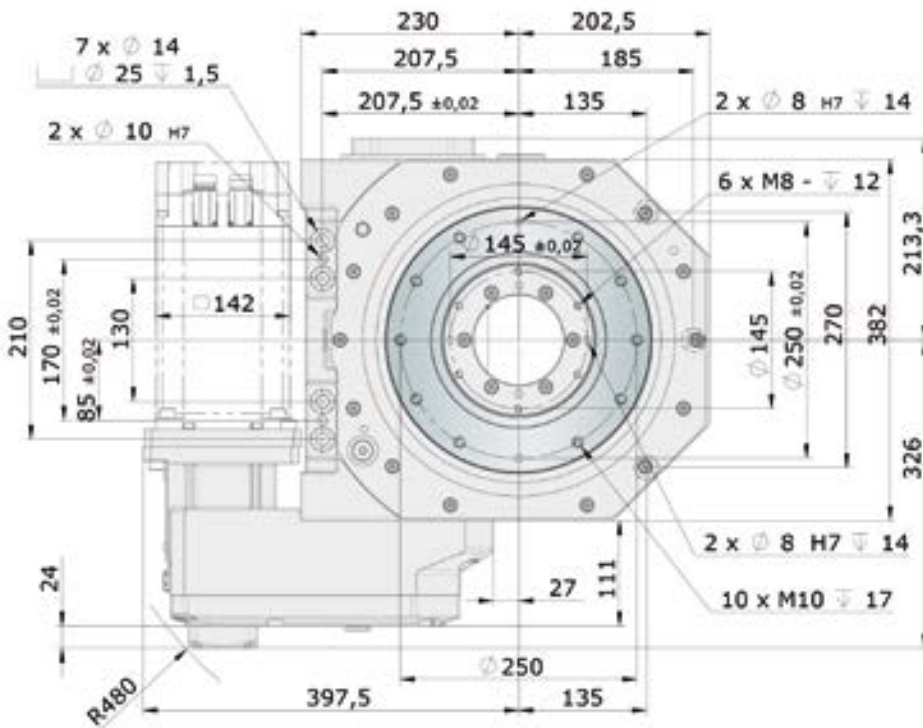
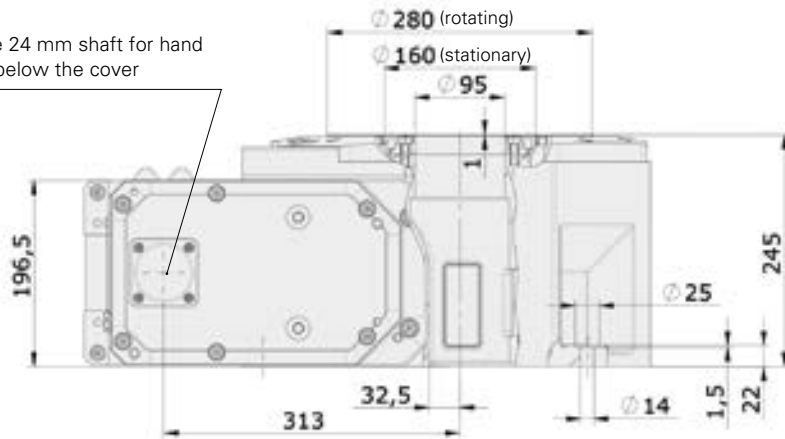

It is possible to fit popular alternative motors from various manufacturers. The drive flange geometries are motor-dependent. A taller central section is available on request.

CR 400E

TECHNICAL DATA

$n_{1\text{Max}}$	Max. motor speed:	3000 1/min
$n_{2\text{Max}}$	Max. output speed:	13.5 1/min
i_{tot}	Overall gear ratio:	222.04
	Indexing precision:	100 arcsec ($\pm 50''$)
	Axial run-out of the drive flange:	30 arcsec ($\pm 15''$)
A_r	Concentricity of the output flange:	(at $\varnothing 400$ mm) 0.015 mm
C_r	Total weight, including motor:	0.015 mm
m	Gesamtgewicht inkl. Motor:	approximately 300 kg

The values stated for axial run-out and concentricity can only be achieved with precise mounting surfaces.

LOAD DATA (for the stationary central part)

T_{SP}	Permitted torque:	300 Nm
$M_{\text{T SP}}$	Permitted tilting moment:	650 Nm
$F_{\text{A SP}}$	Permitted axial force:	10000 N
$F_{\text{R SP}}$	Permitted radial force:	6000 N

Combined loads and permitted process forces only after inspection by WEISS.

LOAD DATA (for the output flange)

$M_{\text{2T dyn}}$	Permitted dynamic tilting moment:	3000 Nm
$F_{\text{2A dyn}}$	Permitted dynamic axial force:	30000 N
$F_{\text{2R dyn}}$	Permitted dynamic radial force:	8000 N

TIMING DIAGRAM (please contact us for other requests)

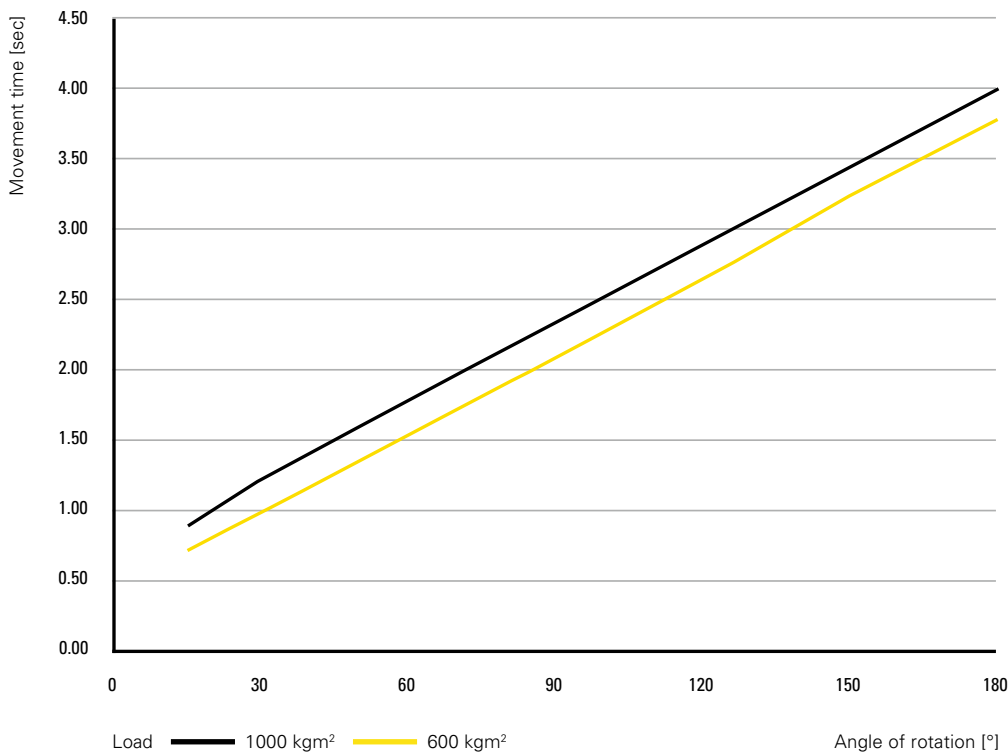

DIMENSIONS

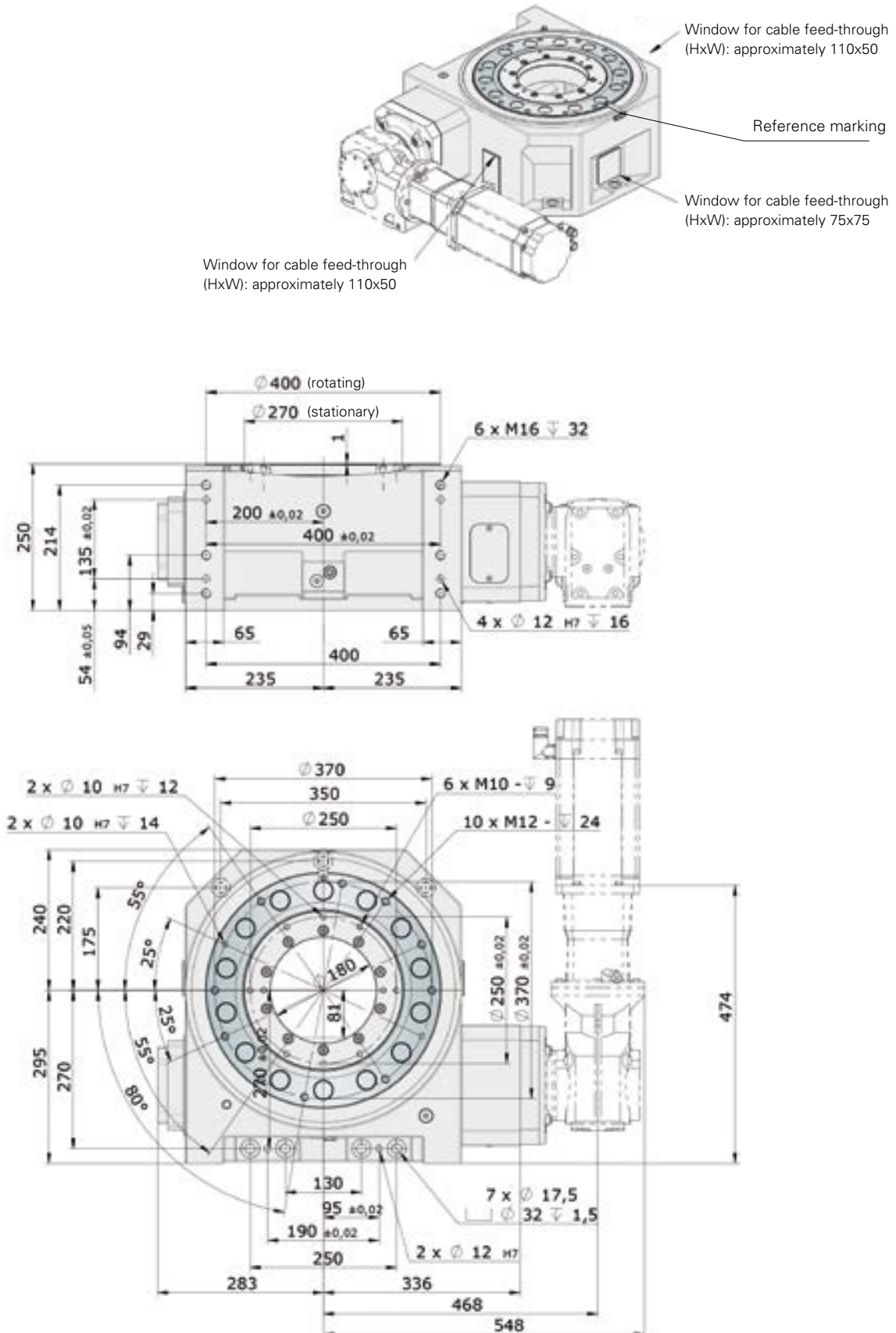

The shown position of the dial plate corresponds to the home position (state of delivery).
 It is possible to fit popular alternative motors from various manufacturers. The drive flange geometries are motor-dependent.
 A taller central section is available on request.

CR 500E

TECHNICAL DATA

$n_{1\text{Max}}$	Max. motor speed:	2000 1/min
$n_{2\text{Max}}$	Max. output speed:	13 1/min
i_{tot}	Overall gear ratio:	163.69
	Indexing precision:	50 arcsec ($\pm 25''$)
A_r	Axial run-out of the drive flange:	(at $\varnothing 445$ mm) 0.015 mm
C_r	Concentricity of the output flange:	0.015 mm
m	Total weight, including motor:	approximately 420 kg

The values stated for axial run-out and concentricity can only be achieved with precise mounting surfaces.

LOAD DATA (for the stationary central part)

T_{SP}	Permitted torque:	500 Nm
M_{TSP}	Permitted tilting moment:	1500 Nm
F_{ASP}	Permitted axial force:	18000 N
F_{RSP}	Permitted radial force:	10000 N

Combined loads and permitted process forces only after inspection by WEISS.

LOAD DATA (for the output flange)

$M_{2T\text{dyn}}$	Permitted dynamic tilting moment:	3500 Nm
$F_{2A\text{dyn}}$	Permitted dynamic axial force:	40000 N
$F_{2R\text{dyn}}$	Permitted dynamic radial force:	15000 N

TIMING DIAGRAM (please contact us for other requests)

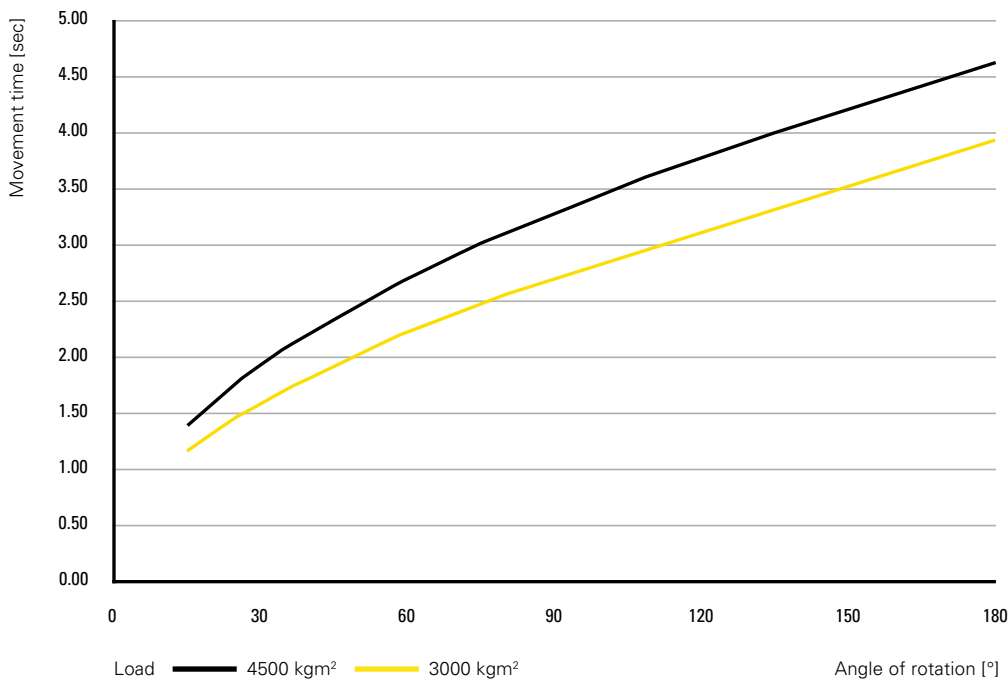

CR 700C

TECHNICAL DATA

$n_{1\text{Max}}$	Max. motor speed:	2000 1/min
$n_{2\text{Max}}$	Max. output speed:	14 1/min
i_{tot}	Overall gear ratio:	144
	Indexing precision:	30 arcsec ($\pm 15''$)
A_r	Axial run-out of the drive flange:	(at $\varnothing 700$ mm) 0.02 mm
C_r	Concentricity of the output flange:	0.02 mm
m	Total weight, including motor:	approximately 630 kg

The values stated for axial run-out and concentricity can only be achieved with precise mounting surfaces.

LOAD DATA (for the stationary central part)

T_{SP}	Permitted torque:	1700 Nm
M_{TSP}	Permitted tilting moment:	3500 Nm
F_{ASP}	Permitted axial force:	35000 N
F_{RSP}	Permitted radial force:	19000 N

Combined loads and permitted process forces only after inspection by WEISS.

LOAD DATA (for the output flange)

$M_{2T\text{dyn}}$	Permitted dynamic tilting moment:	10000 Nm
$F_{2A\text{dyn}}$	Permitted dynamic axial force:	70000 N
$F_{2R\text{dyn}}$	Permitted dynamic radial force:	30000 N

TIMING DIAGRAM (please contact us for other requests)

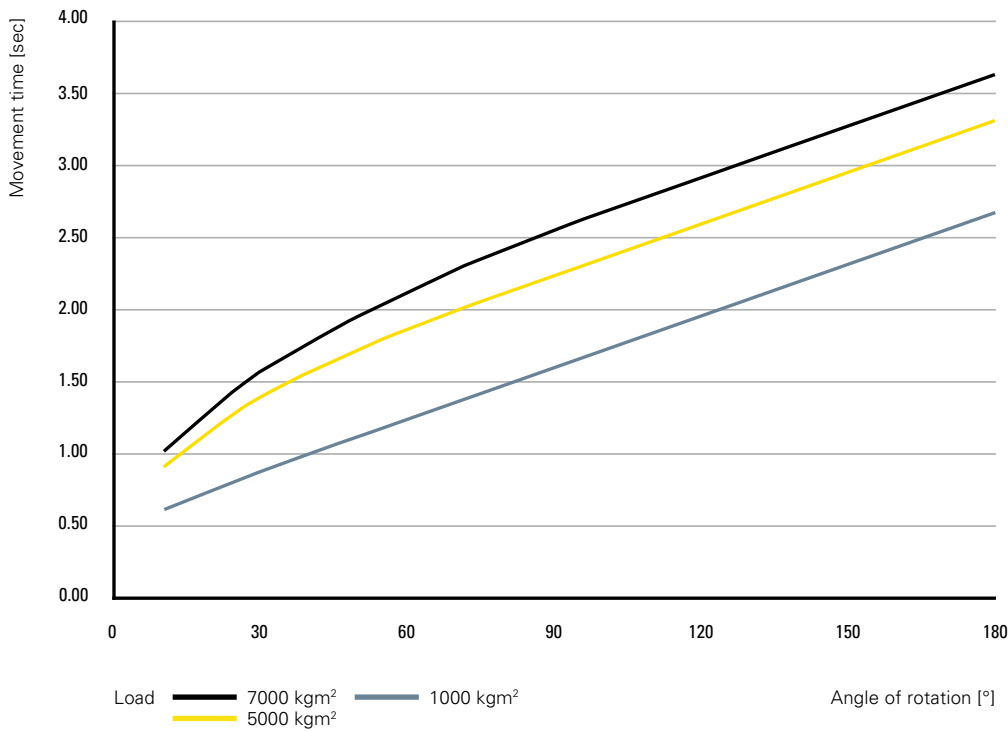

DIMENSIONS

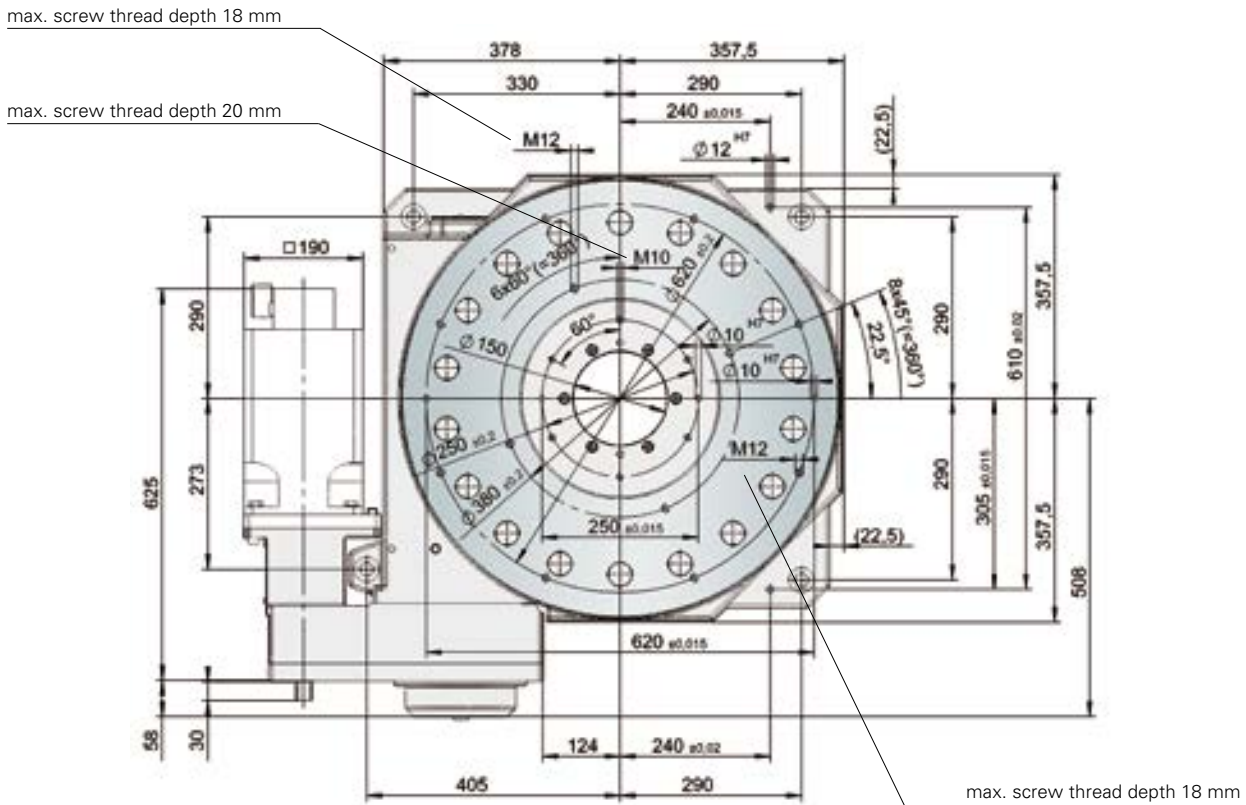
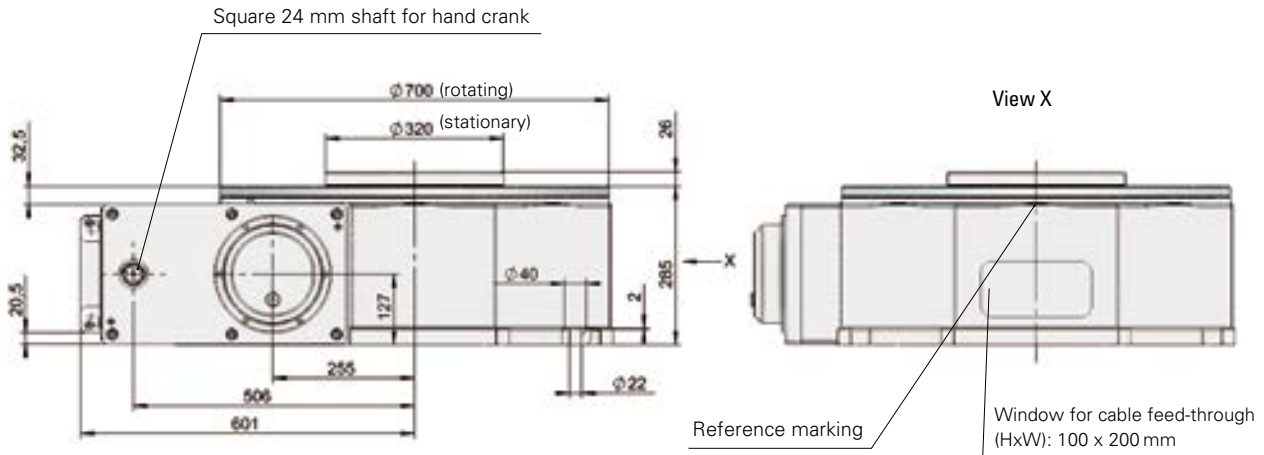

The shown position of the dial plate corresponds to the home position (state of delivery).
It is possible to fit popular alternative motors from various manufacturers.

CR 1000C

TECHNICAL DATA

$n_{1\text{Max}}$	Max. motor speed:	2400 1/min
$n_{2\text{Max}}$	Max. output speed:	12 1/min
i_{tot}	Overall gear ratio:	200
	Indexing precision:	30 arcsec ($\pm 15''$)
A_r	Axial run-out of the drive flange:	(at \varnothing 1000 mm) 0.03 mm
C_r	Concentricity of the output flange:	0.03 mm
m	Total weight, including motor:	approximately 1450 kg

The values stated for axial run-out and concentricity can only be achieved with precise mounting surfaces.

LOAD DATA (for the stationary central part)

T_{SP}	Permitted torque:	2000 Nm
M_{TSP}	Permitted tilting moment:	6000 Nm
F_{ASP}	Permitted axial force:	45000 N
F_{RSP}	Permitted radial force:	19000 N

Combined loads and permitted process forces only after inspection by WEISS.

LOAD DATA (for the output flange)

$M_{2T\text{dyn}}$	Permitted dynamic tilting moment:	25000 Nm
$F_{2A\text{dyn}}$	Permitted dynamic axial force:	120000 N
$F_{2R\text{dyn}}$	Permitted dynamic radial force:	100000 N

TIMING DIAGRAM (please contact us for other requests)

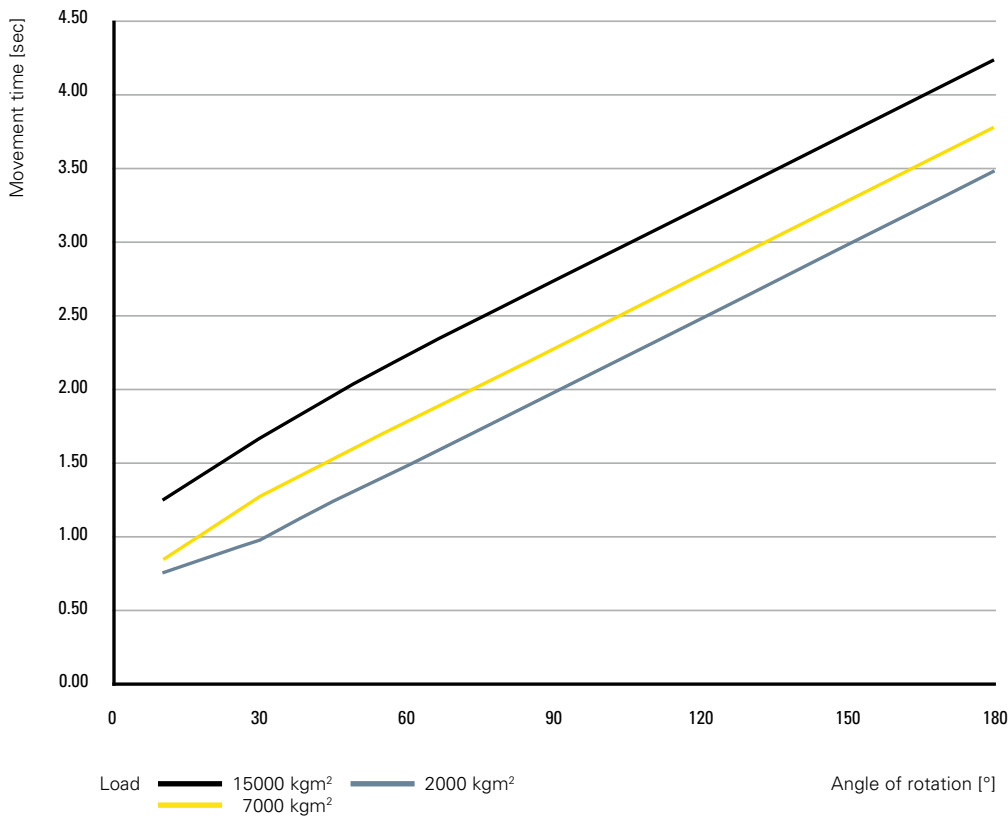

DIMENSIONS

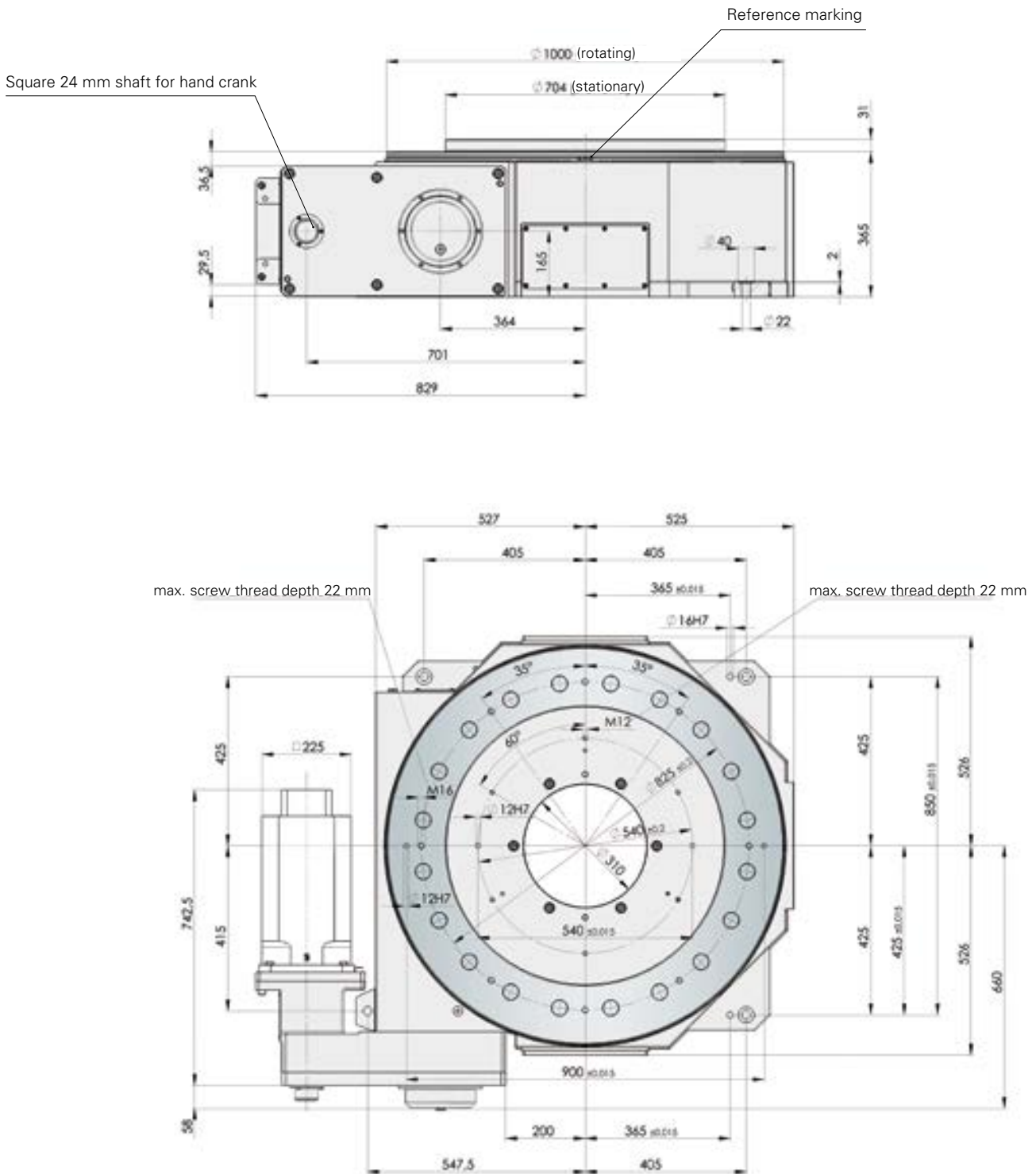

The shown position of the dial plate corresponds to the home position (state of delivery).
 The motor dimensions refer to the model 8LSA84.E1022D200-0 by B&R.
 It is possible to fit alternative motors from various manufacturers.

CR 1300C

TECHNICAL DATA

$n_{1 \text{ Max}}$	Max. motor speed:	2000 1/min
$n_{2 \text{ Max}}$	Max. output speed:	11 1/min
i_{tot}	Overall gear ratio:	180
	Indexing precision:	24 arcsec ($\pm 12''$)
A_r	Axial run-out of the drive flange:	(at \varnothing 1248 mm) 0.03 mm
C_r	Concentricity of the output flange:	0.03 mm
m	Total weight, including motor:	approximately 2000 kg

The values stated for axial run-out and concentricity can only be achieved with precise mounting surfaces.

LOAD DATA (for the output flange)

$M_{2T \text{ dyn}}$	Permitted dynamic tilting moment:	35000 Nm
$F_{2A \text{ dyn}}$	Permitted dynamic axial force:	150000 N
$F_{2R \text{ dyn}}$	Permitted dynamic radial force:	100000 N

TIMING DIAGRAM (please contact us for other requests)

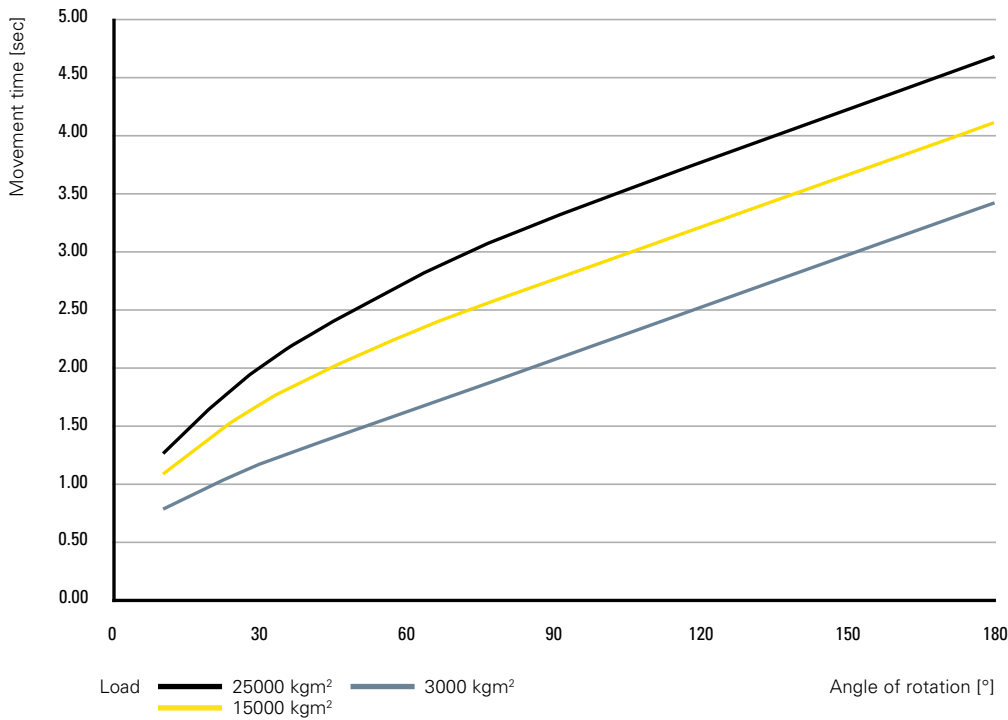

DIMENSIONS

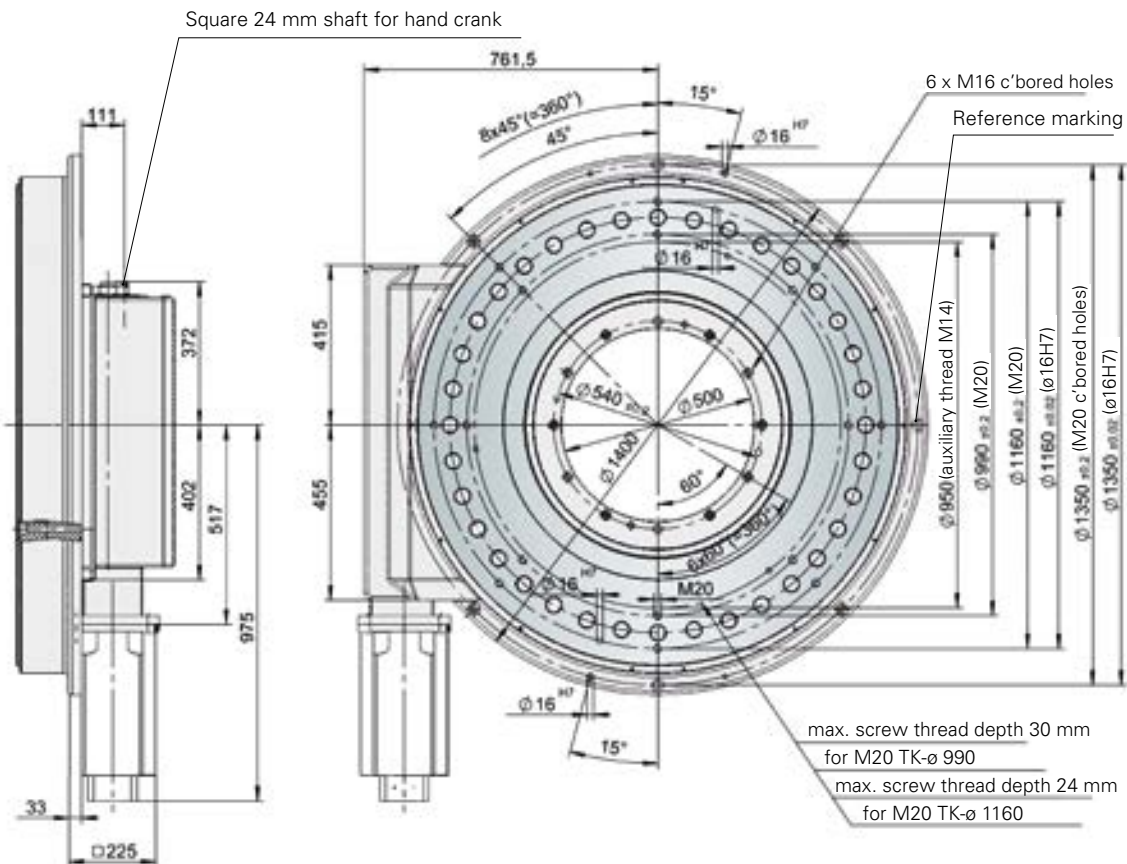
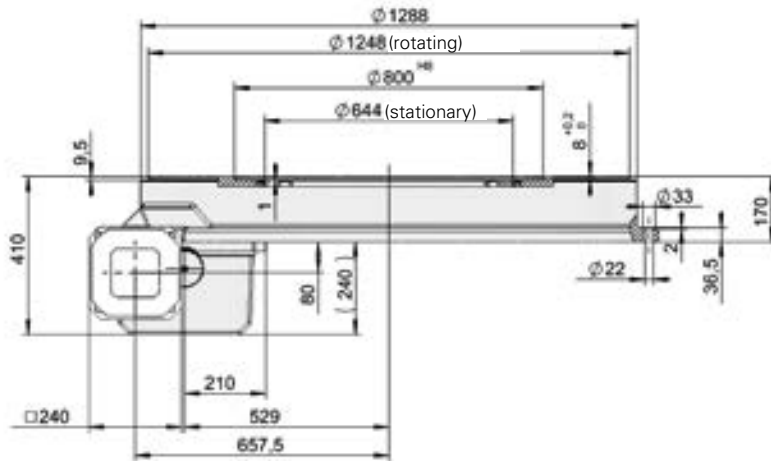

The shown position of the dial plate corresponds to the home position (state of delivery). The motor dimensions refer to the model 8LSA84.E1022D200-0 by B&R. It is possible to fit alternative motors from various manufacturers. An additional reduction gear may be required with several motors.

CR 2000C

TECHNICAL DATA

n_{1 Max}	Max. motor speed:	2000 1/min
n_{2 Max}	Max. output speed:	6.5 1/min
i_{tot}	Overall gear ratio:	310
	Indexing precision:	20 arcsec ($\pm 10''$)
A_r	Axial run-out of the drive flange:	(at $\varnothing 1874$ mm) 0.03 mm
C_r	Concentricity of the output flange:	0.03 mm
m	Total weight, including motor:	approximately 3600 kg

The values stated for axial run-out and concentricity can only be achieved with precise mounting surfaces.

LOAD DATA (for the output flange)

M_{2T dyn}	Permitted dynamic tilting moment:	55000 Nm
F_{2A dyn}	Permitted dynamic axial force:	250000 N
F_{2R dyn}	Permitted dynamic radial force:	125000 N

TIMING DIAGRAM (please contact us for other requests)

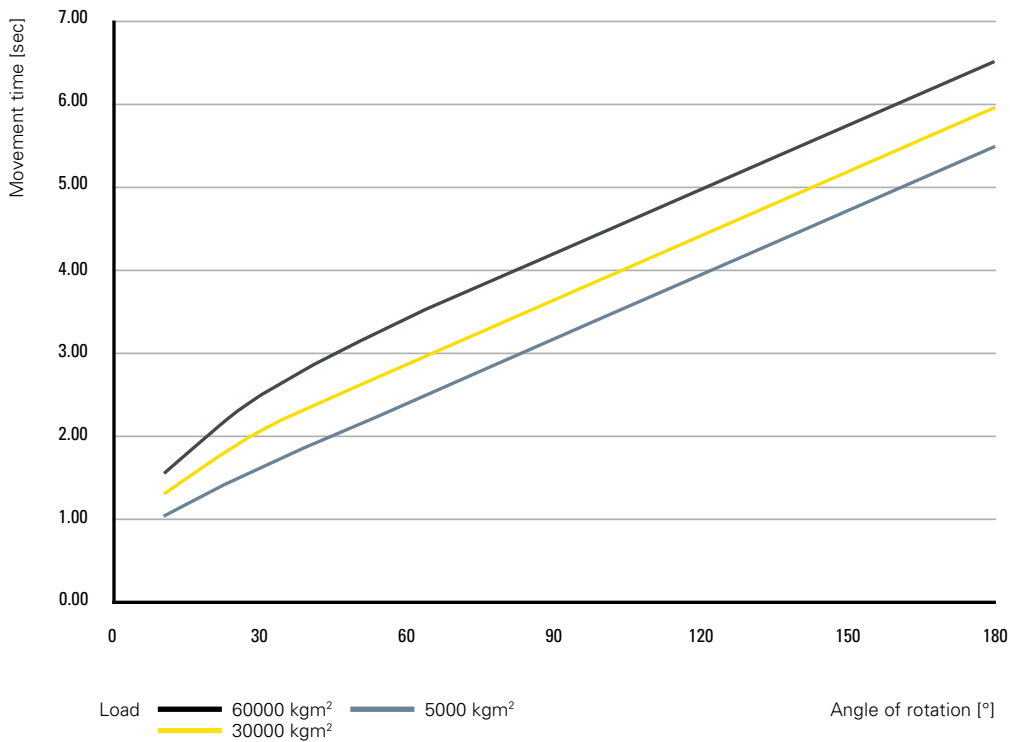

DIMENSIONS

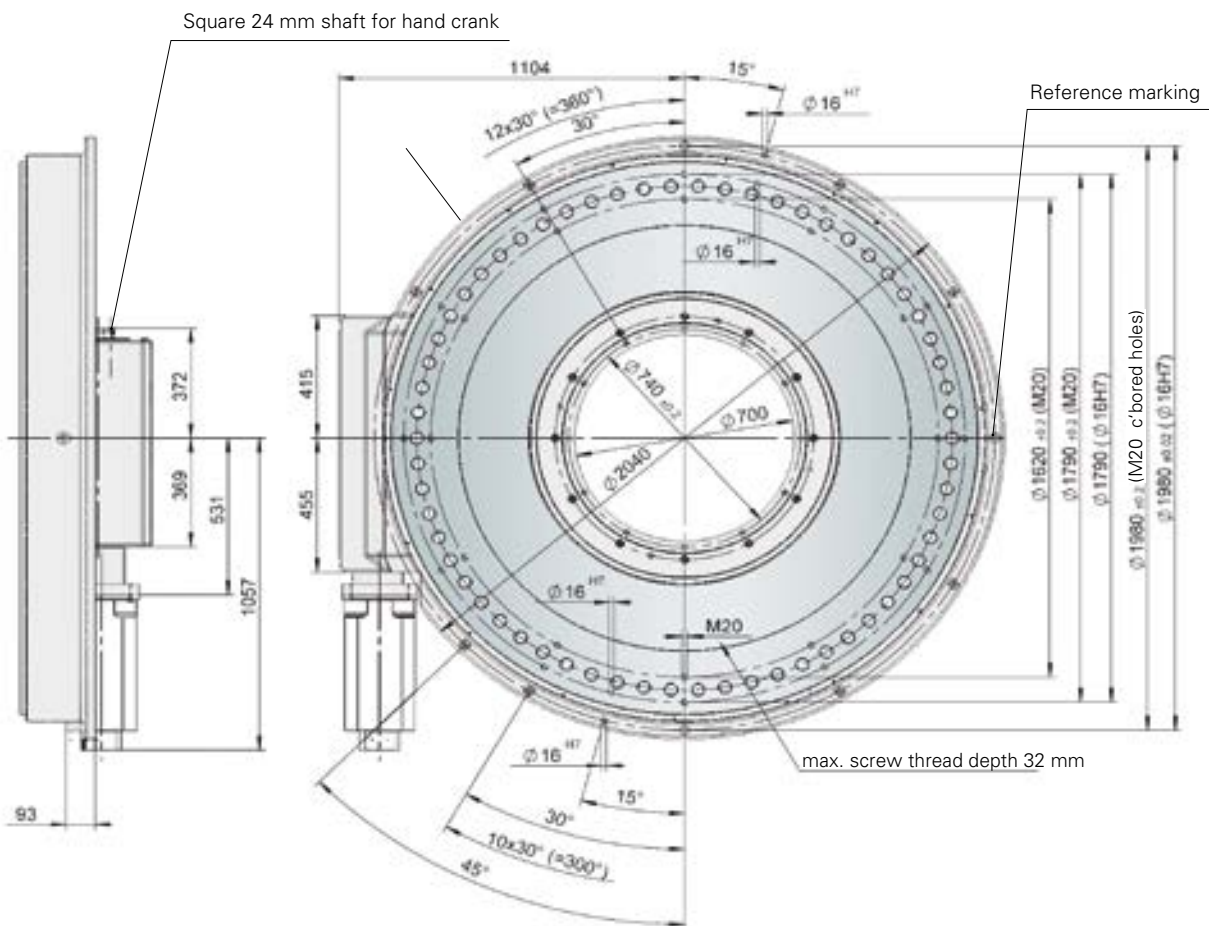
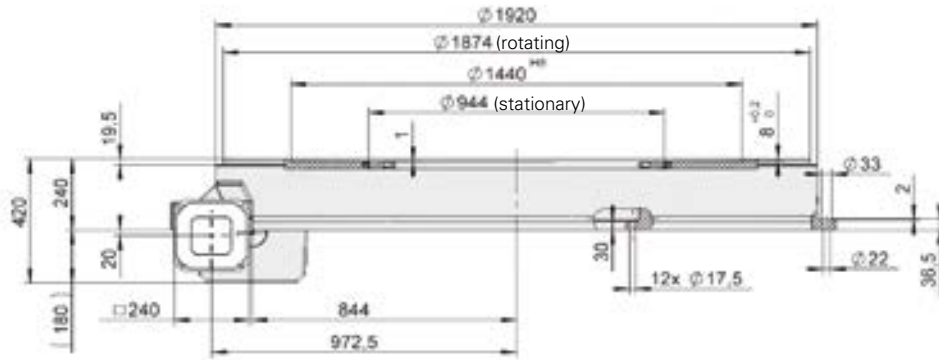

The shown position of the dial plate corresponds to the home position (state of delivery).
 The motor dimensions refer to the model 8LSA84.E1022D200-0 by B&R. It is possible to fit alternative motors from various manufacturers. An additional reduction gear may be required with several motors.

TH 700F

TECHNICAL DATA

$n_{1\text{Max}}$	Max. motor speed:	2000 1/min
$n_{2\text{Max}}$	Max. output speed:	14 1/min
i_{tot}	Overall gear ratio:	144
	Indexing precision:	30 arcsec ($\pm 15''$)
A_r	Axial run-out of the drive flange:	(at $\varnothing 700$ mm) 0.02 mm
C_r	Concentricity of the output flange:	0.02 mm
m	Total weight, including motor:	approximately 630 kg

The values stated for axial run-out and concentricity can only be achieved with precise mounting surfaces.

LOAD DATA (for the stationary central part)

T_{SP}	Permitted torque:	1700 Nm
M_{TSP}	Permitted tilting moment:	3500 Nm
F_{ASP}	Permitted axial force:	35000 N
F_{RSP}	Permitted radial force:	19000 N

Combined loads and permitted process forces only after inspection by WEISS.

LOAD DATA (for the output flange)

$M_{2T\text{dyn}}$	Permitted dynamic tilting moment:	10000 Nm
$F_{2A\text{dyn}}$	Permitted dynamic axial force:	70000 N
$F_{2R\text{dyn}}$	Permitted dynamic radial force:	30000 N

TIMING DIAGRAM (please contact us for other requests)

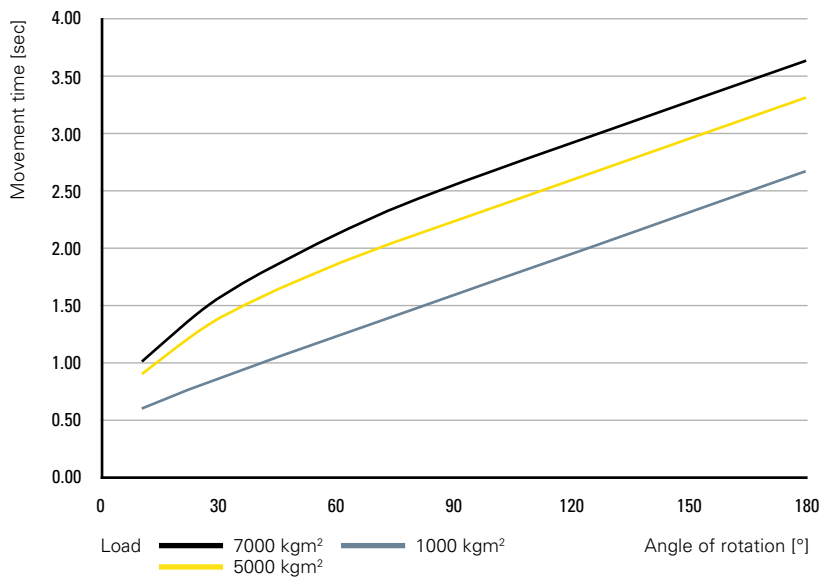

DIMENSIONS

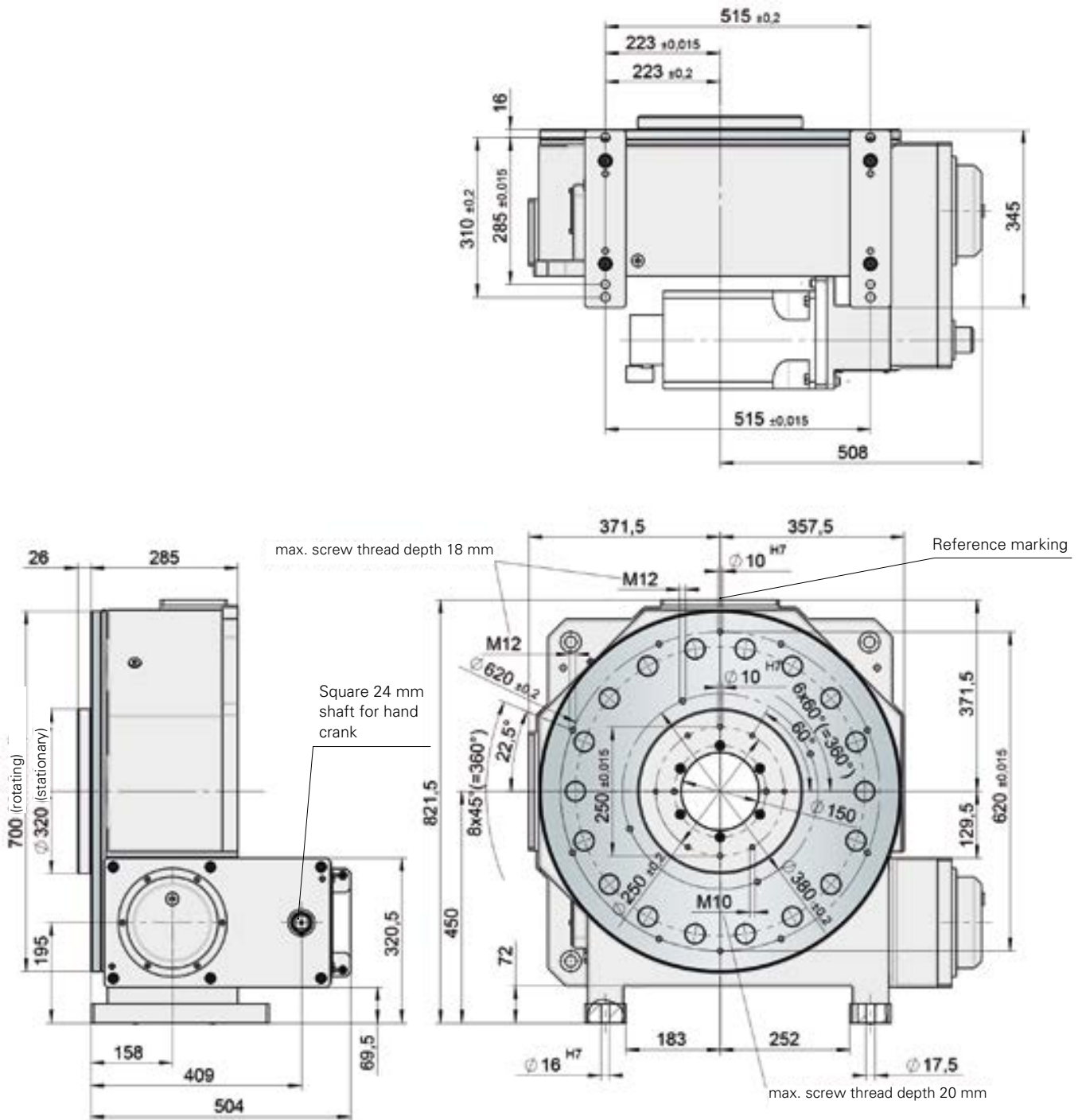

The shown position of the dial plate corresponds to the home position (state of delivery).

It is possible to fit popular alternative motors from various manufacturers. The drive flange geometries are motor-dependent.

TH 1000F

TECHNICAL DATA

$n_{1\text{Max}}$	Max. motor speed:	2400 1/min
$n_{2\text{Max}}$	Max. output speed:	12 1/min
i_{tot}	Overall gear ratio:	200
	Indexing precision:	30 arcsec ($\pm 15''$)
A_r	Axial run-out of the drive flange:	(at \varnothing 1000 mm) 0.03 mm
C_r	Concentricity of the output flange:	0.03 mm
m	Total weight, including motor:	approximately 1500 kg

The values stated for axial run-out and concentricity can only be achieved with precise mounting surfaces.

LOAD DATA (for the stationary central part)

T_{SP}	Permitted torque:	2000 Nm
M_{TSP}	Permitted tilting moment:	6000 Nm
F_{ASP}	Permitted axial force:	45000 N
F_{RSP}	Permitted radial force:	19000 N

Combined loads and permitted process forces only after inspection by WEISS.

LOAD DATA (for the output flange)

$M_{2T\text{ dyn}}$	Permitted dynamic tilting moment:	25000 Nm
$F_{2A\text{ dyn}}$	Permitted dynamic axial force:	120000 N
$F_{2R\text{ dyn}}$	Permitted dynamic radial force:	100000 N

TIMING DIAGRAM (please contact us for other requests)

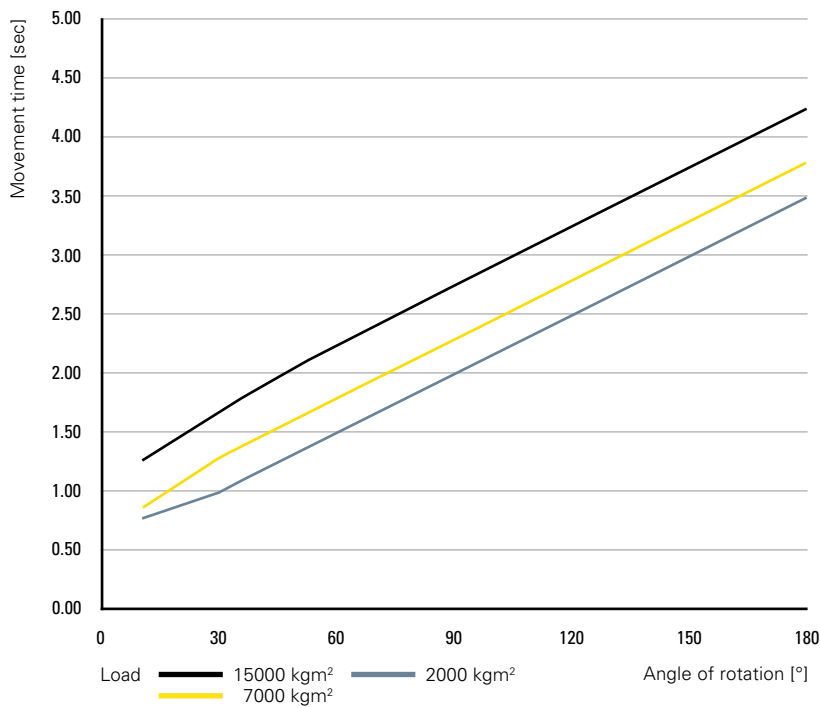

DIMENSIONS

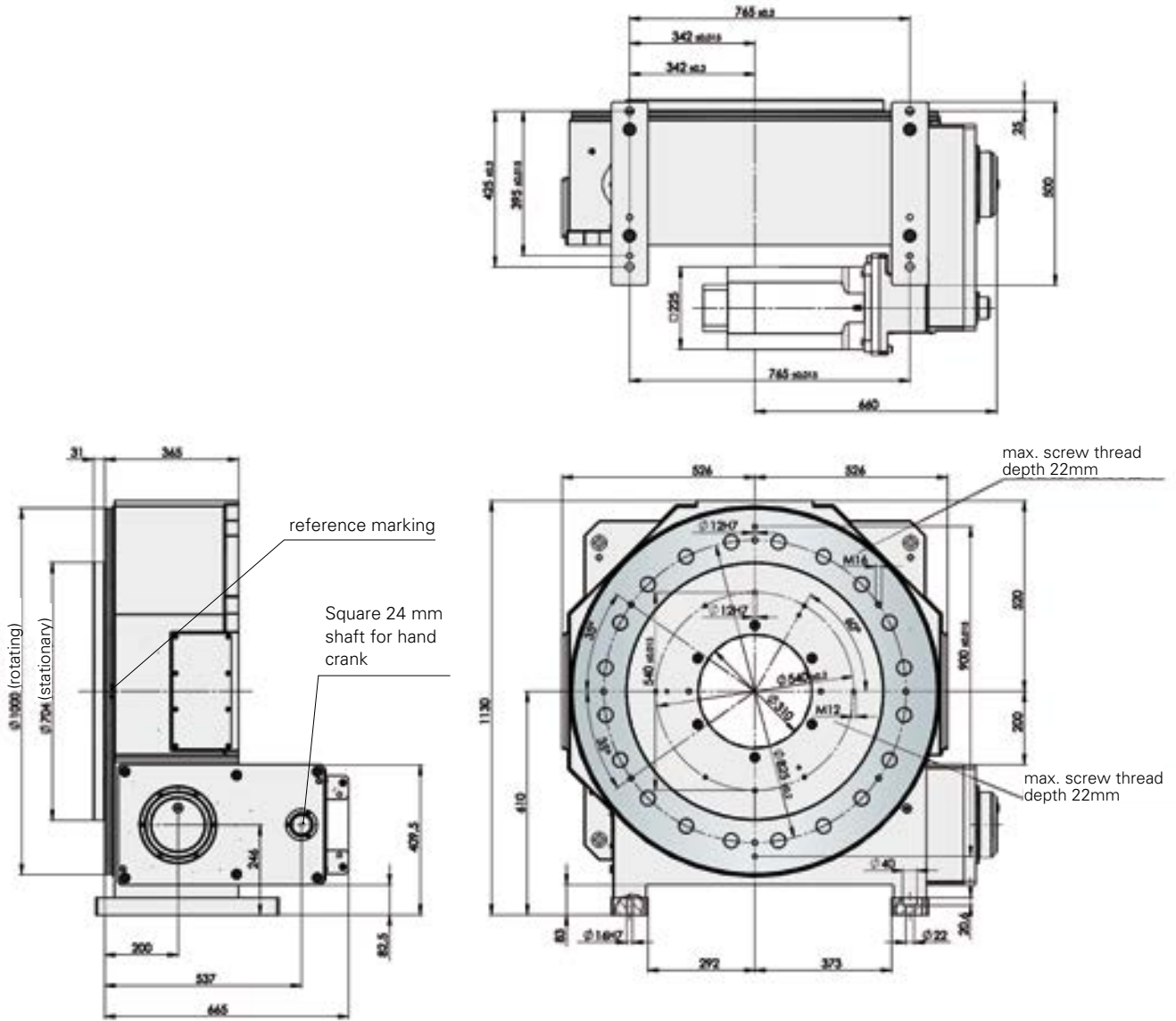

The shown position of the dial plate corresponds to the home position (state of delivery).

It is possible to fit popular alternative motors from various manufacturers. The drive flange geometries are motor-dependent.