

TC

FIXED-STATION ROTARY INDEXING TABLES | TC ROTARY INDEXING TABLE



TC ROTARY INDEXING TABLE: RELIABILITY FOR A LIFETIME

EXTENDED WARRANTY

Using our rotary table control system minimises brake wear. This makes the rotary indexing table virtually maintenance-free throughout its entire service life. And using this control system also extends the warranty to four years.





Custom machine for an automotive supplier. The assembly of sealing rings for injection pumps requires maximum precision. The TC 150 rotary indexing table with matched rotating plate delivers this.

One of the most reliable and robust rotary indexing tables available worldwide. Your most popular partner in the field of automation technology. Extremely long service life combined with impressively fast switching. Now in its third generation. Robust rotary indexing table with smooth, jerk and impact-free running and extremely long service life. When using a WEISS rotary table control system, we extend the warranty from one to four years.

ADVANTAGES

- Powerful upright centre part
- Large central bore and opening in the housing for media feed-through on models TC0120 to TC0320
- Plate gasket with soiling lip
- Precise, high-load plate bearing
- Cam rollers mounted on needle bearings
- Grey iron housing
- Hardened plates, soft mounting surface
- EWR electronic wear compensation
- Extremely high precision which always comes with an approval certificate.

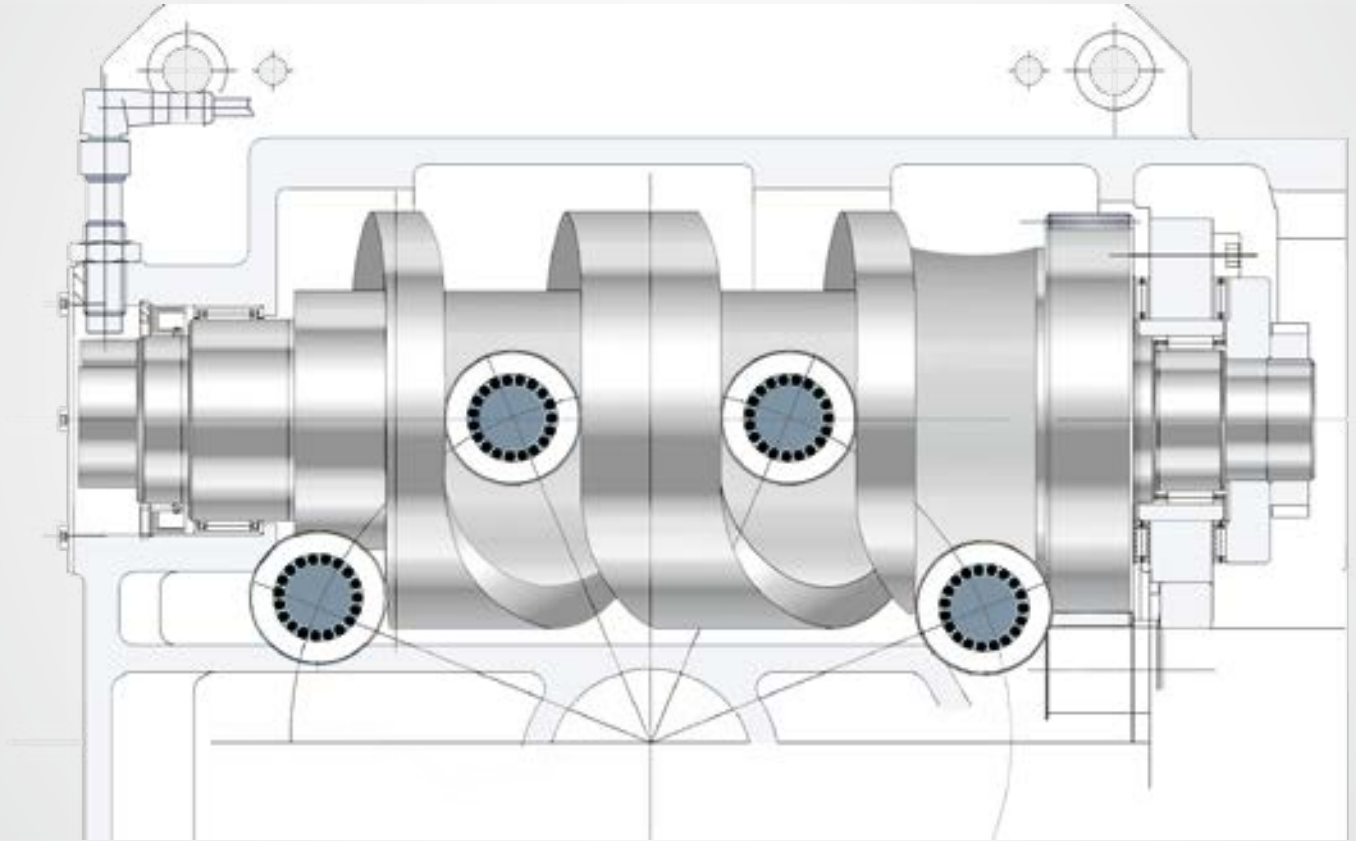

The TC is one of the most reliable and robust rotary indexing tables available worldwide. Our roller cam drives are dimensioned as large as possible. And the full length of the cams is used here.

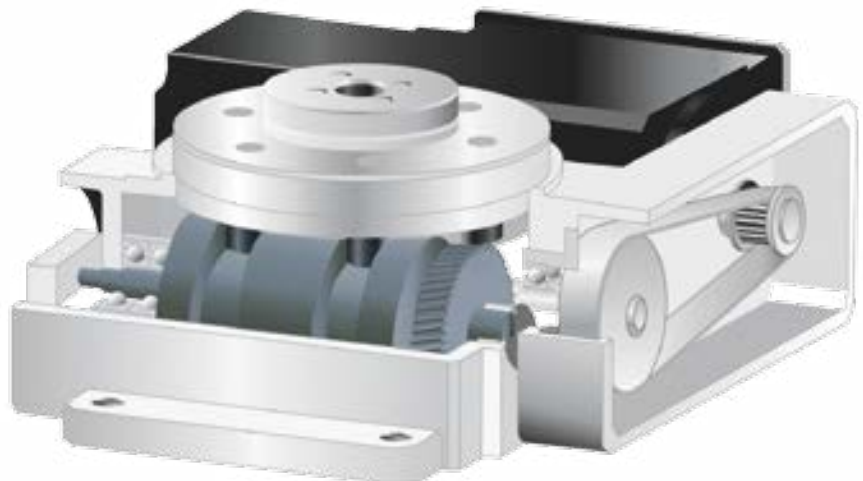

The fastest switching times and an extremely long service life – we achieve this with high-precision drive cams made by our in-house manufacturing department.

DELIVERS WHAT IT PROMISES – THAT'S A PROMISE.

GENERAL INFORMATION ON THE MODEL RANGE

- TC rotary indexing tables can be operated clockwise, anti-clockwise and also in reversing mode.
- The drive can be swung downward. You can do the conversion work yourself.
- The TC rotary indexing tables are "lubricated for life"!
- The maximum switching frequency is up to 220 cycles per minute, depending on the size, the system's mass moment of inertia and the angle of rotation.
- All TC rotary indexing tables are equipped with asynchronous brake motors. The size of the motors is optimally matched to the respective rotary indexing table configuration, so the drive can never damage the rotary indexing table.
- The maximum stated radial force and torque of the stationary central section and the output flange refer only to the rotary indexing table.
- When determining the maximum actual load of the overall system, the influence of the plate material and the plate attachment means must also be taken into account.
- We would be happy to advise and support you in dimensioning your overall system.
- Note on indexing times (TC 120-TC 500): The actual measured rotation time (from the start signal to the electrical in-position signal) comprises the calculated rotation motion time given in the tables and type-related delays. Electrical signal processing times, as well as setting up and optimising the ideal start position represent an important part.

OPTIMISED BEARINGS

To achieve maximum quality and reliability, even when under load, all roller bearings run in an oil bath and the plate cam rollers are mounted on needle bearings.



GENTLE MOVEMENTS

Thanks to the cam profile with modified sine wave, we are able to achieve very gentle and smooth movements. This is the prerequisite for the fastest indexing times and a long service life.

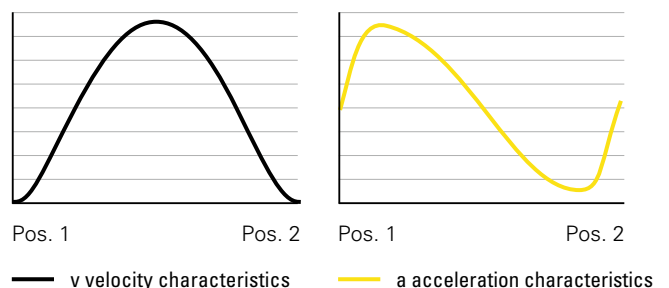

VERSIONS: DRIVE POSITION

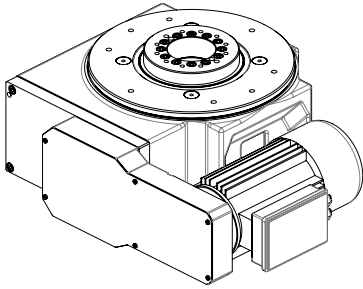

LATERAL INSIDE/DP 1

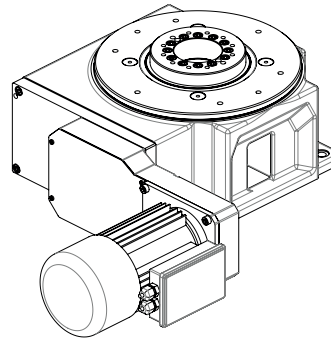

LATERAL OUTSIDE/DP 2

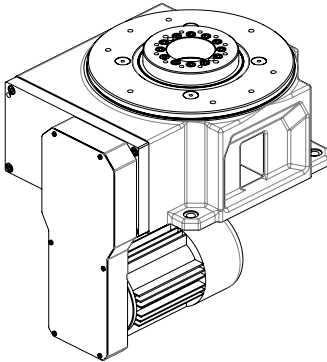

BELOW INSIDE/DP 3

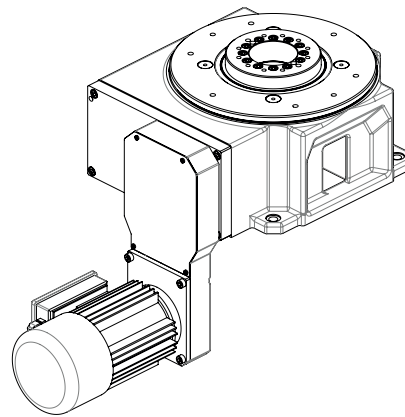

BELOW OUTSIDE/DP 4

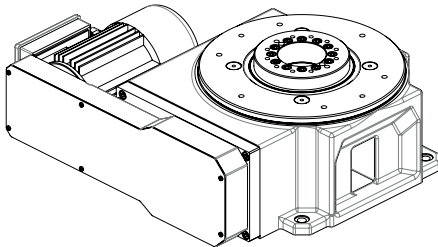

LATERAL INSIDE
MOTOR ON CAM SIDE/DP 5

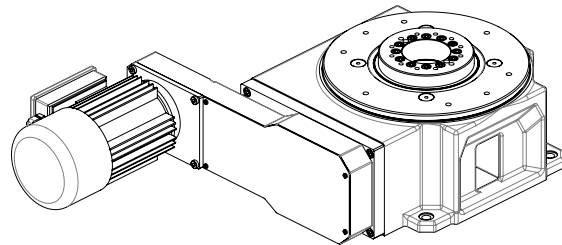

LATERAL OUTSIDE
LONG DRIVE HOUSING/DP 6

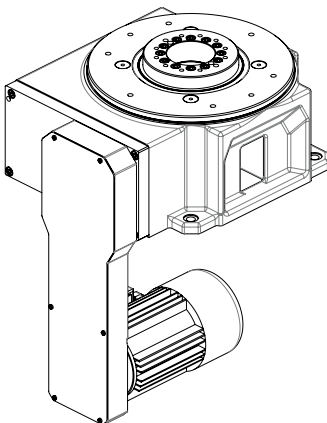

BELOW INSIDE
LONG DRIVE HOUSING/DP 7

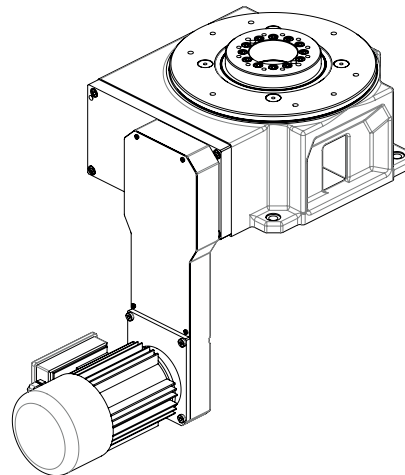

BELOW OUTSIDE
LONG DRIVE HOUSING/DP 8

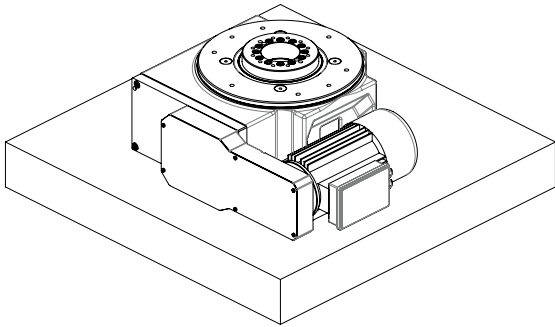
VERSIONS: MOUNTING POSITION

STANDARD /MP 1

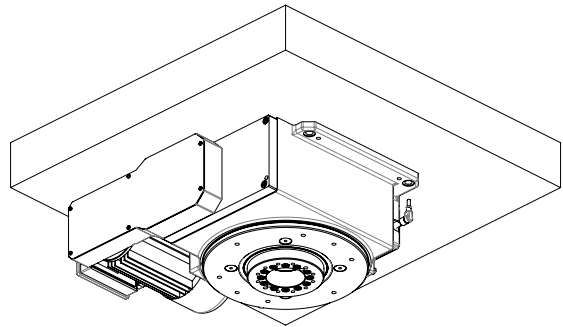

OVERHEAD /MP 2

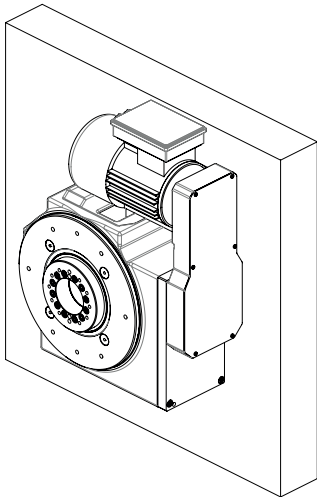

VERTICAL, DRIVE ON RIGHT /MP 3

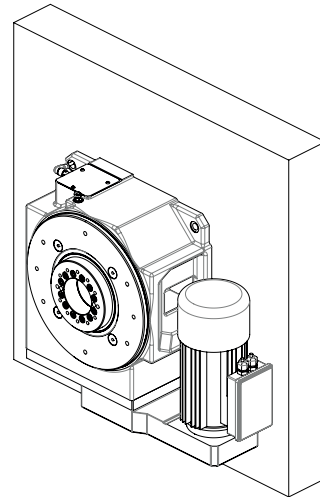

VERTICAL, DRIVE AT BASE /MP 4

OPTIONS

- If necessary, the stationary central section can be raised 5 mm or 10 mm.
- All sizes in the TC model range can optionally be equipped with a DRIVE-CLiQ absolute encoder.
- In connection with the new 2.1 version of the EF2 control system software, the rotary encoder offers the following options:
 - » Cam switching mechanism: 16 user-programmable electronic cams allow early triggering of process actuators or help reduce the cycle time with load-ing/unloading axes
 - » Segment detection: The index of the current nest is reflected in the locking position on the fieldbus or, where applicable, digital I/Os. This eliminates the need for retrofit equipment to determine the current position of the component nests on the rotating plate.
- Standard colour: RAL7035 (other colours available on request)
- Please get in touch with us if you are looking for a solution for cleanroom applications.

TC 120G



GENERAL INFORMATION

- Maximum recommended equipment diameter D_{tp} : approximately 600 mm
- Custom option for TC0120T: screw-on mounting from above (please request drawing)

TECHNICAL DATA

U	Voltage (custom voltages available on request):	230 / 400 V
f	Frequency:	50 Hz
	Indexing precision*:	Indexing 2-10: 90 arcsec ($\pm 45''$) Indexing 12-20: 110 arcsec ($\pm 55''$)
A_r	Axial run-out of the drive flange:	(at \varnothing 120 mm) 0.02 mm
C_r	Concentricity of the output flange:	0.02 mm
P	Parallelism between the output flange and screw-on surface of the housing:	(at \varnothing 120 mm) 0.04 mm
m	Total weight, including motor:	22 kg

* Positioning accuracy can be improved by 10 arcsec on request.

LOAD DATA (for the stationary central part)

Due to the necessary layout of the drilling pattern, the stationary central section should only be used for attaching sensor technology or similar small components.

Combined loads and permitted process forces only after inspection by WEISS.

LOAD DATA (for the output flange)

T_{2 stat}	Static torque:	120 Nm
M_{2T dyn}	Permitted dynamic tilting moment:	200 Nm
F_{2A dyn}	Permitted dynamic axial force:	3300 N
F_{2R dyn}	Permitted dynamic radial force:	1500 N

LOAD TABLE 50 Hz (On request: higher loads / custom indexing and switching times for 60 hz mains frequency)

Indexing	Speed level	2-stage										
		s	a	b	c	d	e	f	g	h	i	j
2	J_{2 Max}	-	-	-	0.06	0.1	0.174	0.285	0.505	1.15	2.03	4.94
	t _i	-	-	-	0.41	0.51	0.63	0.78	0.99	1.42	1.81	2.66
4	J_{2 Max}	-	0.1 *	0.19	0.29	0.47	0.67	1.25	1.95	5.11	8.95	19.5
	t _i	-	0.24 *	0.31	0.37	0.46	0.57	0.70	0.89	1.28	1.63	2.39
5	J_{2 Max}	-	0.16 *	0.33	0.5	0.808	1.05	1.95	3	8.7	14.1	30.5
	t _i	-	0.24 *	0.31	0.37	0.46	0.57	0.70	0.89	1.28	1.63	2.39
6	J_{2 Max}	0.136 *	0.23 *	0.408	0.62	1	1.5	2.70	4.4	10.7	18.8	44
	t _i	0.21 *	0.24 *	0.31	0.37	0.46	0.57	0.70	0.89	1.28	1.63	2.39
8	J_{2 Max}	0.248 *	0.41 *	0.85	1.28	2.07	2.7	5	7.8	21.4	34.9	75.5
	t _i	0.21 *	0.24 *	0.31	0.37	0.46	0.57	0.70	0.89	1.28	1.63	2.39
10	J_{2 Max}	0.35 *	0.57 *	1	1.51	2.44	4.08	6.55	10.7	21.8	35.5	76.8
	t _i	0.21 *	0.24 *	0.31	0.37	0.46	0.57	0.70	0.89	1.28	1.63	2.39
12	J_{2 Max}	-	-	-	-	0.47 *	0.67	1.25	1.95	5.08	8.9	19.6
	t _i	-	-	-	-	0.22 *	0.27	0.34	0.43	0.61	0.78	1.15
16	J_v	-	-	-	-	0.55 *	0.92	1.49	2.6	5.9	10.3	25.2
	t _i	-	-	-	-	0.22 *	0.27	0.34	0.43	0.61	0.78	1.15
20	J_{2 Max}	-	-	-	-	0.86 *	1.44	2.32	4.06	9.2	16.1	35.5
	t _i	-	-	-	-	0.22 *	0.27	0.34	0.43	0.61	0.78	1.15

J_{2 Max} = max admissible mass inertia loading (kgm²) **t_i** = cycle time (sec.) Depending on motor size, electronics and time optimisation settings, the cycle time measured from the start signal to the electric position indication is approx. 80 - 130 ms longer than the value specified in the table (see also the note on page 17).

***EF2** - Control recommended to minimise brake wear (see page 48).

DIMENSIONS

If you require subsequent drilling work on the indexing table, please request information on permissible drilling depths. The illustrated rotating plate position corresponds to the basic position of the rotary indexing table (Position when delivered).

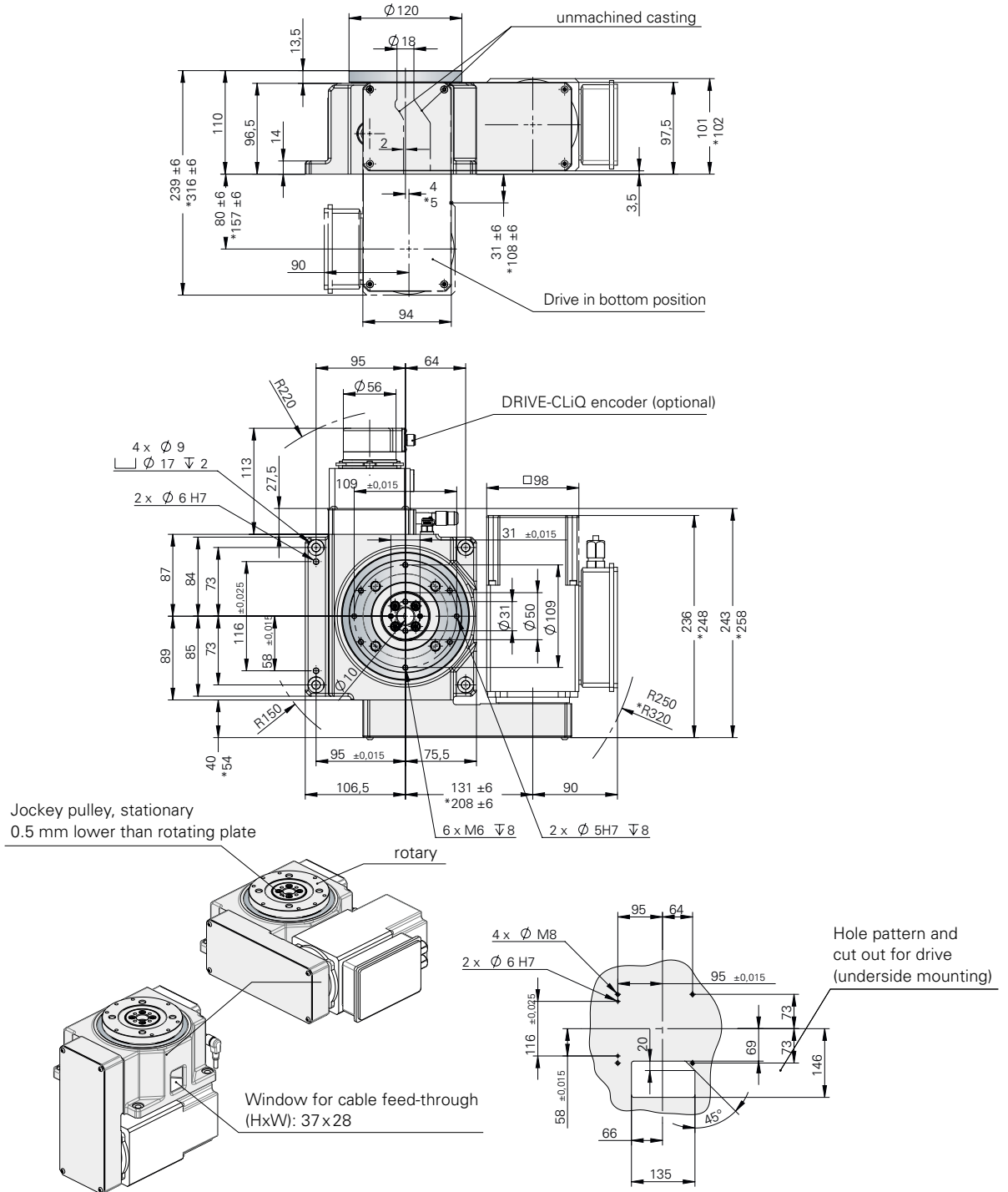

* Dimensions for speed levels: h, i, j (2-stage)

Max. centre line deviation between stationary centre section and dial: $\pm 180''$

Max. centre line deviation between dial and indexer housing: $\pm 120''$

Note: Please ensure motor and brake are accessible for servicing!

TC 150T



GENERAL INFORMATION

- Maximum recommended equipment diameter D_{tp} : approximately 800 mm
- Custom option for TC0150T: screw-on mounting from above (please request drawing)

TECHNICAL DATA

U	Voltage (custom voltages available on request):	230 / 400 V
f	Frequency:	50 Hz
	Indexing precision*:	Indexing 2-12: 60 arcsec ($\pm 30''$) Indexing 16-24: 90 arcsec ($\pm 45''$)
A_r	Axial run-out of the drive flange:	(at \varnothing 150 mm) 0.01 mm
C_r	Concentricity of the output flange:	0.01 mm
P	Parallelism between the output flange and screw-on surface of the housing:	(at \varnothing 150 mm) 0.03 mm
m	Total weight, including motor:	24 kg
D_i	Min. inside diameter of the rotary plate:	80 mm

* Positioning accuracy can be improved by 10 arcsec on request.

LOAD DATA (for the stationary central part)

T_{SP}	Permitted torque:	140 Nm
M_{T SP}	Permitted tilting moment:	200 Nm
F_{A SP}	Permitted axial force:	3500 N
F_{R SP}	Permitted radial force:	2500 N

Combined loads and permitted process forces only after inspection by WEISS.

LOAD DATA (for the output flange)

T_{2 stat}	Static torque:	150 Nm
M_{2T dyn}	Permitted dynamic tilting moment:	500 Nm
F_{2A dyn}	Permitted dynamic axial force:	5500 N
F_{2R dyn}	Permitted dynamic radial force:	6000 N

LOAD TABLE 50 Hz (On request: higher loads / custom indexing and switching times for 60 hz mains frequency)

Indexing	Speed level	2-stage										
		s	a	b	c	d	e	f	g	h	i	j
2	J_{2 Max}	-	-	-	0.09	0.149	0.255	0.415	0.73	1.67	2.93	7.12
	t _i	-	-	-	0.43	0.53	0.66	0.81	1.03	1.47	1.88	2.76
3	J_{2 Max}	-	-	-	0.14	0.23	0.39	0.63	1.1	2.53	4.43	10.7
	t _i	-	-	-	0.43	0.53	0.66	0.81	1.03	1.47	1.88	2.76
4	J_{2 Max}	-	0.11 *	0.23	0.37	0.59	0.75	1.4	2.17	6.4	11.3	26.4
	t _i	-	0.25 *	0.32	0.39	0.47	0.59	0.73	0.93	1.33	1.69	2.49
6	J_{2 Max}	0.155 *	0.26 *	0.53	0.8	1.29	1.69	3.15	4.9	13.9	24.3	59
	t _i	0.21 *	0.25 *	0.32	0.39	0.47	0.59	0.73	0.93	1.33	1.69	2.49
8	J_{2 Max}	0.28 *	0.46 *	0.96	1.62	2.61	3.02	5.61	8.71	25.3	48.8	105
	t _i	0.21 *	0.25 *	0.32	0.39	0.47	0.59	0.73	0.93	1.33	1.69	2.49
10	J_{2 Max}	0.44 *	0.72 *	1.42	2.14	3.45	4.72	8.80	13.5	36.8	61	132
	t _i	0.21 *	0.25 *	0.32	0.39	0.47	0.59	0.73	0.93	1.33	1.69	2.49
12	J_{2 Max}	0.64 *	1.04 *	1.82	2.75	4.42	6.8	11.9	19.8	45.2	73.4	158
	t _i	0.21 *	0.25 *	0.32	0.39	0.47	0.59	0.73	0.93	1.33	1.69	2.49
16	J_v	-	-	-	0.55	0.88	1.34	2.4	3.9	9.5	16.7	40.6
	t _i	-	-	-	0.19	0.23	0.29	0.35	0.45	0.64	0.81	1.20
20	J_v	-	-	-	0.69	1.11	1.86	3.01	5.26	11.95	20.9	50.7
	t _i	-	-	-	0.19	0.23	0.29	0.35	0.45	0.64	0.81	1.20
24	J_{2 Max}	-	-	-	0.83 *	1.33 *	2.24	3.61	6.3	14.35	25.1	60.90
	t _i	-	-	-	0.19 *	0.23 *	0.29	0.35	0.45	0.64	0.81	1.20

$J_{2 Max}$ = max admissible mass inertia loading (kgm²) t_i = cycle time (sec.) Depending on motor size, electronics and time optimisation settings, the cycle time measured from the start signal to the electric position indication is approx. 80 - 130 ms longer than the value specified in the table (see also the note on page 17).

*EF2 - Control recommended to minimise brake wear (see page 48).

DIMENSIONS

If you require subsequent drilling work on the indexing table, please request information on permissible drilling depths. The illustrated rotating plate position corresponds to the basic position of the rotary indexing table (Position when delivered).

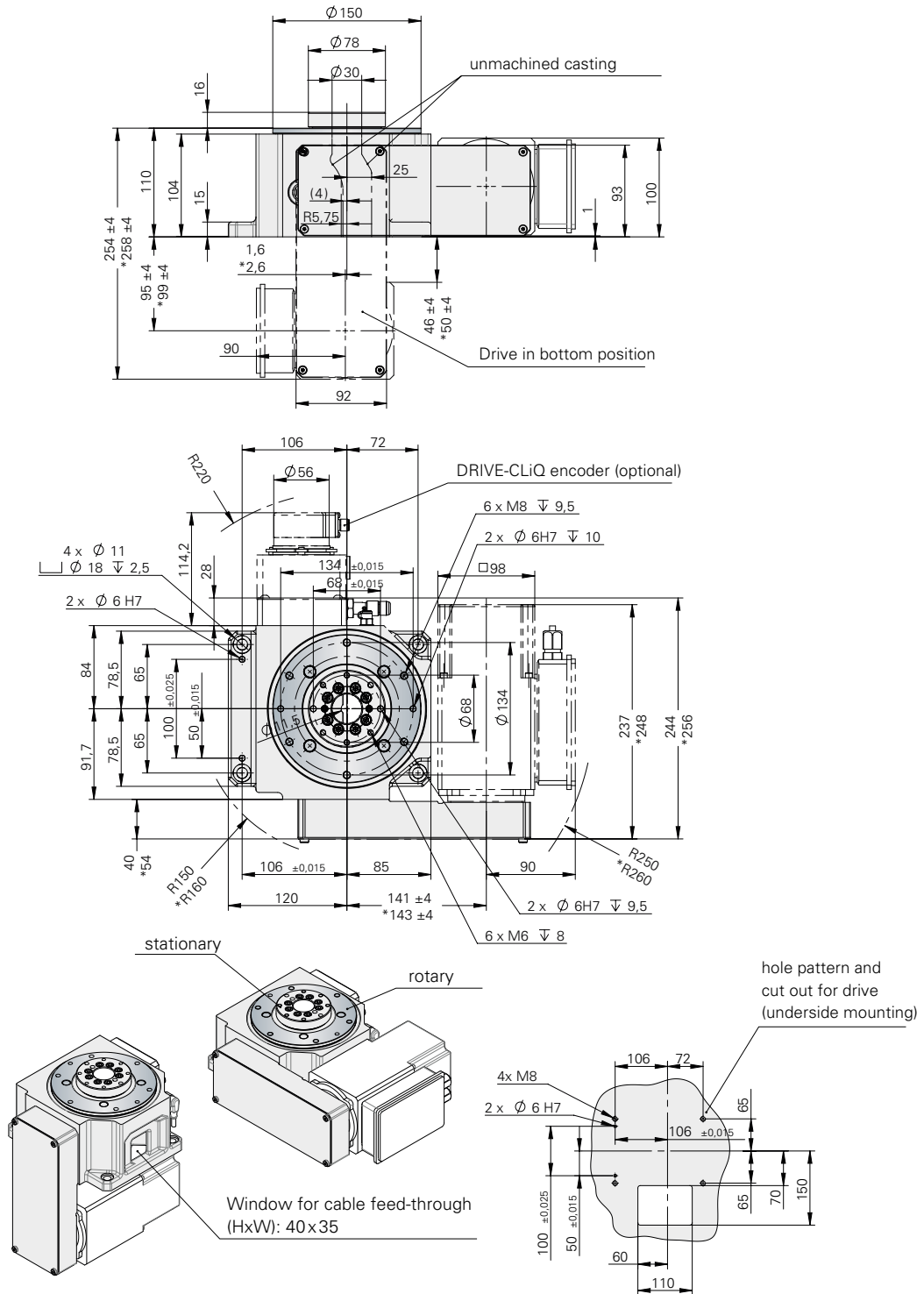

* Dimensions for speed levels: h, i, j (2-stage)

Max. centre line deviation between stationary centre section and dial: ± 180"

Max. centre line deviation between dial and indexer housing: ± 120"

Note: Please ensure motor and brake are accessible for servicing!

TC 220T



GENERAL INFORMATION

- Maximum recommended equipment diameter D_{tp} : approximately 1100 mm
- Custom option for TC0220T: screw-on mounting from above (please request drawing)

TECHNICAL DATA

U	Voltage (custom voltages available on request):	230 / 400 V
f	Frequency:	50 Hz
	Indexing precision*:	Indexing 2-12: 40 arcsec ($\pm 20''$) Indexing 16-24: 60 arcsec ($\pm 30''$) Indexing 30-36: 80 arcsec ($\pm 40''$)
A_r	Axial run-out of the drive flange:	(at $\varnothing 220$ mm) 0.01 mm
C_r	Concentricity of the output flange:	0.01 mm
P	Parallelism between the output flange and screw-on surface of the housing:	(at $\varnothing 220$ mm) 0.03 mm
m	Total weight, including motor:	44 kg
D_i	Min. inside diameter of the rotary plate:	96 mm

* Positioning accuracy can be improved by 10 arcsec on request.

LOAD DATA (for the stationary central part)

T_{SP}	Permitted torque:	145 Nm
M_{T SP}	Permitted tilting moment:	300 Nm
F_{A SP}	Permitted axial force:	5000 N
F_{R SP}	Permitted radial force:	4000 N

Combined loads and permitted process forces only after inspection by WEISS.

LOAD DATA (for the output flange)

T_{2 stat}	Static torque:	200 Nm
M_{2T dyn}	Permitted dynamic tilting moment:	700 Nm
F_{2A dyn}	Permitted dynamic axial force:	7500 N
F_{2R dyn}	Permitted dynamic radial force:	8000 N

LOAD TABLE 50 Hz (On request: higher loads / custom indexing and switching times for 60 hz mains frequency)

Indexing	Speed level												2-stage			Using the BG 71 motor					
		b	c	d	e	f	g	h	i	j	k	l	m	n	o	b	c	d	e	f	g
2	J_{2 Max}	-	-	0.15	0.36	0.58	0.76	1.3	2.02	3.55	9.6	13.30	35.6	96	167	-	-	-	-	-	-
	t _i	-	-	0.35	0.50	0.60	0.67	0.84	1.02	1.30	1.99	2.30	3.53	5.42	6.91	-	-	-	-	-	-
3	J_{2 Max}	-	0.18*	0.3	0.69	1.09	1.43	2.41	3.73	6.54	17.65	24.55	65.5	176	308	-	-	-	-	-	-
	t _i	-	0.29*	0.35	0.50	0.60	0.67	0.84	1.02	1.30	1.99	2.30	3.53	5.42	6.91	-	-	-	-	-	-
4	J_{2 Max}	0.12*	0.24*	0.46	1.34	2.38	3.36	6.6	11.6	17.3	31.5	48.5	144	340	552	0.19*	0.37*	0.69	1.97	3.5	4.61
	t _i	0.22*	0.26*	0.32	0.45	0.54	0.61	0.76	0.92	1.17	1.80	2.07	3.17	4.88	6.22	0.22*	0.26*	0.32	0.45	0.54	0.61
6	J_{2 Max}	0.31*	0.58*	1.06	3.05	5.4	7.6	14.9	24.9	26	70.9	109	324	765	1240	0.48*	0.87*	1.59	4.53	7.45	-
	t _i	0.22*	0.26*	0.32	0.45	0.54	0.61	0.76	0.92	1.17	1.80	2.07	3.17	4.88	6.22	0.22*	0.26*	0.32	0.45	0.54	-
8	J_{2 Max}	0.58*	1.06*	1.92	5.44	9.63	13.55	19.05	33.5	46.2	126	195	495	1170	1900	0.87*	1.58*	2.85	6.92	10.7	-
	t _i	0.22*	0.26*	0.32	0.45	0.54	0.61	0.76	0.92	1.17	1.80	2.07	3.17	4.88	6.22	0.22*	0.26*	0.32	0.45	0.54	-
10	J_{2 Max}	0.92*	1.67*	3.01	8.48	14.55	18.88	29.8	48.7	72	192	257	600	1420	2300	1.37*	2.48*	4.24	9.4	-	-
	t _i	0.22*	0.26*	0.32	0.45	0.54	0.61	0.76	0.92	1.17	1.80	2.07	3.17	4.88	6.22	0.22*	0.26*	0.32	0.45	-	-
12	J_{2 Max}	1.34*	2.41*	4.35	10.7	16	20.1	31.5	45.9	74.6	176.4	235.2	551	1300	2110	1.96*	3.08*	-	-	-	-
	t _i	0.22*	0.26*	0.32	0.45	0.54	0.61	0.76	0.92	1.17	1.80	2.07	3.17	4.88	6.22	0.22*	0.26*	-	-	-	-
16	J_v	-	-	-	2*	3.1*	4.03	6.74	9.95	18.2	49.1	68.30	182	490	855	-	-	-	-	-	-
	t _i	-	-	-	0.22*	0.26*	0.29	0.37	0.44	0.56	0.86	1.00	1.53	2.35	2.99	-	-	-	-	-	-
20	J_v	-	-	-	3.05*	4.72*	6.14	10.2	15.6	27.7	68.1	90.9	213	500	815	-	-	-	-	-	-
	t _i	-	-	-	0.22*	0.26*	0.29	0.37	0.44	0.56	0.86	1.00	1.53	2.35	2.99	-	-	-	-	-	-
24	J_v	-	-	-	3.67*	5.68*	7.38*	12.35	19	33.3	81.7	109	255	600	980	-	-	-	-	-	-
	t _i	-	-	-	0.22*	0.26*	0.29*	0.37	0.44	0.56	0.86	1.00	1.53	2.35	2.99	-	-	-	-	-	-
30	J_v	-	-	-	-	-	3.59*	6.01*	9.29*	16.2	43.7	60.9	162	420	680	-	-	-	-	-	-
	t _i	-	-	-	-	-	0.19*	0.24*	0.29*	0.37	0.57	0.65	1.00	1.54	1.96	-	-	-	-	-	-
36	J_{2 Max}	-	-	-	-	-	4.32*	7.23*	11.15*	19.5	52	69.5	163	385	625	-	-	-	-	-	-
	t _i	-	-	-	-	-	0.19*	0.24*	0.29*	0.37	0.57	0.65	1.00	1.54	1.96	-	-	-	-	-	-

J_{2 Max} = max admissible mass inertia loading (kgm²) **t_i** = cycle time (sec.) Depending on motor size, electronics and time optimisation settings, the cycle time measured from the start signal to the electric position indication is approx. 80 - 130 ms longer than the value specified in the table. (see also the note on page 17).

***EF2** - Control recommended to minimise brake wear (see page 48).

The values in the second table apply for the maximum permitted mass moment of inertia when using the size 71 motor.

DIMENSIONS

If you require subsequent drilling work on the indexing table, please request information on permissible drilling depths. The illustrated rotating plate position corresponds to the basic position of the rotary indexing table (Position when delivered).

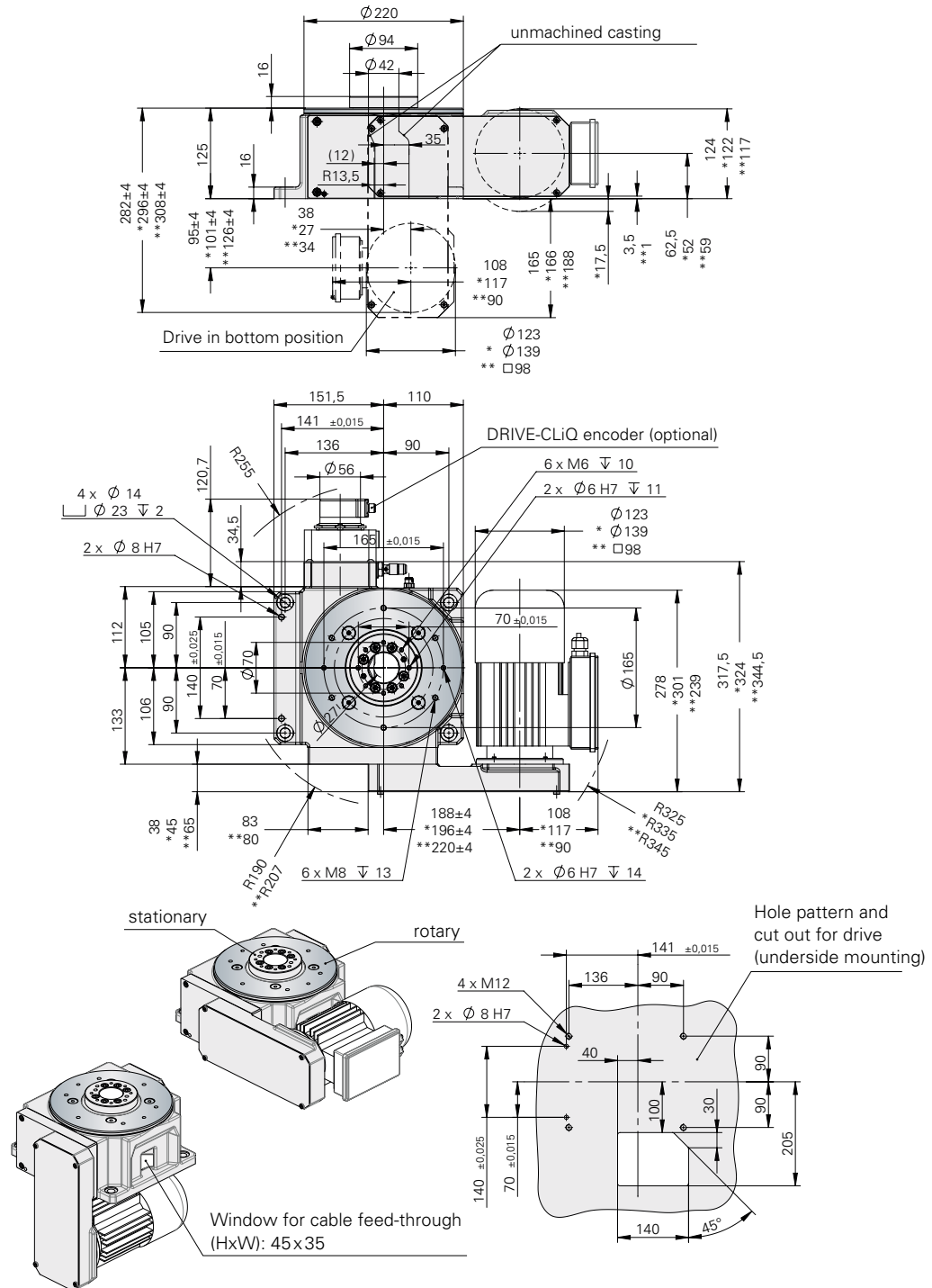

* Dimensions for motor BG71
 ** Dimensions for speed levels: m, n, o (2-stage)

Max. centre line deviation between stationary centre section and dial: ± 150"
 Max. centre line deviation between dial and indexer housing: ± 100"

Note: Please ensure motor and brake are accessible for servicing!

TC 320T



GENERAL INFORMATION

- Maximum recommended equipment diameter D_{tp} : approximately 1400 mm
- Custom option for TC0320T: screw-on mounting from above (please request drawing)

TECHNICAL DATA

U	Voltage (custom voltages available on request):	230 / 400 V
f	Frequency:	50 Hz
	Indexing precision*:	Indexing 2-12: 40 arcsec ($\pm 20''$) Indexing 16-24: 60 arcsec ($\pm 30''$) Indexing 30-36: 70 arcsec ($\pm 35''$)
A_r	Axial run-out of the drive flange:	(at \emptyset 320 mm) 0.01 mm
C_r	Concentricity of the output flange:	0.01 mm
P	Parallelism between the output flange and screw-on surface of the housing:	(at \emptyset 320 mm) 0.03 mm
m	Total weight, including motor:	112 kg
D_i	Min. inside diameter of the rotary plate:	150 mm

* Positioning accuracy can be improved by 10 arcsec on request.

LOAD DATA (for the stationary central part)

T_{SP}	Permitted torque:	800 Nm
M_{T SP}	Permitted tilting moment:	1800 Nm
F_{A SP}	Permitted axial force:	18000 N
F_{R SP}	Permitted radial force:	10000 N

Combined loads and permitted process forces only after inspection by WEISS.

LOAD DATA (for the output flange)

T_{2 stat}	Static torque:	600 Nm
M_{2T dyn}	Permitted dynamic tilting moment:	2250 Nm
F_{2A dyn}	Permitted dynamic axial force:	15000 N
F_{2R dyn}	Permitted dynamic radial force:	13000 N

LOAD TABLE 50 Hz (On request: higher loads / custom indexing and switching times for 60 hz mains frequency)

Indexing	Speed level																	2-stage		
		s	a	b	c	d	e	f	g	h	i	j	k	l	m	n	o	p	q	
2	J_{2 Max}	-	-	-	-	-	2.67	3.51	4.3	6.27	9.79	18	27.3	36.6	72	95.5	106	143	214	
	t _i	-	-	-	-	-	0.61	0.69	0.75	0.89	1.06	1.37	1.64	2.07	2.64	3.04	3.3	3.72	4.55	
3	J_{2 Max}	-	-	-	-	3.15	4.26	5.58	6.81	10.3	15.3	28.1	42.6	72.8	127	175	212	280	446	
	t _i	-	-	-	-	0.54	0.61	0.69	0.75	0.89	1.06	1.37	1.64	2.07	2.64	3.04	3.3	3.72	4.55	
4	J_{2 Max}	1.62 *	2.95 *	4.59	5.6	7.33	9.83	11.8	15.2	23.4	31.8	58.1	83.4	109	215	285	318	427	640	
	t _i	0.3 *	0.36 *	0.42	0.45	0.51	0.57	0.64	0.7	0.83	0.99	1.28	1.53	1.93	2.46	2.83	3.08	3.47	4.25	
6	J_{2 Max}	3.9 *	6.89 *	9.57	11.6	15.1	20.2	26.2	31.9	48	71.1	129	187	246	485	641	716	961	1440	
	t _i	0.3 *	0.36 *	0.42	0.45	0.51	0.57	0.64	0.7	0.83	0.99	1.28	1.53	1.93	2.46	2.83	3.08	3.47	4.25	
8	J_{2 Max}	7.1 *	12.4 *	18.97	24.2	31.4	42	54.4	66.1	98.4	128	233	334	439	862	1140	1270	1700	2560	
	t _i	0.3 *	0.36 *	0.42	0.45	0.51	0.57	0.64	0.7	0.83	0.99	1.28	1.53	1.93	2.46	2.83	3.08	3.47	4.25	
10	J_{2 Max}	10 *	17.19 *	23.7	28.8	37.5	50	64.8	78.7	118	174	318	456	615	1170	1550	1780	2330	3500	
	t _i	0.29 *	0.35 *	0.4	0.44	0.49	0.55	0.62	0.67	0.8	0.95	1.24	1.48	1.87	2.38	2.73	2.97	3.35	4.1	
12	J_{2 Max}	13.5 *	20.7 *	28.6	34.7	45.1	60.1	77.9	94.7	142	210	382	547	871	1410	1860	2200	2800	4200	
	t _i	0.29 *	0.35 *	0.4	0.44	0.49	0.55	0.62	0.67	0.8	0.95	1.24	1.48	1.87	2.38	2.73	2.97	3.35	4.1	
16	J_v	-	-	-	-	8.15 *	10.9 *	14.2	17.2	26	38.5	70.4	105	138	271	359	400	538	806	
	t _i	-	-	-	-	0.22 *	0.25 *	0.28	0.3	0.36	0.42	0.55	0.66	0.83	1.06	1.21	1.32	1.49	1.82	
20	J_v	-	-	-	-	12.29 *	16.4 *	21.3	25.9	37.7	57.7	105	159	215	424	561	626	841	1260	
	t _i	-	-	-	-	0.22 *	0.25 *	0.28	0.3	0.36	0.42	0.55	0.66	0.83	1.06	1.21	1.32	1.49	1.82	
24	J_v	-	-	-	-	-	17.24 *	22.3	27.2	40.9	60.5	110	167	285	498	686	872	1100	1650	
	t _i	-	-	-	-	-	0.25 *	0.28	0.3	0.36	0.42	0.55	0.66	0.83	1.06	1.21	1.32	1.49	1.82	
30	J_v	-	-	-	-	-	-	-	14.16 *	21.3 *	31.6	57.7	87.5	143	260	359	418	560	840	
	t _i	-	-	-	-	-	-	-	0.2 *	0.24 *	0.28	0.37	0.44	0.55	0.7	0.81	0.88	0.99	1.21	
36	J_{2 Max}	-	-	-	-	-	-	-	17.03 *	25.6 *	37.9	69.3	103	179	308	431	581	738	1100	
	t _i	-	-	-	-	-	-	-	0.2 *	0.24 *	0.28	0.37	0.44	0.55	0.7	0.81	0.88	0.99	1.21	

J_{2 Max} = max admissible mass inertia loading (kgm²) **t_i** = cycle time (sec.) Depending on motor size, electronics and time optimisation settings, the cycle time measured from the start signal to the electric position indication is approx. 80 - 130 ms longer than the value specified in the table (see also the note on page 17).

*EF2 - Control recommended to minimise brake wear (see page 48).

DIMENSIONS

If you require subsequent drilling work on the indexing table, please request information on permissible drilling depths. The illustrated rotating plate position corresponds to the basic position of the rotary indexing table (Position when delivered).

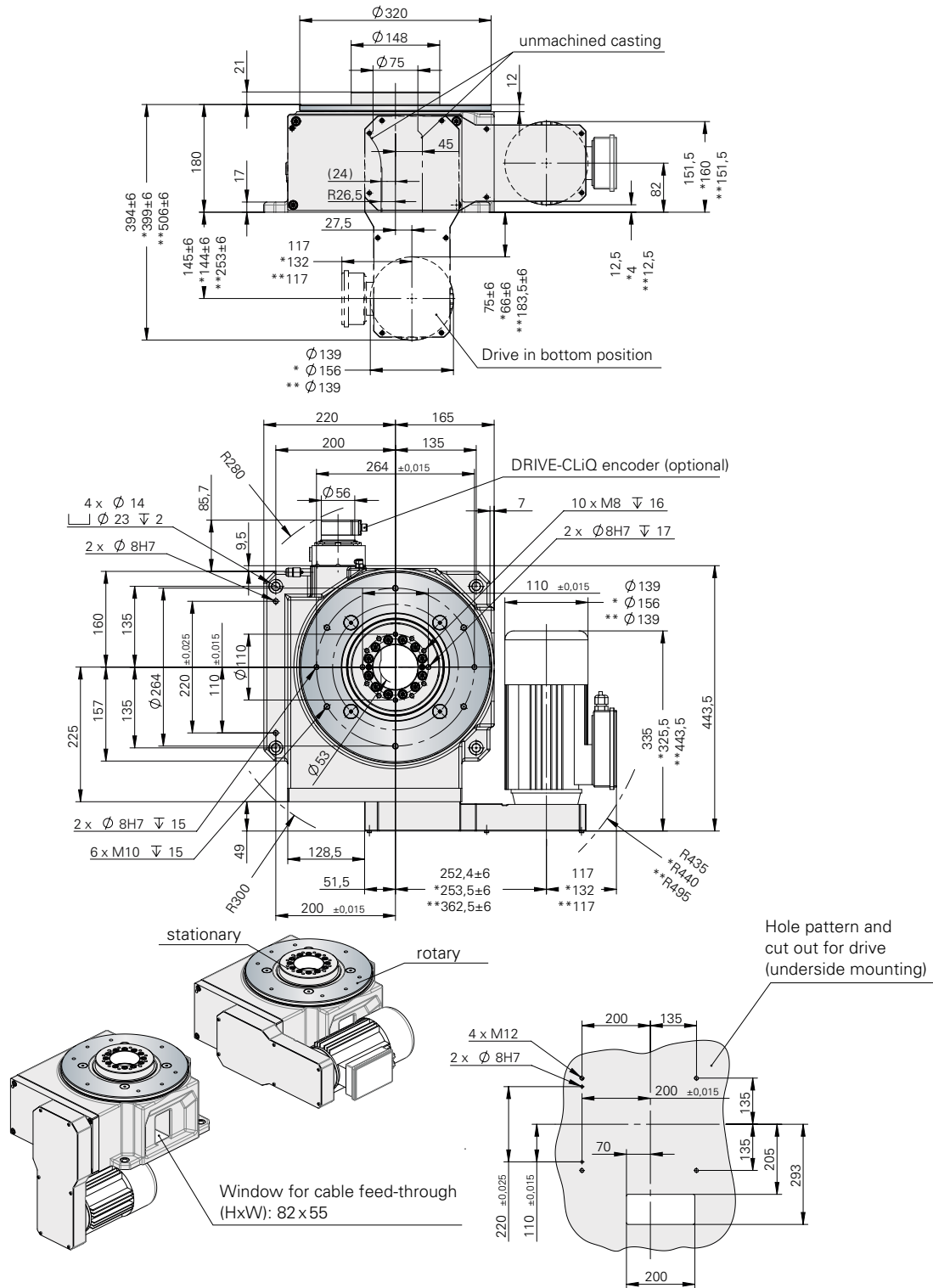

- * Dimensions for motor BG80
- ** Dimensions for speed levels: o, p, q (2-stage)

Max. centre line deviation between stationary centre section and dial: ± 130"
 Max. centre line deviation between dial and indexer housing: ± 80"

Note: Please ensure motor and brake are accessible for servicing!

TC 500T



GENERAL INFORMATION

· Maximum recommended equipment diameter D_{tp} : approximately 2000 mm

TECHNICAL DATA

U	Voltage (custom voltages available on request):	230 / 400 V
f	Frequency:	50 Hz
	Indexing precision*:	Indexing 2-12: 30 arcsec ($\pm 15''$) Indexing 16-48: 40 arcsec ($\pm 20''$)
A_r	Axial run-out of the drive flange:	(at \varnothing 500 mm) 0.015 mm
C_r	Concentricity of the output flange:	0.015 mm
P	Parallelism between the output flange and screw-on surface of the housing:	(at \varnothing 500 mm) 0.03 mm
m	Total weight, including motor:	305 kg
D_i	Min. inside diameter of the rotary plate:	242 mm

* Positioning accuracy can be improved by 10 arcsec on request.

LOAD DATA (for the stationary central part)

T_{SP}	Permitted torque:	800 Nm
M_{T SP}	Permitted tilting moment:	2500 Nm
F_{A SP}	Permitted axial force:	25000 N
F_{R SP}	Permitted radial force:	15000 N

Combined loads and permitted process forces only after inspection by WEISS.

LOAD DATA (for the output flange)

T_{2 stat}	Static torque:	1000 Nm
M_{2T dyn}	Permitted dynamic tilting moment:	6000 Nm
F_{2A dyn}	Permitted dynamic axial force:	25000 N
F_{2R dyn}	Permitted dynamic radial force:	20000 N

LOAD TABLE 50 Hz (On request: higher loads / custom indexing and switching times for 60 hz mains frequency)

Indexing	Speed level																2-stage		
		s	a	b	c	d	e	f	g	h	i	j	k	l	m	n	o	p	q
2	J_{2 Max}	-	-	-	6.2	9.3	12	18	24.3	36.4	55.6	100	172	233	274	474	805	1010	1650
	t _i	-	-	-	0.68	0.79	0.87	1.02	1.16	1.36	1.66	2.10	2.67	3.02	3.26	4.28	5.80	6.26	8.23
3	J_{2 Max}	-	-	-	7.8	11.5	14.9	22.1	29.7	44.2	70.7	121	213	282	337	634	1270	1520	2850
	t _i	-	-	-	0.68	0.79	0.87	1.02	1.16	1.36	1.66	2.10	2.67	3.02	3.26	4.28	5.80	6.26	8.23
4	J_{2 Max}	-	7.1 *	10.6	18	25.9	32.9	48.1	64	94.6	150	257	450	595	710	1260	2150	2710	4430
	t _i	-	0.43*	0.50	0.61	0.71	0.79	0.92	1.04	1.23	1.50	1.89	2.41	2.72	2.93	3.85	5.22	5.64	7.40
6	J_{2 Max}	10.2*	14.7*	22.20	35.9	51.1	64.4	93.5	124	182	289	493	862	1140	1360	2550	4840	6100	9980
	t _i	0.37*	0.43*	0.50	0.61	0.71	0.79	0.92	1.04	1.23	1.50	1.89	2.41	2.72	2.93	3.85	5.22	5.64	7.40
8	J_{2 Max}	23.8*	34.2*	49	79.5	112	140	204	270	397	628	1070	1850	2350	2740	4740	8620	10100	17500
	t _i	0.37*	0.43*	0.50	0.61	0.71	0.79	0.92	1.04	1.23	1.50	1.89	2.41	2.72	2.93	3.85	5.22	5.64	7.40
10	J_{2 Max}	30.2*	43.1*	61.5	99.7	140	177	255	338	497	785	1330	2330	2980	3480	6010	11000	12800	22000
	t _i	0.37*	0.43*	0.50	0.61	0.71	0.79	0.92	1.04	1.23	1.50	1.89	2.41	2.72	2.93	3.85	5.22	5.64	7.40
12	J_{2 Max}	36.5*	52 *	73.3	120	169	212	307	406	595	941	1600	2800	3580	4180	7210	13200	15400	26600
	t _i	0.37*	0.43*	0.50	0.61	0.71	0.79	0.92	1.04	1.23	1.50	1.89	2.41	2.72	2.93	3.85	5.22	5.64	7.40
16	J_v	-	-	11.7*	19.8*	28.4	36	52.6	70	103	164	280	490	629	775	1450	2920	3480	6230
	t _i	-	-	0.22*	0.27*	0.32	0.35	0.41	0.46	0.55	0.67	0.84	1.07	1.21	1.30	1.71	2.32	2.50	3.29
20	J_v	-	-	-	31.8*	45.3	57.2	83.1	110	162	257	439	768	1010	1210	2270	4340	5060	8750
	t _i	-	-	-	0.27*	0.32	0.35	0.41	0.46	0.55	0.67	0.84	1.07	1.21	1.30	1.71	2.32	2.50	3.29
24	J_v	-	-	-	38.5*	54.7	68.2	100	132	193	309	528	923	1220	1450	2700	5200	6080	10500
	t _i	-	-	-	0.27*	0.32	0.35	0.41	0.46	0.55	0.67	0.84	1.07	1.21	1.30	1.71	2.32	2.50	3.29
30	J_v	-	-	-	-	-	34.9*	50.9*	67.8	100	158	271	455	629	751	1400	2820	3370	5830
	t _i	-	-	-	-	-	0.23*	0.27*	0.31	0.36	0.44	0.56	0.71	0.80	0.87	1.14	1.55	1.67	2.19
36	J_{2 Max}	-	-	-	-	-	34.2*	49.8*	66.4	98.1	155	266	466	616	736	1350	2470	2880	4950
	t _i	-	-	-	-	-	0.23*	0.27*	0.31	0.36	0.44	0.56	0.71	0.80	0.87	1.14	1.55	1.67	2.19
48	J_{2 Max}	-	-	-	-	-	46.2*	67.1*	89.3	131	208	356	623	824	984	1800	3300	3850	6650
	t _i	-	-	-	-	-	0.23*	0.27*	0.31	0.36	0.44	0.56	0.71	0.80	0.87	1.14	1.55	1.67	2.19

J_{2 Max} = max admissible mass inertia loading (kgm²) **t_i** = cycle time (sec.) Depending on motor size, electronics and time optimisation settings, the cycle time measured from the start signal to the electric position indication is approx. 80 - 130 ms longer than the value specified in the table (see also the note on page 17).

*EF2 - Control recommended to minimise brake wear (see page 48).

DIMENSIONS

If you require subsequent drilling work on the indexing table, please request information on permissible drilling depths. The illustrated rotating plate position corresponds to the basic position of the rotary indexing table (Position when delivered).

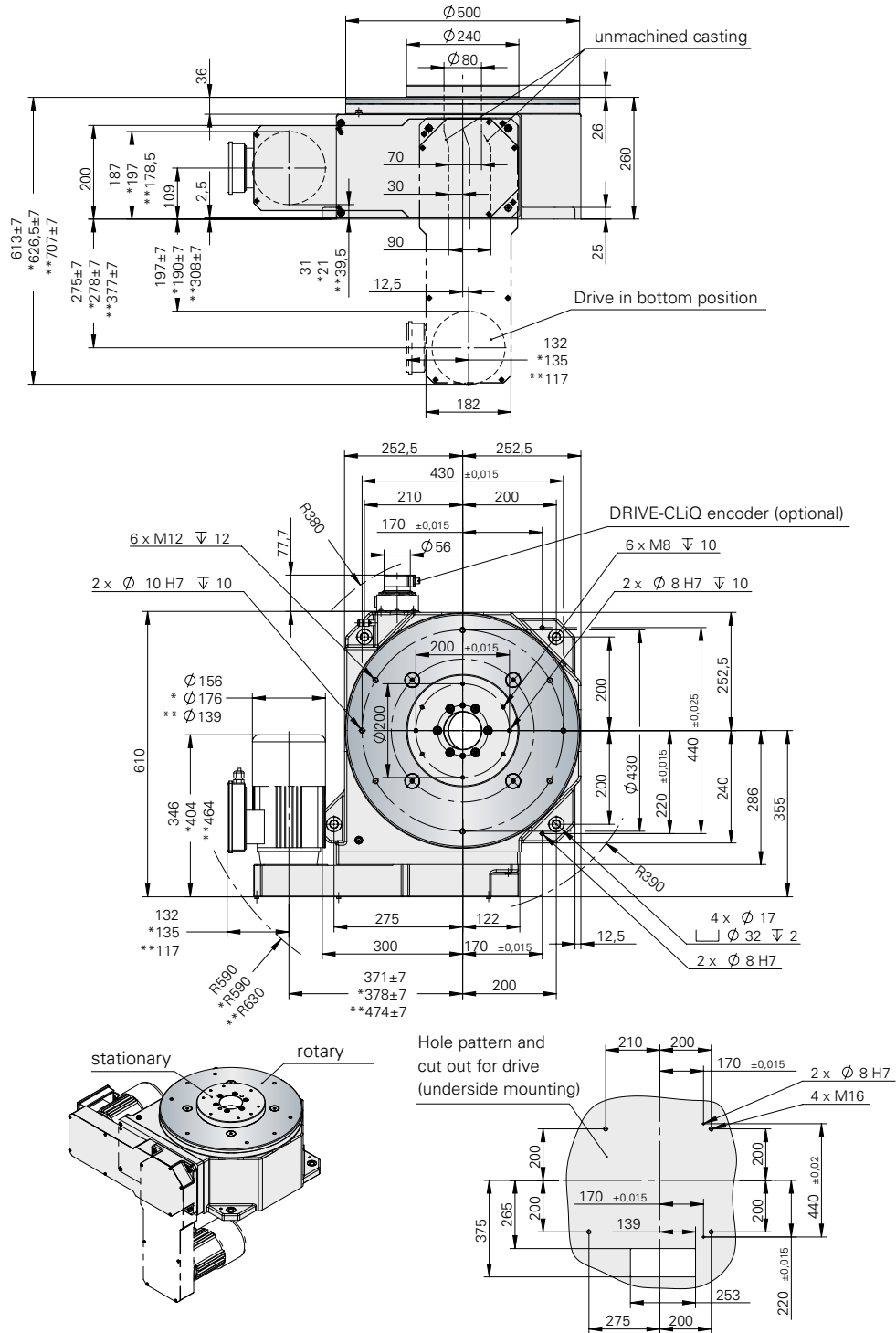

- * Dimensions for motor BG90
- ** Dimensions for speed levels: o, p, q (2-stage)

Max. centre line deviation between stationary centre section and dial: ± 75"
 Max. centre line deviation between dial and indexer housing: ± 55"

Note: Please ensure motor and brake are accessible for servicing!

TC 700T



GENERAL INFORMATION

· Maximum recommended equipment diameter D_{tp} : approximately 3000 mm

TECHNICAL DATA

U	Voltage (custom voltages available on request):	230 / 400 V
f	Frequency:	50 Hz
	Indexing precision*:	Indexing 2-12: 24 arcsec ($\pm 12''$) Indexing 16-60: 32 arcsec ($\pm 16''$)
A_r	Axial run-out of the drive flange:	(at \varnothing 700 mm) 0.02 mm
C_r	Concentricity of the output flange:	0.02 mm
P	Parallelism between the output flange and screw-on surface of the housing:	(at \varnothing 700 mm) 0.03 mm
m	Total weight, including motor:	660 kg
D_i	Min. inside diameter of the rotary plate:	242 mm

* Positioning accuracy can be improved by 10 arcsec on request.

LOAD DATA (for the stationary central part)

T_{SP}	Permitted torque:	1000 Nm
M_{T SP}	Permitted tilting moment:	3000 Nm
F_{A SP}	Permitted axial force:	30000 N
F_{R SP}	Permitted radial force:	15000 N

Combined loads and permitted process forces only after inspection by WEISS.

LOAD DATA (for the output flange)

T_{2 stat}	Static torque:	1400 Nm
M_{2T dyn}	Permitted dynamic tilting moment:	10000 Nm
F_{2A dyn}	Permitted dynamic axial force:	40000 N
F_{2R dyn}	Permitted dynamic radial force:	27000 N

LOAD TABLE 50 Hz (On request: higher loads / custom indexing and switching times for 60 hz mains frequency)

Indexing	Speed level													2-stage		
		s	a	b	c	d	e	f	g	h	i	j	k	l	m	n
2	J_{2 Max}	-	9	19	37	56.7	104	149	213	335	587	1010	1650	2920	4650	6700
	t _i	-	0.69	0.81	0.98	1.14	1.46	1.69	1.96	2.40	3.01	3.84	4.70	6.18	7.37	9.04
3	J_{2 Max}	-	24	37.6	62.4	93.4	165	239	340	547	927	1620	2590	4850	7320	11700
	t _i	-	0.69	0.81	0.98	1.14	1.46	1.69	1.96	2.40	3.01	3.84	4.70	6.18	7.37	9.04
4	J_{max}	20	36	62	115	169	294	424	601	909	1630	2730	4550	7800	12500	17900
	t _s	0.53	0.62	0.73	0.88	1.03	1.31	1.52	1.76	2.16	2.71	3.45	4.23	5.56	6.64	8.13
6	J_{max}	53	90	149	233	342	604	845	1190	1910	3230	5640	9020	16900	25300	40300
	t _s	0.53	0.62	0.73	0.88	1.03	1.31	1.52	1.76	2.16	2.71	3.45	4.23	5.56	6.64	8.13
8	J_{max}	101	166	270	484	702	1200	1720	2430	3650	6560	10900	18300	31200	48800	71500
	t _s	0.53	0.62	0.73	0.88	1.03	1.31	1.52	1.76	2.16	2.71	3.45	4.23	5.56	6.64	8.13
10	J_{max}	161	263	412	641	900	1630	2280	3220	5150	8670	15100	24200	41800	59500	89500
	t _s	0.53	0.62	0.73	0.88	1.03	1.31	1.52	1.76	2.16	2.71	3.45	4.23	5.56	6.64	8.13
12	J_{max}	236	360	518	803	1170	2050	2850	4040	6460	10900	19000	29100	50200	71500	107000
	t _s	0.53	0.62	0.73	0.88	1.03	1.31	1.52	1.76	2.16	2.71	3.45	4.23	5.56	6.64	8.13
16	J_v	-	-	-	-	195	346	486	688	1100	1850	3250	5210	9760	14600	23400
	t _i	-	-	-	-	0.46	0.58	0.67	0.78	0.96	1.20	1.53	1.88	2.47	2.95	3.62
20	J_v	-	-	-	-	302	533	747	1050	1690	2850	4980	7960	14900	22400	35400
	t _i	-	-	-	-	0.46	0.58	0.67	0.78	0.96	1.20	1.53	1.88	2.47	2.95	3.62
24	J_v	-	-	-	-	364	642	898	1270	2030	3430	5990	9570	17900	26800	42400
	t _i	-	-	-	-	0.46	0.58	0.67	0.78	0.96	1.20	1.53	1.88	2.47	2.95	3.62
30	J_v	-	-	-	-	179	252	356	577	978	1710	2740	5130	7710	12300	
	t _i	-	-	-	-	0.39	0.45	0.52	0.64	0.80	1.02	1.25	1.65	1.97	2.41	
36	J_{2 Max}	-	-	-	-	216	304	432	694	1170	2040	3280	6160	9250	14700	
	t _i	-	-	-	-	0.39	0.45	0.52	0.64	0.80	1.02	1.25	1.65	1.97	2.41	
48	J_{2 Max}	-	-	-	-	291	408	579	930	1570	2740	4390	8240	12300	19700	
	t _i	-	-	-	-	0.39	0.45	0.52	0.64	0.80	1.02	1.25	1.65	1.97	2.41	
60	J_{2 Max}	-	-	-	-	250	351	498	800	1350	2360	3780	7100	10600	17000	
	t _i	-	-	-	-	0.39	0.45	0.52	0.64	0.80	1.02	1.25	1.65	1.97	2.41	

J_{2 Max} = max admissible mass inertia loading (kgm²) **t_i** = cycle time (sec.) Depending on motor size, electronics and time optimisation settings, the cycle time measured from the start signal to the electric position indication is approx. 80 - 130 ms longer than the value specified in the table.

EF2 - Control recommended to minimise brake wear (see page 48).

DIMENSIONS

If you require subsequent drilling work on the indexing table, please request information on permissible drilling depths. The illustrated rotating plate position corresponds to the basic position of the rotary indexing table (Position when delivered).

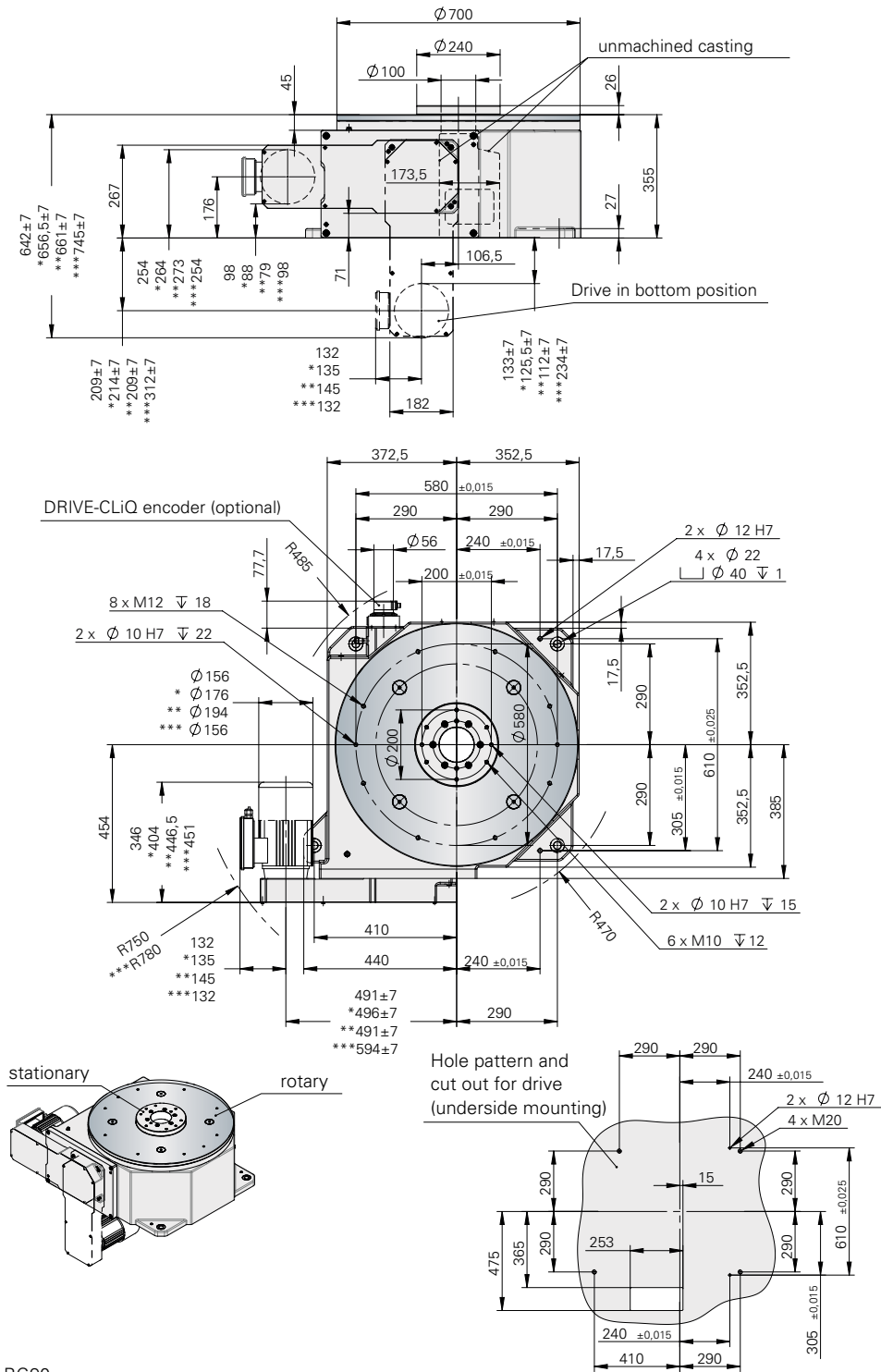

- * Dimensions for motor BG90
- ** Dimensions for motor BG100
- *** Dimensions for speed levels: m, n (2-stage)

Max. centre line deviation between stationary centre section and dial: ± 60"

Max. centre line deviation between dial and indexer housing: ± 40"

Note: Please ensure motor and brake are accessible for servicing!

TC 1000T



GENERAL INFORMATION

· Maximum recommended equipment diameter D_{tp} : approximately 5000 mm

TECHNICAL DATA

U	Voltage (custom voltages available on request):	230 / 400 V
f	Frequency:	50 Hz
	Indexing precision*:	Indexing 2-20: 24 arcsec ($\pm 12''$) Indexing 24-36: 32 arcsec ($\pm 16''$)
A_r	Axial run-out of the drive flange:	(at \varnothing 1000 mm) 0.03 mm
C_r	Concentricity of the output flange:	0.03 mm
P	Parallelism between the output flange and screw-on surface of the housing:	(at \varnothing 1000 mm) 0.05 mm
m	Total weight, including motor:	1530 kg
D_i	Min. inside diameter of the rotary plate:	522 mm

* Positioning accuracy can be improved by 10 arcsec on request.

LOAD DATA (for the stationary central part)

T_{SP}	Permitted torque:	1800 Nm
M_{T SP}	Permitted tilting moment:	5000 Nm
F_{A SP}	Permitted axial force:	40000 N
F_{R SP}	Permitted radial force:	17000 N

Combined loads and permitted process forces only after inspection by WEISS.

LOAD DATA (for the output flange)

T_{2 stat}	Static torque:	2200 Nm
M_{2T dyn}	Permitted dynamic tilting moment:	13000 Nm
F_{2A dyn}	Permitted dynamic axial force:	80000 N
F_{2R dyn}	Permitted dynamic radial force:	45000 N

LOAD TABLE 50 Hz (On request: higher loads / custom indexing and switching times for 60 hz mains frequency)

Indexing	Speed level	2-stage									
		a	b	c	d	e	f	g	h	i	j
2	J_{2 Max}	108	173	333	695	1130	1930	2820	4910	14900	19700
	t _i	1.28	1.50	1.92	2.57	3.15	3.96	5.04	6.18	10.74	12.33
3	J_{2 Max}	182	280	521	1060	1720	2920	4670	8230	29400	40500
	t _i	1.28	1.50	1.92	2.57	3.15	3.96	5.04	6.18	10.74	12.33
4	J_{2 Max}	406	604	1080	1990	3410	5370	7600	13200	39900	52700
	t _i	1.15	1.35	1.73	2.32	2.84	3.56	4.54	5.56	9.67	11.10
6	J_{2 Max}	807	1180	2100	4170	6680	11200	17100	29700	89900	118000
	t _i	1.15	1.35	1.73	2.32	2.84	3.56	4.54	5.56	9.67	11.10
8	J_{2 Max}	1710	2480	4380	8080	13700	21600	30500	52900	160000	210000
	t _i	1.15	1.35	1.73	2.32	2.84	3.56	4.54	5.56	9.67	11.10
10	J_{2 Max}	2147	3110	5480	10800	17300	28100	35000	64400	207000	273000
	t _i	1.15	1.35	1.73	2.32	2.84	3.56	4.54	5.56	9.67	11.10
12	J_{2 Max}	2585	3750	6590	13000	20800	33700	54800	82400	249000	328000
	t _i	1.15	1.35	1.73	2.32	2.84	3.56	4.54	5.56	9.67	11.10
16	J_v	3459	5010	8800	17300	27700	45000	73000	109000	332000	437000
	t _i	1.15	1.35	1.73	2.32	2.84	3.56	4.54	5.56	9.67	11.10
24	J_v	730	1070	1900	3780	6070	10200	17600	28600	98400	129000
	t _i	0.51	0.60	0.77	1.03	1.26	1.58	2.02	2.47	4.30	4.93
36	J_{2 Max}	-	-	1109	2220	3570	6040	10500	16900	60400	83000
	t _i	-	-	0.51	0.69	0.84	1.06	1.34	1.65	2.86	3.29

J_{2 Max} = max admissible mass inertia loading (kgm²) **t_i** = cycle time (sec.) Depending on motor size, electronics and time optimisation settings, the cycle time measured from the start signal to the electric position indication is approx. 80 - 130 ms longer than the value specified in the table.

EF2 - Control recommended to minimise brake wear (see page 48).

DIMENSIONS

If you require subsequent drilling work on the indexing table, please request information on permissible drilling depths. The illustrated rotating plate position corresponds to the basic position of the rotary indexing table (Position when delivered).

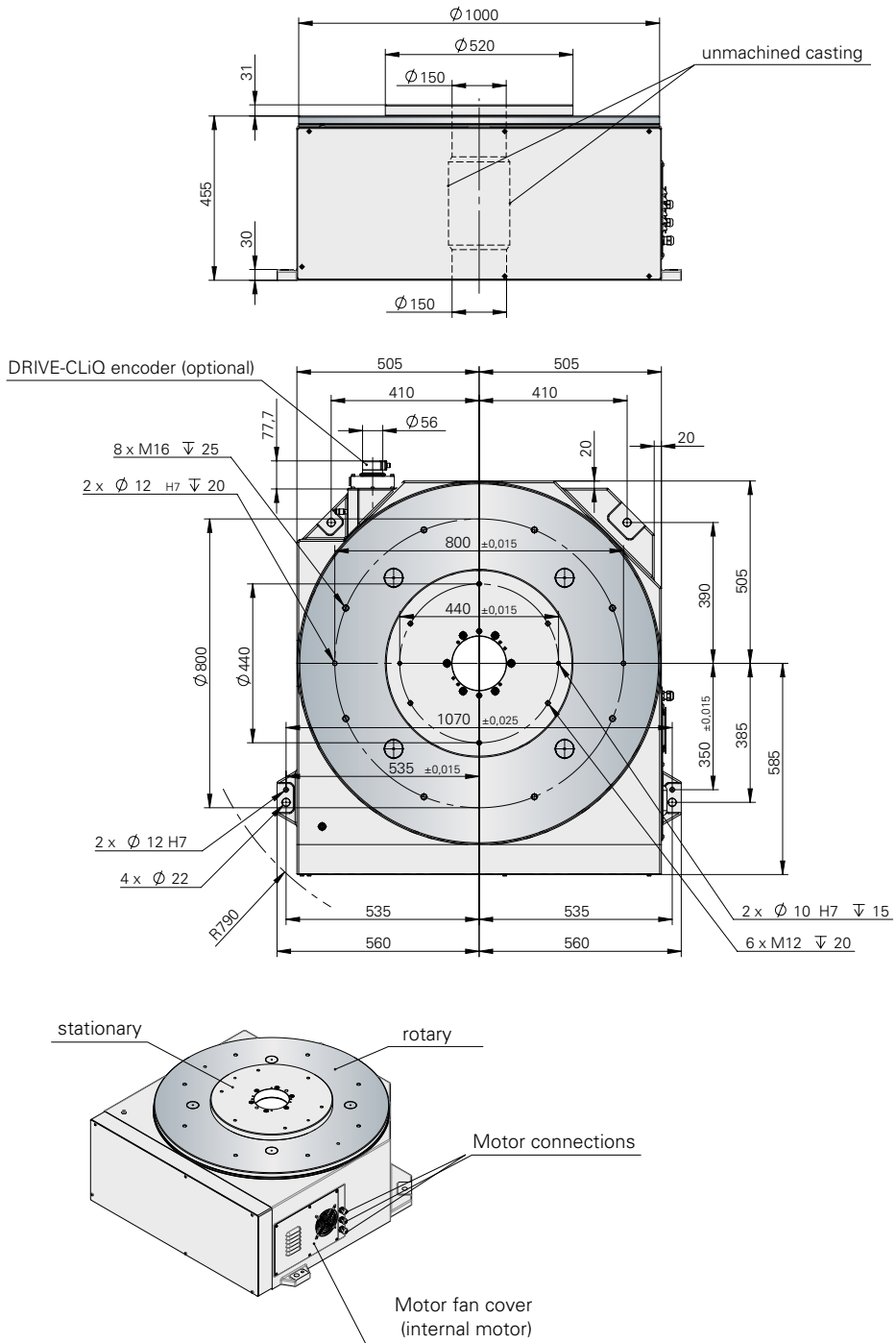

* Dimensions for speed levels: h, i, j (2-stage)

Max. centre line deviation between stationary centre section and dial: $\pm 45''$

Max. centre line deviation between dial and indexer housing: $\pm 35''$

Note: Please ensure motor and brake are accessible for servicing!

ROTARY PLATE



We manufacture rotary plates to your specifications from steel, aluminium or high-strength aluminium. Particularly when working with aluminium plates (material AlMg4,5Mn F28), we pay

attention to ensuring that the material is free of tension. If desired, the aluminium plates can also be anodised (natural or colour). Steel plates are chemically nickel-plated.

CALCULATION

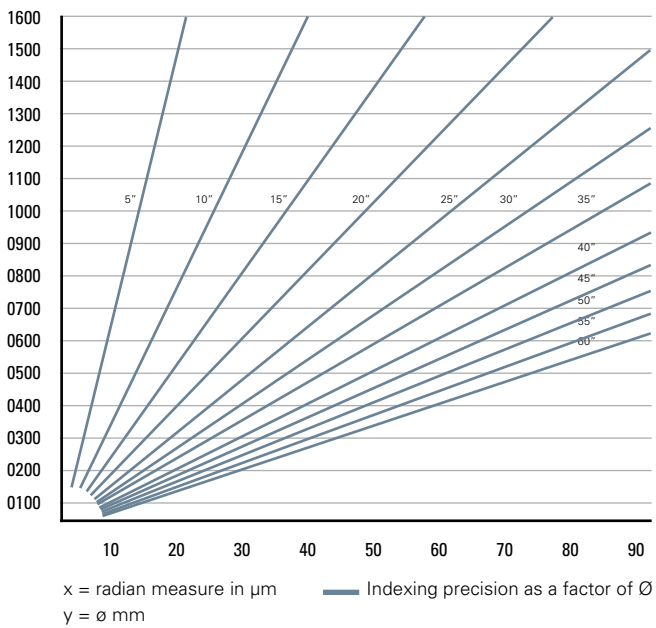

$$\text{Nominal indexing precision} = \pm \frac{\pi \times D \times T_g}{360 \times 3600}$$

D = Pitch circle diameter
 T_g = Brochure precision

Accuracy of circular run-out for additional plates

Diameter (mm)	Thickness (mm)	Flatness Quality A (mm)	Flatness Quality B (mm)
≤ 600	≥ 20	0.04	0.10
	< 20	0.06	0.15
≤ 800	≥ 20	0.06	0.15
	< 20	0.07	0.18
≤ 1100	≥ 20	0.07	0.18
	< 20	0.08	0.20
≤ 1400	≥ 25	0.08	0.20
	< 25	0.10	0.25
≤ 1800	≥ 25	0.10	0.25
	< 25	0.20	0.50
≤ 2500	≥ 30	0.15	0.40
	< 30	0.25	0.55

If we machine your additional indexing plate, $\pm 3''$ needs to be added to the indexing precision of the rotary indexing table specified in the diagram.

CALCULATION OF THE MOMENT OF MASS INERTIA

Solid body:

$J = 0.5 \times r_a^2 \times m_a$
 or
 $J = 0.125 \times m_a \times D_a^2$

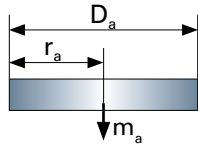

r_a = radius in m
 m_a = mass (weight) in kg
 D_a = diameter in m

Individual weights (approximation formula):

$J = 1.1 \times r_e^2 \times m_e \times n$

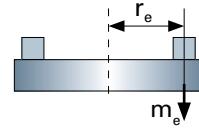

r_e = radius in m
 m_e = mass (weight) in kg
 n = number of individual masses

YOU CAN FIND DETAILED INFORMATION IN THE CHAPTER ENTITLED "INDEXING MACHINE BASES"

BASIC IDEA



INDEXING MACHINE BASES



STATIONARY AND ROTARY PLATES



EXAMPLES



CUSTOM EQUIPMENT



Tried-and-tested standard modules form the basis for perfectly matched system solutions. From the design, through the requisite precision and dimensions, all the way up to the colour: customers can select all parameters individually. You receive an acceptance certificate and the confidence of knowing that everything works together perfectly. Take advantage of our complete package for rotary table-based basic machines.

We support you in optimising time, costs and resources when creating your system. You have a single contact and receive everything from a single source, so you do not need to worry about interface problems.