

LS

LS 280 LINEAR ASSEMBLY SYSTEM



Linear Assembly System LS280 consisting of four assembly cells with locking station and base frame, as well as of belt sections, corner units and workpiece carriers.



LINEAR ASSEMBLY SYSTEM LS: SOPHISTICATED, MODULAR CELL DESIGN

MOTION

The cam profile with modified sine curve provides a very smooth and harmonic motion sequence at the workpiece carrier. This is the precondition for minimum exchange times and a long service life.

— v Velocity characteristics

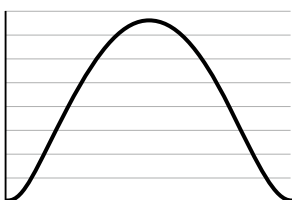

Pos. 1

Pos. 2

— a Acceleration characteristics

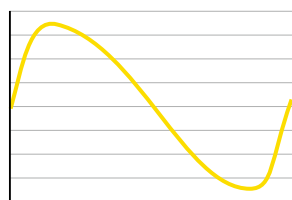

Pos. 1

Pos. 2

CLEAN ROOM CERTIFIED

LS280 CL – The solution for the cleanroom: The Linear Assembly System LS280 CL in a cleanroom suitable design is certified for the Air Cleanliness Class 6 in accordance with ISO 14644-1.



Fully automatic production system for lighting terminals. A 13-metre-long LS 280 linear assembly system with seven autonomous processing cells and a total of 45 processing positions forms the basis. Operating at a cycle time of 2.4 seconds, some 24,000 lighting terminals are manufactured per hour.



The advantages of the LS 280 result from a completely new, elegant drive principle. It combines a rotary indexing table with a transfer system, hence a cam drive with a belt system. This results in a radical reduction of the transport times as well as in an enormously high productivity. The modular designed cell concept also allows a flexible and extendable system design.

ADVANTAGES

- Proven cam drive
- Smooth, impact free motion sequence
- Short workpiece exchange times
- High positioning precision without additional stopping or indexing modules
- High level of availability
- Modular system design
- Independently functional assembly cells
- Adjustment of varying processing times
- High degree of reusability
- Stable basic structure made of steel
- Delivery with complete cell wiring
- High degree of reliability
- Maintenance free
- Complete functional and quality inspection
- Short implementation time
- Fast build-up assembly
- W.A.S. 2 – WEISS Application Software for easy and fast start-up
- Convincing price / quality ratio
- ESD-capability

HIGHER NUMBER OF CYCLES – MORE OUTPUT

The LS 280 achieves – due to the shortening of transport times – a cycle speed, which others can only dream of. The conventional workpiece carrier exchange – transporting, stopping, lifting and positioning – is replaced by one smooth and fast motion sequence – absolutely jerk and impact-free with up to 60 cycles per minute. With this exclusive drive principle the LS 280 combines the speed, precision and reliability of a rotary indexing table with the flexibility of a transfer system.

SIMPLE MOTION PRINCIPLE – HIGH LEVEL OF AVAILABILITY

What does not exist cannot break down. The simple and precise motion principle of the transport cam and the modular cell design considerably reduce the number of mechanical and electrical components. The availability of the LS 280 increases to the same degree. The single cells are uncoupled through “intelligent” belt sections. Short idle times between these assembly cells can be compensated by small buffers.

JERK AND IMPACT-FREE CARRIER TRANSPORTATION – NO VIBRATIONS AT THE CUSTOMER PRODUCT

The modified sinusoidal motion sequence within the transport cam together with the speed controlled belt sections in front of a cell provide transport through the system that is continuously smooth and impact-free. The frequency controlled belt drive unit reduces the transport energy of the workpiece carrier prior to the approach to the cam intake to one-hundredth in comparison with normal transport. This ensures that vibrations are avoided at the customer product.

MODULAR SYSTEM DESIGN – LOWER INVESTMENT COSTS

The LS 280 is based on a clear modular cell design. The elaborate design with a low number of components offers solutions of great simplicity and elegance – tailored for individual requirements. Additional components for stopping and indexing of the carriers are not required. The clearly defined cell modules keep labour costs low for build-up and start-up. Stability and reliability allow a three-shift operation with a minimum of service staff.

ADJUSTMENT OF VARYING PROCESSING TIMES – INCREASE OF PRODUCTIVITY

On a rotary indexing table, the longest processing time determines the cycle time of the system. The LS 280 however, allows the combination of different indexing pitches within one system through the simultaneous transfer of several workpiece carriers to execute time consuming operations parallel in line. Without elaborate lock out different processing times can be decoupled integrated to achieve a higher production output. The fast total frequency of the system remains in place.

MAINTENANCE-FREE OPERATION – HIGH RELIABILITY

The LS 280 allows a fully automatic and maintenance-free three shift operation due to hardened and ground motion tracks in connection with an integrated central lubrication system as well as ball bearing rollers at the workpiece carrier. The monitoring functions integrated in the control guarantee the maximum degree of operation reliability.

COMPARISON OF WORKPIECE EXCHANGE TIMES

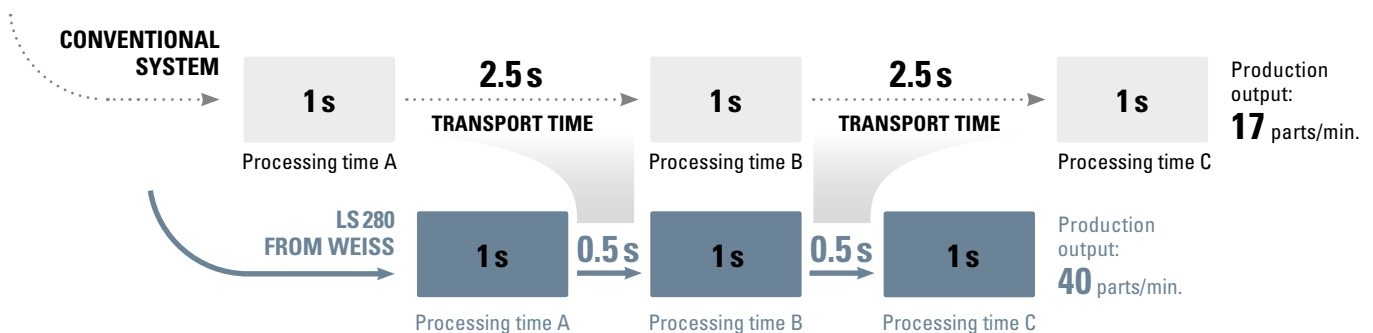

TIME AND LAYOUT EXAMPLE OF A LS 280 WITH DIFFERENT CUSTOMER PROCESSING TIMES AT THE INDIVIDUAL ASSEMBLY CELLS

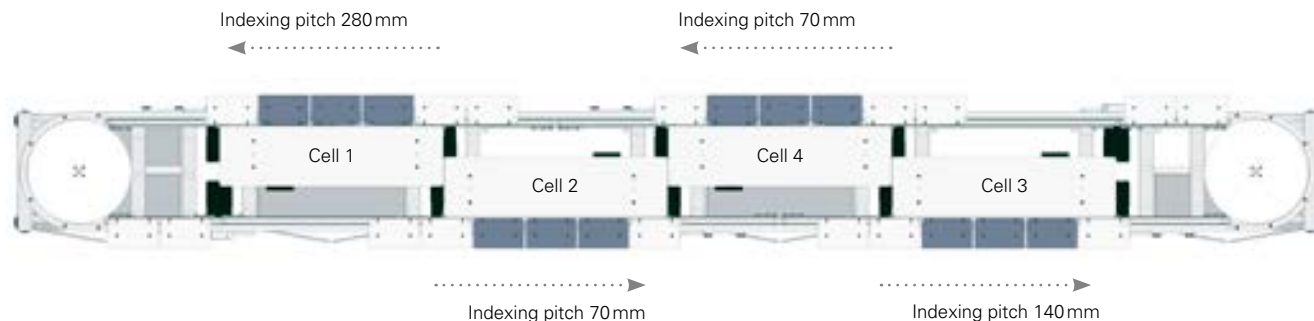

Indexing pitch of the cell (mm)	Workpiece exchange time (sec.)	Processing time customer (sec.)	Cycle time of a cell (sec.)	Resulting cycle time per part (sec.)
70	0.4	0.8	1.2 (1)	1.2
140	0.5	1.9	2.4 (2)	1.2
280	0.6	4.2	4.8 (3)	1.2

(1) sequential processing per part
 (2) parallel processing at 2 parts
 (3) parallel processing at 4 parts

ESD-CAPABILITY – ANTISTATIC TRANSPORT

There is no electrostatic charging due to the continuous steel design of the system which ensures that every workpiece carrier is earthed.

INDEPENDENTLY FUNCTIONAL ASSEMBLY CELLS – FLEXIBLE AND EXTENDABLE SYSTEM DESIGN

The LS280 is designed mechanically as well as from the control side as a cell concept. The single assembly cells contain decentralised control packages, which communicate with the PLC by a system bus. This ensures that subsequent extensions to a system or a division of a total system into separate sub-systems are possible without any problems. The stable basic design of the cells also ensures that no adjustments are required after the re-assembly.

SHORT REALISATION TIMES – TIME TO MARKET

Complete base machines can be set up with just a few stockable standard components in a very short time. Each system is performance tested and quality controlled prior to delivery. The parameter set of the system is therefore already individually adjusted and optimised.

We manufacture the mechanical interfaces such as mounting plates, workpiece carrier plates etc. according to customer drawings. The autonomous working assembly cells even allow the split-up of the work content to several suppliers. The above issues result in a time saving of several weeks for the customer.

CELL WITH LOCKING STATION



The locking stations serve primarily for simultaneous transport and positioning of a number of workpiece carriers. Depending on the indexing pitch and station type, the user has a varying number of locked processing positions at his disposal.

Along with stable steel base frames and top support plates the locking stations form the basis of an assembly cell of the Linear Assembly System LS 280.

The main item of the stations is formed by a cylindrical cam with which the workpiece carriers are engaged, transported and mechanically locked in a single motion sequence. This reliable drive principle enables shortest workpiece exchange times combined with a high positioning accuracy.

Despite working at high speed, the sinusoidal motion curve within the cylindrical cam guarantees a smooth, impact-free transportation of the workpiece carriers and therefore avoid vibrations at the transported product.

Two versions of the locking stations are available, single and double locking station. Both modules have the same drive concept, but differ through the number of available locked positions and the module length of 1200 mm or 2400 mm.

A twin cell configuration provides two independent working locking stations mounted back to back on one base frame. A common bigger top support plate is used in this case.

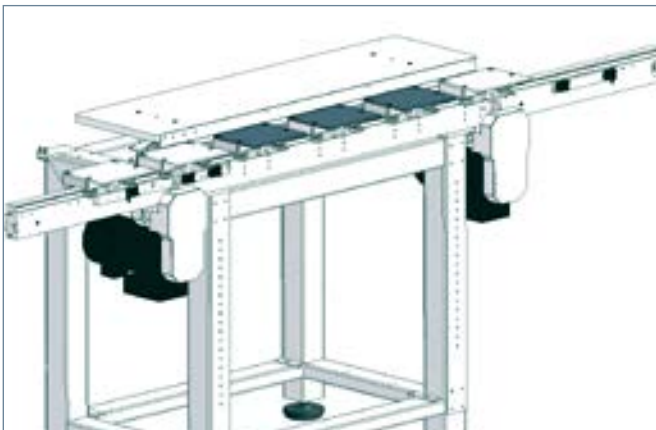

Single locking station

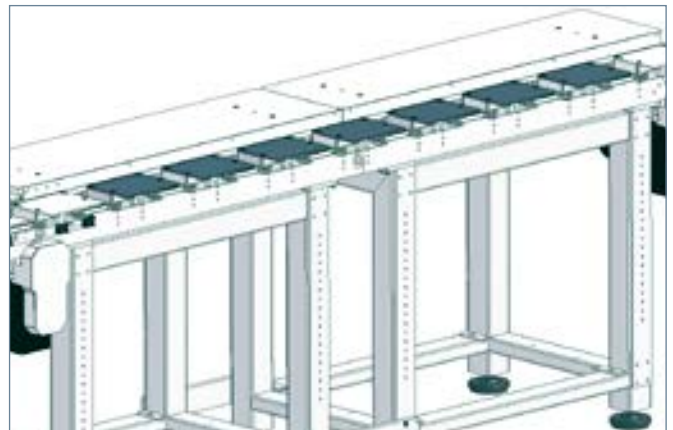

Double locking station

The locking stations are also designed to provide a mounting surface for handling modules, which are directly mounted on top of the assembly cell.

The top support plates are made of anodised aluminium or nickel-plated steel in the standard version. They can also be manufactured in accordance with customer specifications.

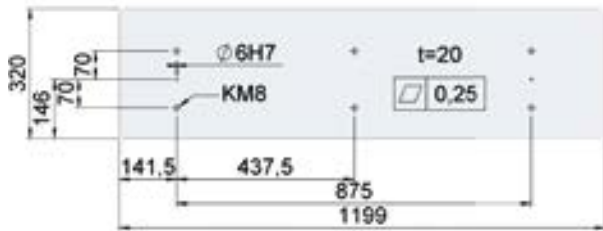

“One-sided” top support plate with standard hole pattern

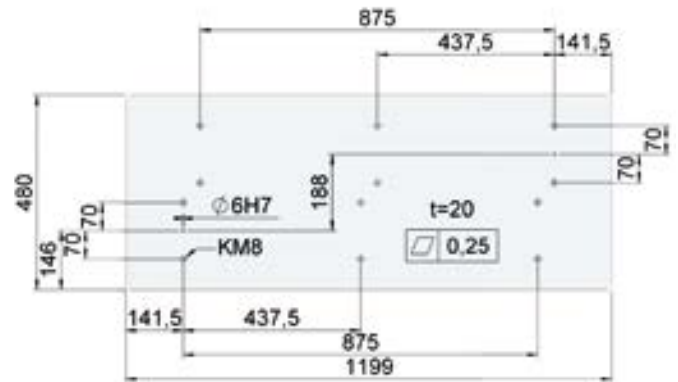

“Twin” top support plate with standard hole pattern

TECHNICAL DATA OF THE LOCKING STATIONS

Indexing pitch of the cell (mm)	Workpiece exchange time (sec.)	Number of available locked positions at each indexing pitch:	
		Single locking station	Double locking station
70	0.4*	10 positions	28 positions
140	0.5*	5 positions	14 positions
280	0.6*	3 positions	7 positions
560	1.2*	2 positions (1 x 2 pos. parallel)	6 positions (3 x 2 pos. parallel)

* Time from input of the start signal in the control of the cell to the output of the position signal from the control system.

Positioning precision:	X / Y axis +/- 0.03 mm Z axis: +/- 0.06 mm
Transport direction:	Counter-clockwise
Type of drive:	Three-phase motor



CELL WITH SINGLE LOCKING STATION – AVAILABLE LOCKED POSITIONS

Stationary and rotating plates according to customer drawings form part of our scope of delivery and are offered separately.

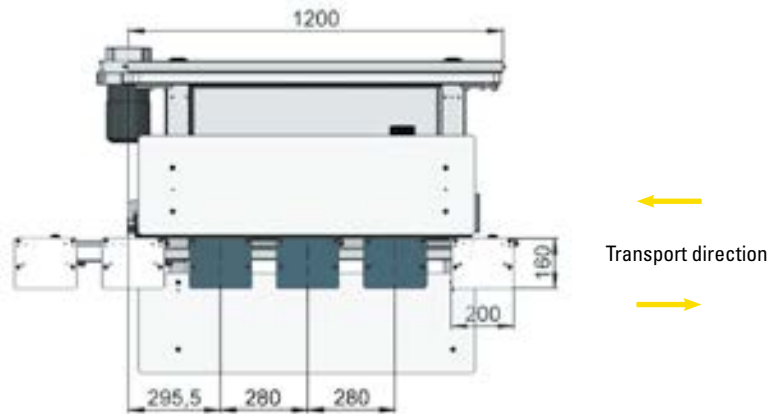

Indexing pitch: **280**
 Indexing pitch: **140**
 Indexing pitch: **560**

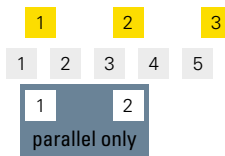

Number of available locked positions at each cycle

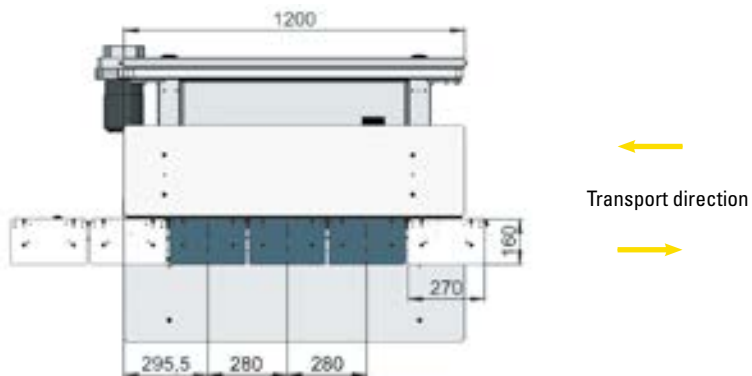

Indexing pitch: **70**



Number of available locked positions at each cycle

CELL WITH TWO SINGLE LOCKING STATIONS – TWIN ARRANGEMENT

Stationary and rotating plates according to customer drawings form part of our scope of delivery and are offered separately.

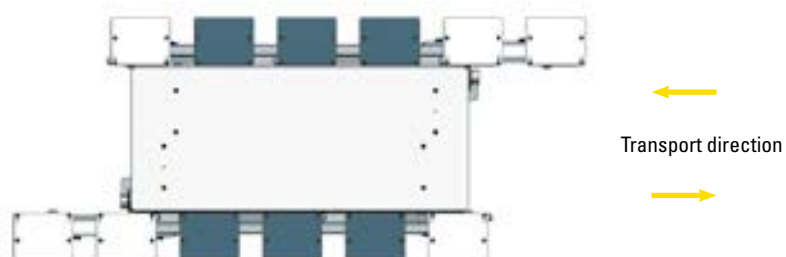

CELL WITH DOUBLE LOCKING STATION – AVAILABLE LOCKED POSITIONS

Stationary and rotating plates according to customer drawings form part of our scope of delivery and are offered separately.



Indexing pitch: **280**
 Indexing pitch: **140**
 Indexing pitch: **560**

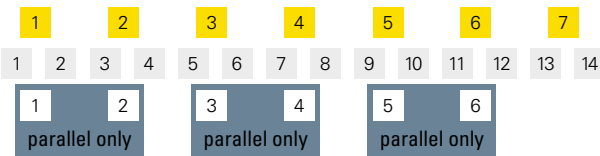

Number of available locked positions at each cycle

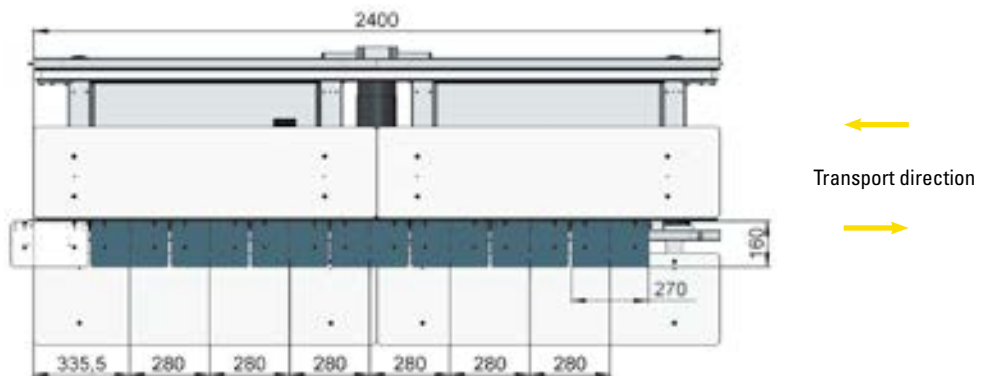

Indexing pitch: **70**



Number of available locked positions at each cycle

CELL WITH TWO DOUBLE LOCKING STATIONS – TWIN ARRANGEMENT

Stationary and rotating plates according to customer drawings form part of our scope of delivery and are offered separately.

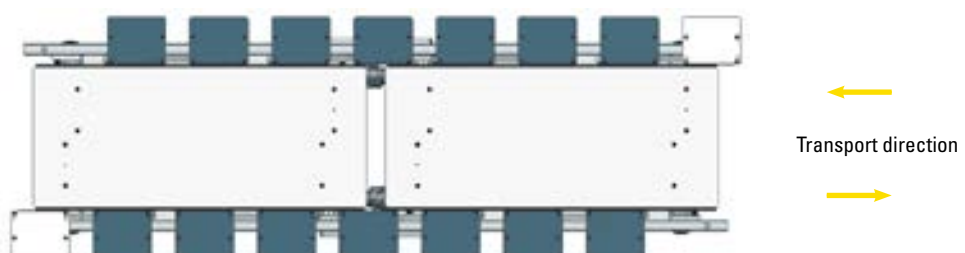

BELT SECTION



The belt sections are used for the transport of the workpiece carriers between locking stations. This ensures a decoupling of the individual cell modules and also serves as a small buffer between the processing stations. The workpiece carriers are friction driven on a transport belt. The belt sections are available in different lengths for individual layouts.

The outgoing belt section after a locking station runs with constant high speed while the ingoing belt section in front of a locking station is always speed controlled. This provides a rapid and impact-free transportation of the workpiece carriers between stations.

The high transport speeds also ensure a reduced number of required workpiece carriers on the free belt sections. The integrated control functions to regulate the transport speed as well as the weight independent pressing force of the carrier to the toothed transport belt, guarantee that wear is kept to a minimum.



Belt section with toothed transport belt



Driving unit with motor

TECHNICAL DATA OF THE BELT SECTION

Belt section lengths:	600, 1200, 1500, 1800, 2400 mm
Min. length between two cells:	1200 mm
Transport speeds:	19 m/min; 26 m/min; 41 m/min (at 50 Hz) (reduced speeds possible by additional feed rate reduction)
Toothed transport belt:	PU-belt, Nylon coated
Type of drive:	Three-phase motor

CORNER UNIT



180° and 90° corner units are available for the design of the system layout. They determine the geometric execution of the two possible layout types.

The workpiece carriers are friction driven on the anodised aluminium disk.



Example of 180° system layout



Example of 90° system layout

TECHNICAL DATA OF THE CORNER UNITS

Transport speeds:	15 m/min; 21 m/min; 34 m/min (at 50 Hz)
Type of drive:	Three-phase motor

WORKPIECE CARRIER



The workpiece carrier train consists of two workpiece carriers linked together by a connection rod. This forms the basis of the fixture of the workpiece. With longer workpieces the two carriers are linked together by a common carrier plate. The workpieces are guided on a continuous hardened and ground steel guide rail. On belt sections and corner units transport is provided by friction via a spring loaded plastic

shoe which is fitted to the underside of the workpiece carrier. This shoe exerts a constant pressure on the transport belts and corner units. Inside the locking station the workpiece carriers are moved and precisely positioned with the transport cam by the engagement of a cam roller.



Workpiece carrier train with two single carrier plates



Workpiece carrier train with one common carrier plate

DIMENSIONS

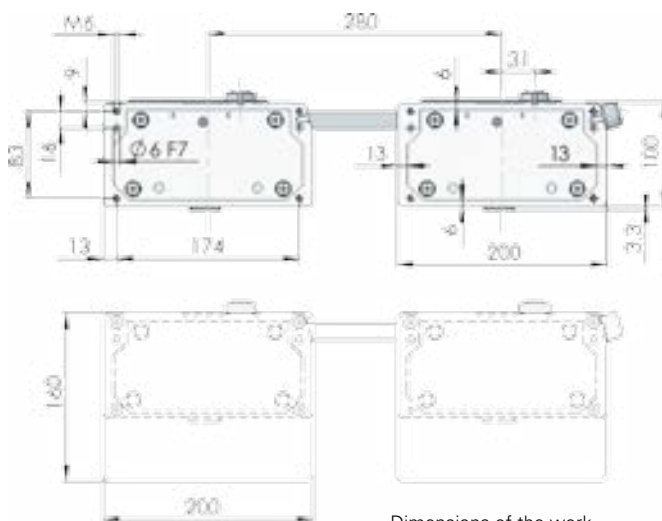

Dimensions of the workpiece carrier train

Note:

The design of the workpiece carrier pin holes enables the manual fitting of the carrier plate or the fixture. The mounting pins have a press fit in the carrier plate and a sliding fit in the workpiece carrier.

CARRIER PLATE

The carrier plates are designed to carry the product fixture of the customer. They project outwards over the carrier basic body and form the outermost contour of the system.

This design allows accessibility to the product from underneath as well as the possibility to support by vertical process forces. Components can also be suspended outside or through the carrier plates.



Carrier plate with standard hole pattern

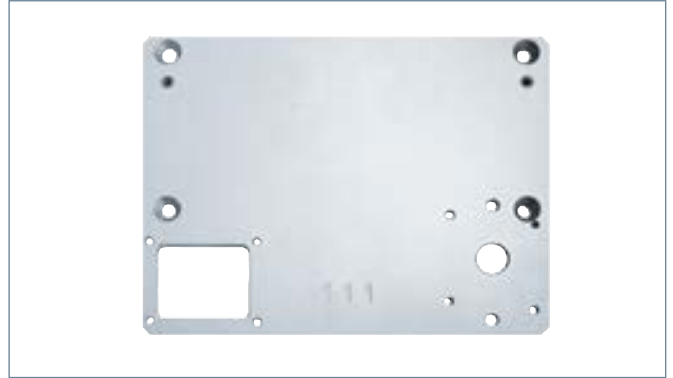

Carrier plate with customer-specific hole pattern

TECHNICAL DATA OF THE CARRIER PLATES

Material:	Steel, chemically nickel-plated
Standard dimensions (L x W x H):	200 x 160 x 5 mm (for pitch 140, 280, 560) 270 x 160 x 5 mm (for pitch 70, 140, 280, 560) 480 x 160 x 6 mm (for pitch 560 / common carrier plate) (other dimensions and designs on request)
Payload:	The maximum payload depends on the location of the customer fixture on the carrier plate and the cycle time of the system. The maximum payload is 4 kg.

SUPPORT IN THE CASE OF VERTICAL PROCESS FORCES

If vertical process forces occur in an application, for example when joining components, the carrier plates must be relieved by a stationary support from below. The carrier plates, which have an additional hardened rail underneath are driven to the

stationary cam rollers in the required positions. This type of support can take vertical process forces of up to approx. 3000 N. Depending on the point of force transmission, the supports in the outer area can be individually designed.



Stationary support



BASE FRAME WITH ACCESSORIES



The stable steel base frames form the basis for the locking stations of the linear Assembly System LS280. Handling modules can be installed directly on the locking stations and require no further supporting structure.

The working height of the assembly cell is 1020mm. The frame height can also be adapted in accordance with customer specifications. If the locking station is integrated into an existing customer machine frame, the frame feet can be dispensed with and the station is supplied on a flat base frame.



The base frame legs are machined flat on the front and rear sides complete with a standard fixing hole pattern. This allows for the fixing of optionally available aluminium side assembly plates. The fixing holes are precisely machined in steps of 50mm to provide height adjustment.

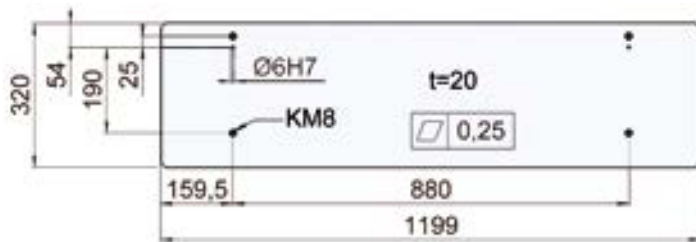

"Side" assembly plate with standard hole pattern

A high-quality switch cabinet is available for the cells, which is precisely integrated at the front or rear side of the base frames. The cabinet has the dimensions: 788 x 630 x 300 mm (W x H x D).

When using a side assembly plate it must be noted that the switch cabinet can only be opened if the plate is mounted in the uppermost position (dimension X = 200 mm between upper edge of the mounting plate and upper edge of the carrier plate).



Integrated switch cabinet on base frame

CENTRAL LUBRICATION SYSTEM



In order to ensure reliable, wear-free operation of the system, the guide rail tracks and transport cams are automatically lubricated

by the integrated central lubrication unit. The lubrication quantity and intervals are preset prior to delivery.



Central lubrication unit



Lubrication point in guide rail

MANUAL OPERATIONS

With processes that are difficult to automate, with fluctuating or uncertain production quantities, the user has the possibility to execute manual operations at a cell module.

With increasing production quantities, the manual operations

can be replaced by automated process stations, without mechanical modifications at the cell module.

Optionally, a height-adjustable footboard can be integrated into the base frame of this cell module.

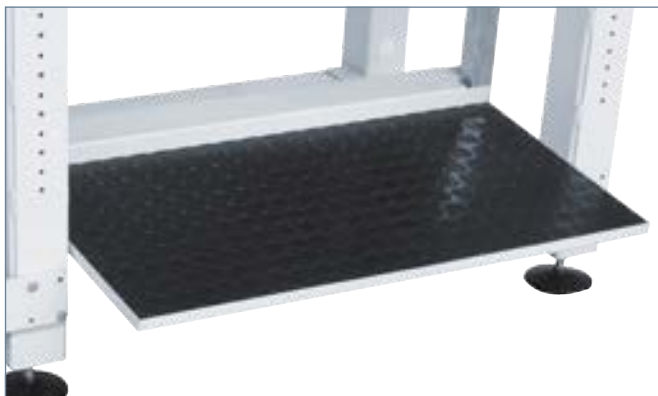

Footboard integrated in the base frame (optionally available)

CONTROL SYSTEM

- One master PLC per LS280 basic machine
- Decentralised control packages per assembly cell
- Cell communication via system bus
- Centrally saved parameter file
- Fieldbus interfaces for customer interface
- W.A.S. 2 LS software



CELL WIRING

The wiring concept follows the decentralised cell structure of the LS 280 and has a standardised "WEISS" design, based on DIN EN 60204. Basic commissioning of the LS 280 is therefore already performed in the factory, which secures a faster start-up on the customer's premises.

The solution includes:

- Creation of a project-specific circuit diagram
- Wiring of the LS components in the local cell control cabinet of the respective LS cell
- Installation of the wiring in line with WEISS specifications with individual core and cable labelling, including the connection points on the control cabinets
- Installation of electrical interfaces within the LS280 wiring at the mechanical interfaces of the transport units
- Commissioning and test run of the LS280 with control system



SAFETY AND SERVICE

- Frequency converter with integrated Safe Torque Off restart lock (SIL2, PL "d")
- Depending on the brand, configuration and wiring of the frequency converter, Safe Torque Off (SIL3, PL "e") can also be achieved
- Comprehensive monitoring functions
- Remote maintenance
- Global service

DIMENSIONS – LS 280 ASSEMBLY CELL WITH SINGLE LOCKING STATION

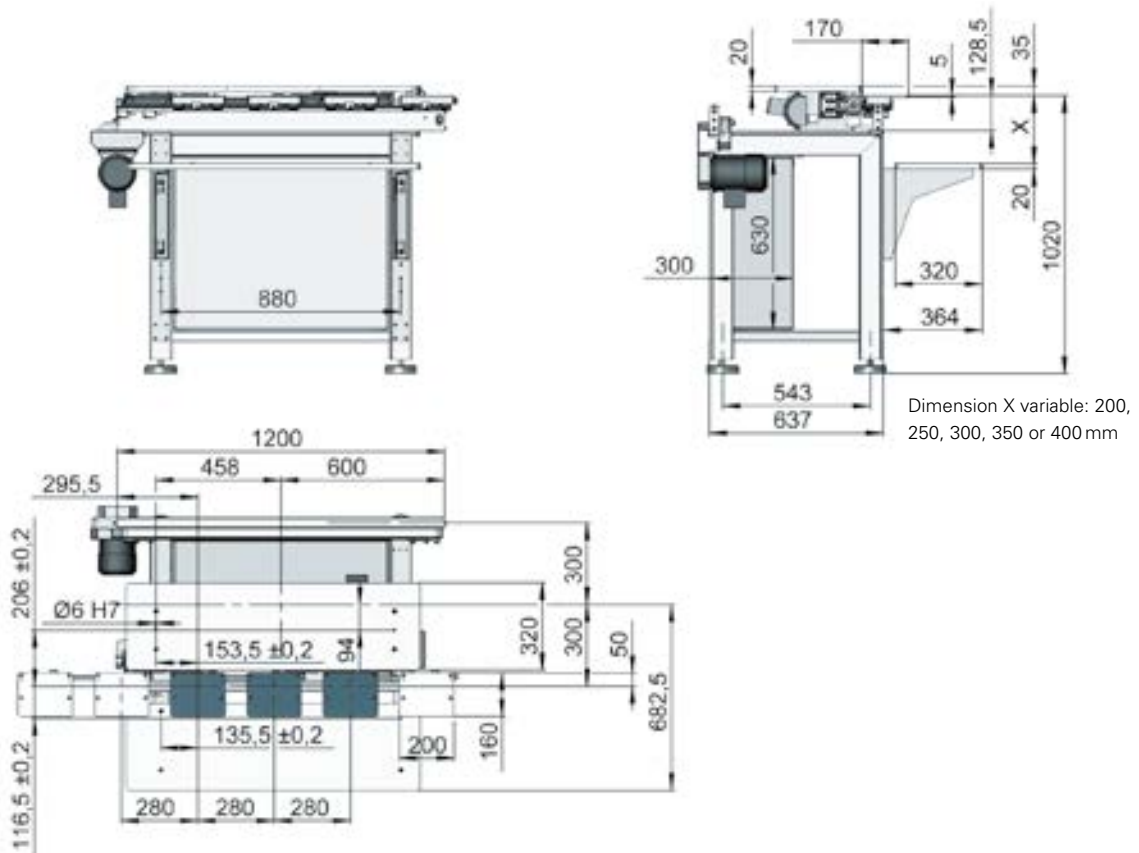

DIMENSIONS – LS 280 ASSEMBLY CELL WITH TWIN LOCKING STATION

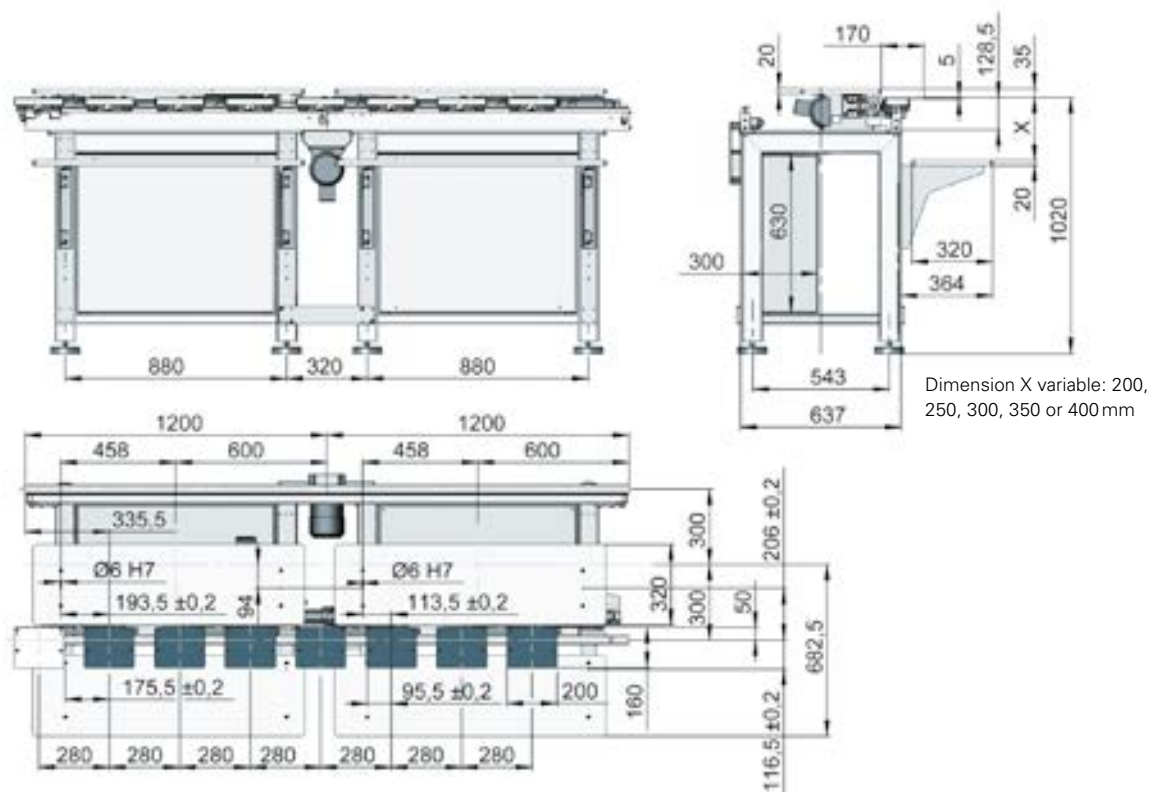

DIMENSIONS – LS 280 ASSEMBLY CELL WITH TWO SINGLE LOCKING STATIONS IN TWIN ARRANGEMENT

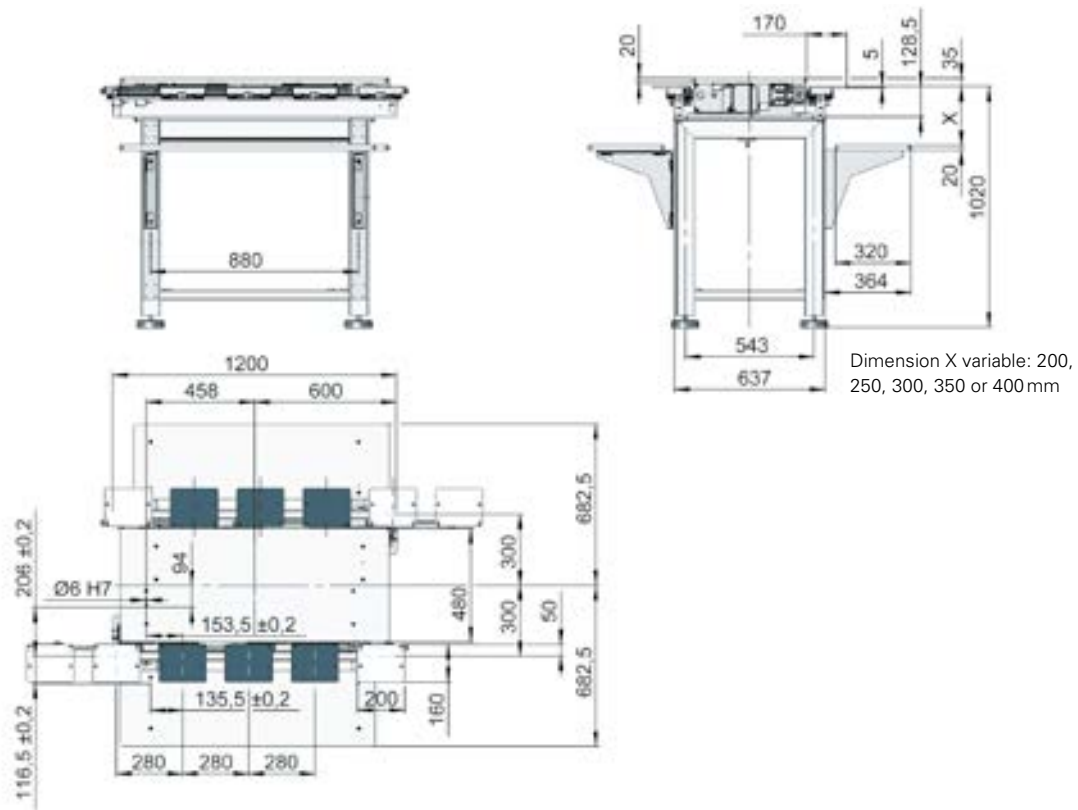

DIMENSIONS – LS 280 ASSEMBLY CELL WITH TWO DOUBLE LOCKING STATIONS IN TWIN ARRANGEMENT

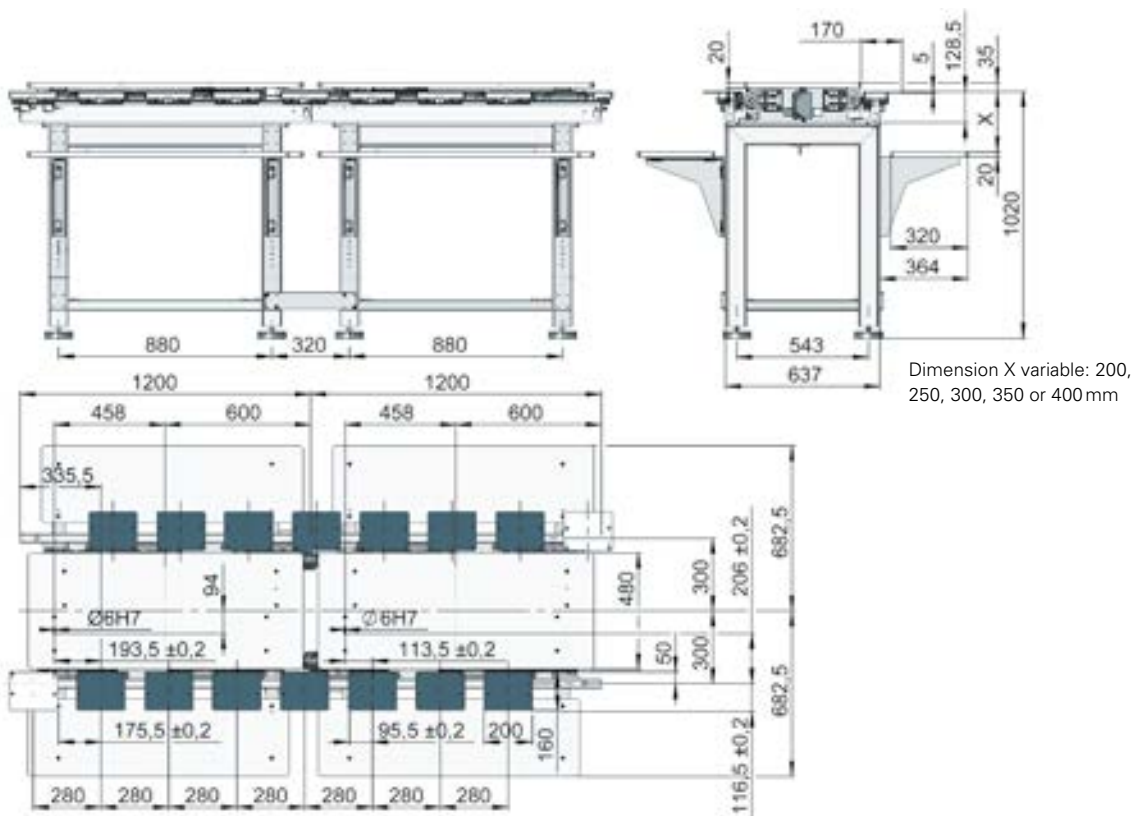

LAYOUT EXAMPLES FOR 180° SYSTEM

Number of locked workpiece positions: 21
 Indexing pitches used: 140 mm, 280 mm
 Space requirement of the basic machine
 (L x W): 4.8 m x 0.9 m

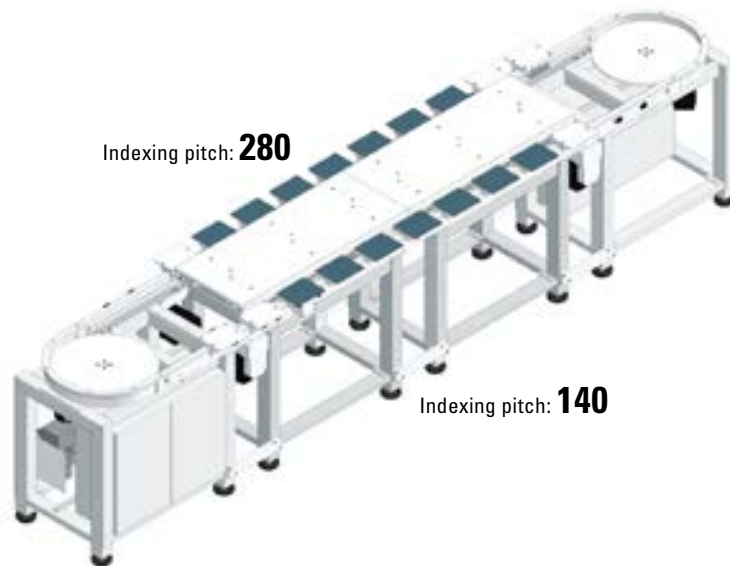

Number of locked workpiece positions: 34
 Indexing pitches used: 140 mm, 280 mm
 Space requirement of the basic machine
 (L x W): 7.2 m x 1.1 m

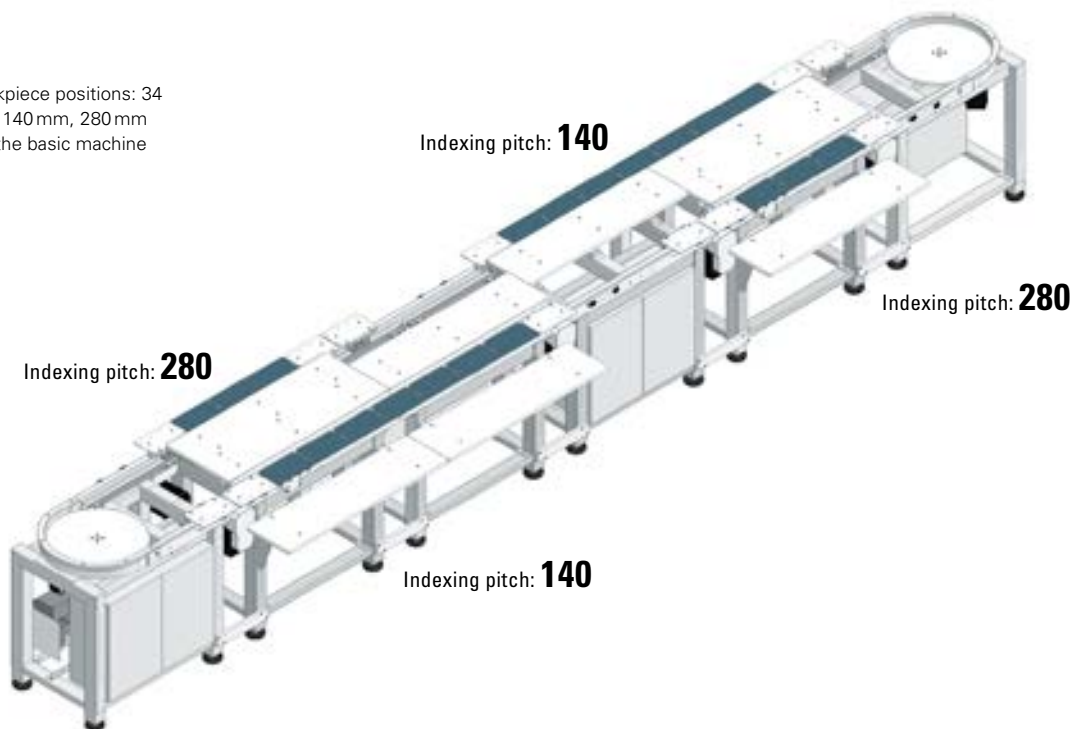

A selection of layout examples of the LS 280 linear assembly system is available as a CAD file at www.weiss-international.com.

LAYOUT EXAMPLES 180° SYSTEM

Number of locked workpiece positions: 16
Indexing pitches used: 140 mm, 280 mm
Space requirement of the basic machine
(L x W): 7.2 m x 1.4 m

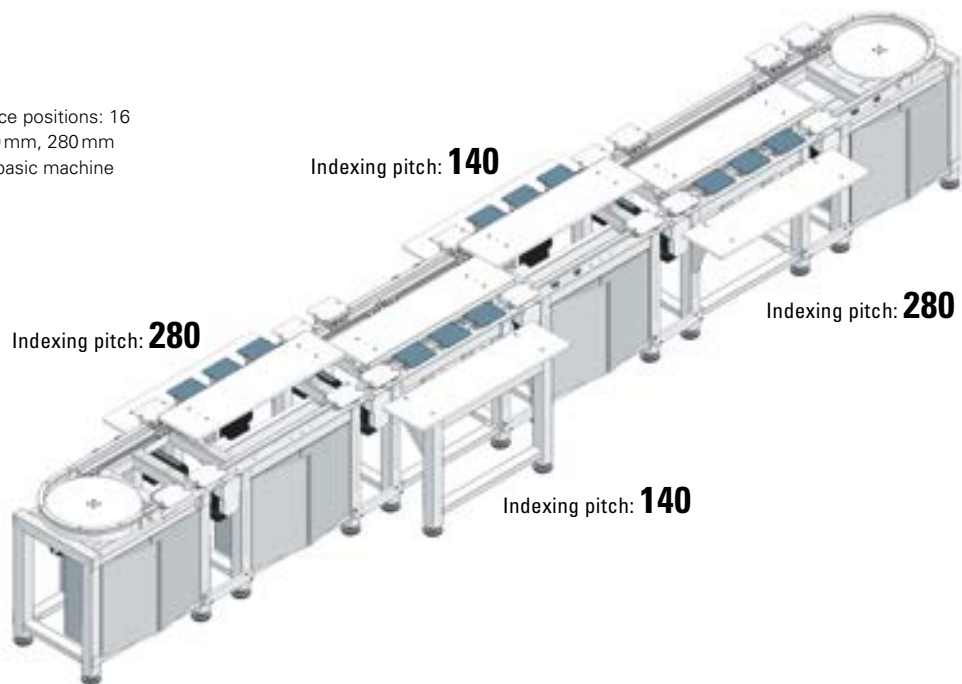

Number of locked workpiece positions: 64
Indexing pitches used: 70 mm, 140 mm, 280 mm
Space requirement of the basic machine
(L x W): 8.4 m x 1.4 m

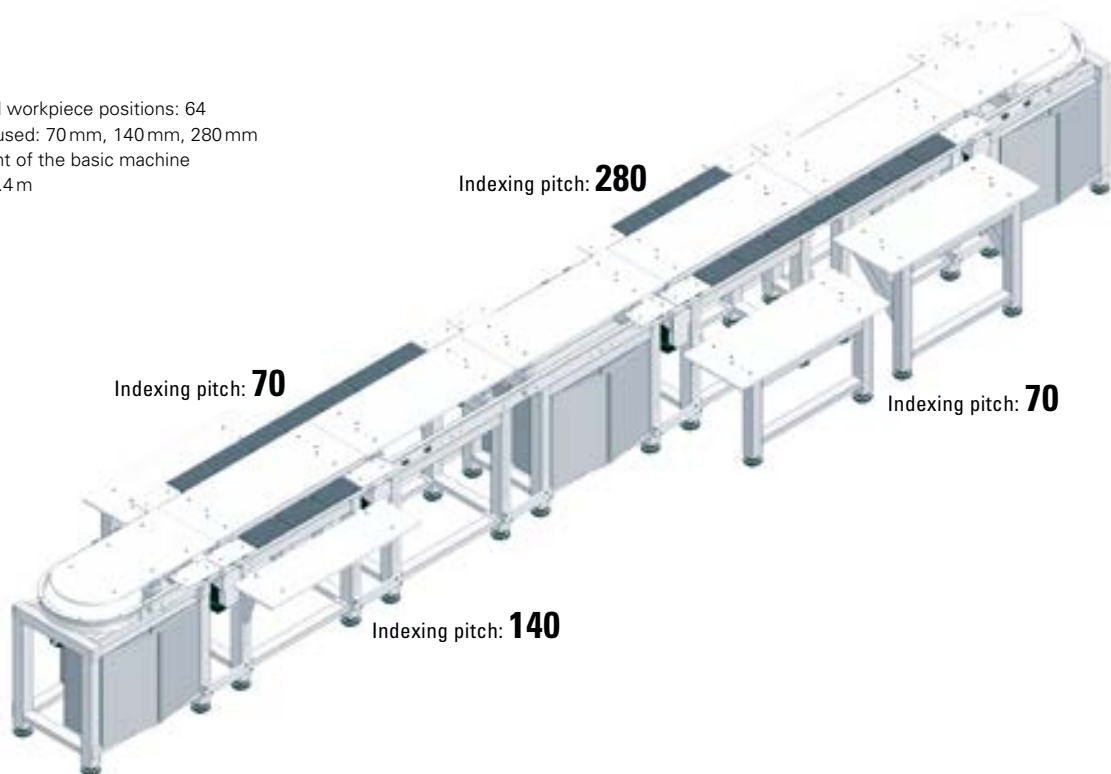

A selection of layout examples of the LS280 linear assembly system is available as a CAD file at www.weiss-international.com.

LAYOUT EXAMPLES 90° SYSTEM

Number of locked workpiece positions: 21
 Indexing pitches used: 140 mm, 280 mm
 Space requirement of the basic machine
 (L x W): 4.8 m x 2.3 m

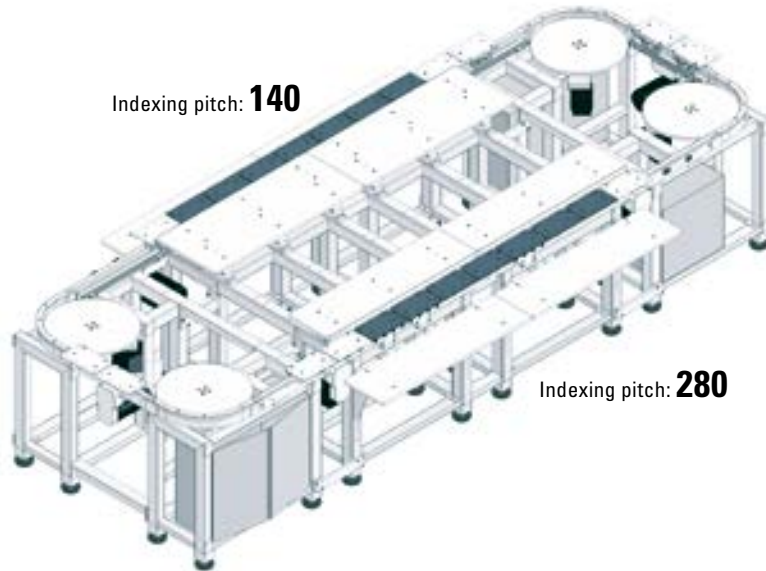

Number of locked workpiece positions: 26
 Indexing pitches used: 280 mm
 Space requirement of the basic machine
 (L x W): 9.6 m x 3.2 m

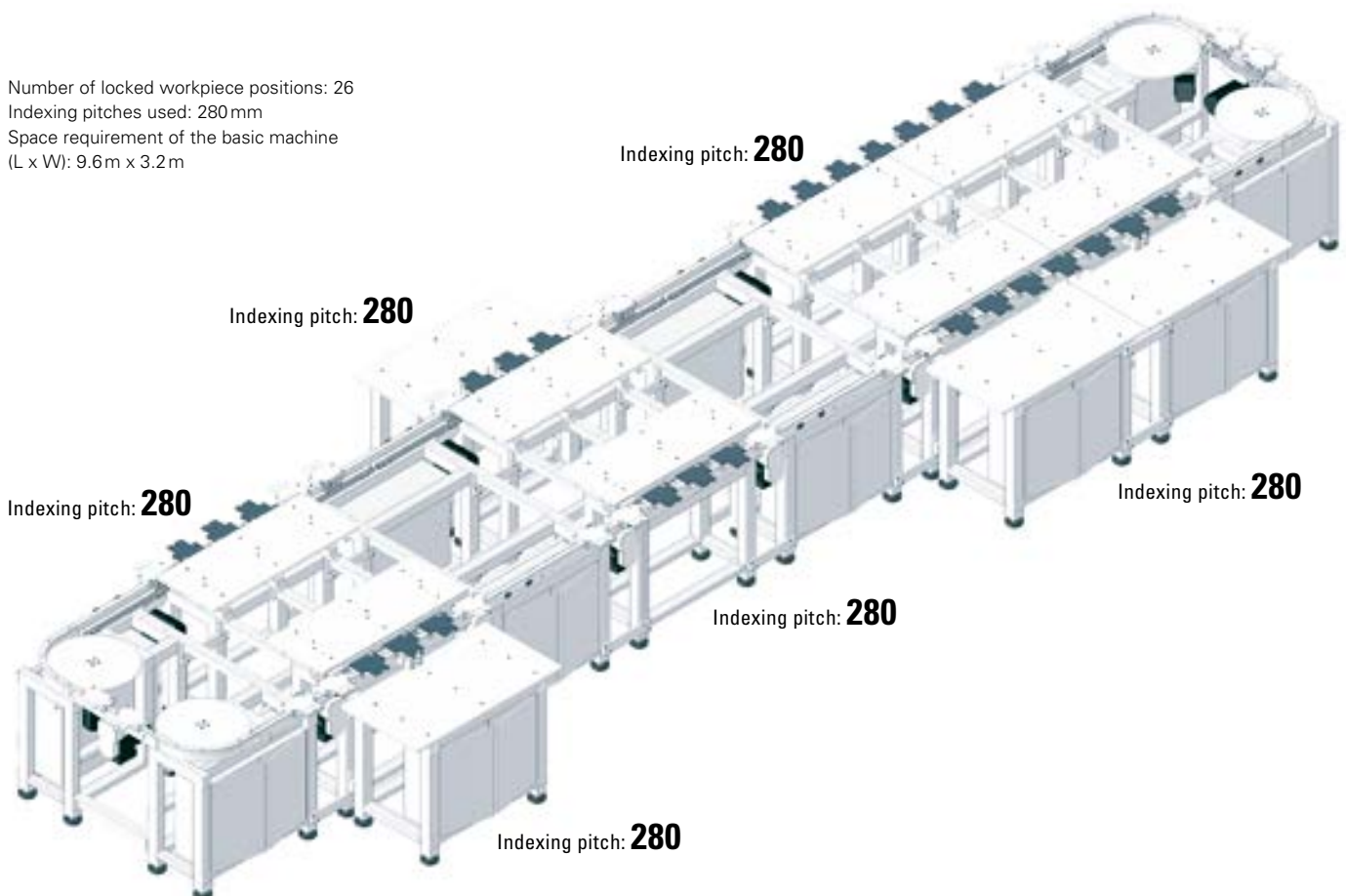

A selection of layout examples of the LS 280 linear assembly system is available as a CAD file at www.weiss-international.com.