

SR/SK

CUSTOMER-SPECIFIC SOLUTIONS | SR/SK INDEXING MACHINE BASES



CUSTOMER-SPECIFIC SOLUTIONS: A SYSTEM OF MATCHED COMPONENTS

ADVANTAGES

- **Guaranteed quality**
No nasty surprises. We produce and supply your machine from a single source as per your own specifications in terms of design, precision, dimensions and even colour – all guaranteed and documented. You receive a test report with every machine.
- **Fastest delivery time**
There's no need to reinvent the wheel: based on optimised standards, we implement your solution precisely with a keen focus on your goals and requirements. We then supply your machine within four to eight weeks.
- **Time and cost savings**
Reduced total costs through assumption of project management and engineering work, no interface problems and one allocated contact.
- **Surface treatment**
We are happy to offer all components in whatever surface finish you desire:
 - Anodised (available in 5 standard colours, others on request, Al)
 - Hard-coated (Al)
 - Bronzed (steel)
 - Nickel-plated (Al or steel)

BASIC IDEA>

INDEXING MACHINE BASES

STATIONARY AND ROTARY PLATES

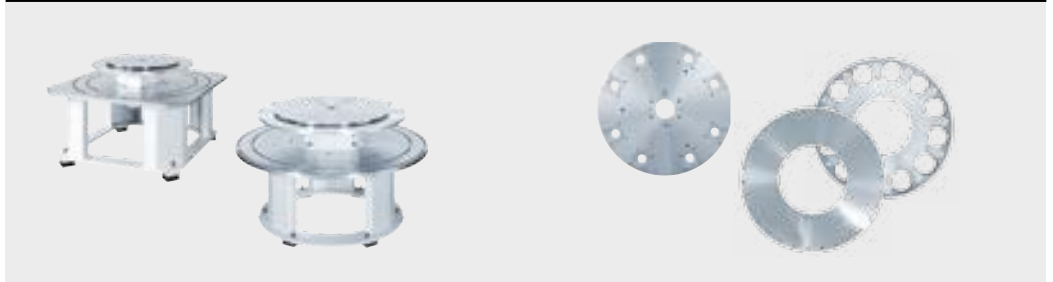

EXAMPLES>

CUSTOM EQUIPMENT

**INDIVIDUAL, CUSTOMISED
DESIGNS**



Tried-and-tested standard modules form the basis for perfectly matched system solutions. From the design, through the requisite precision and dimensions, all the way up to the colour: customers can select all parameters individually. You receive an acceptance certificate and the confidence of knowing that everything works together perfectly. Take advantage of our complete package for rotary table-based basic machines.

We support you in optimising time, costs and resources when creating your system. You have a single contact and receive everything from a single source, so you do not need to worry about interface problems.



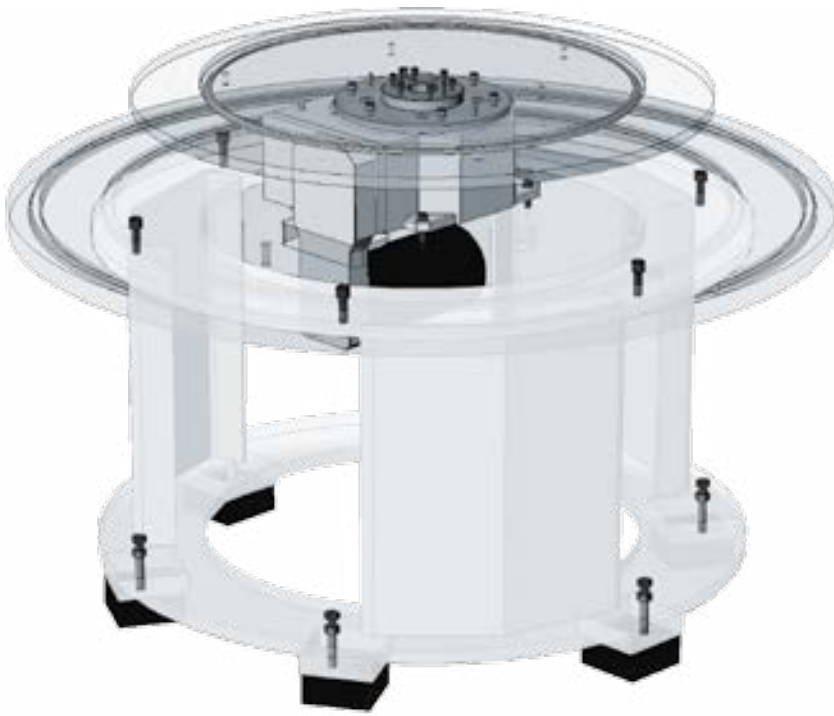

SR SERIES

SPECIAL FEATURES:

- Standard sizes:
SR 100B, SR 200B, SR 300B, SR 400B, SR 500B
- 2 - 4 standard ribbed legs depending on diameter (custom arrangement available on request)
- Customised diameters
- Customised sizes available upon request

ROTARY INDEXING TABLES

- Select the rotary indexing table suitable for your application
- Series TC/NC, TR/NR, TW, TO, CR all are available in various model sizes
- The overall height of your machine will be determined by the height of the indexing unit used and the length of the support legs.
- Laser measurement of the indexing precision possible on request

ROTARY PLATE

- Ultimate precision and machining on the latest CNC drilling machines in climate-controlled rooms
- Dimensions, manufacturing and surface treatments according to your specification
- Supplied with a quality certificate

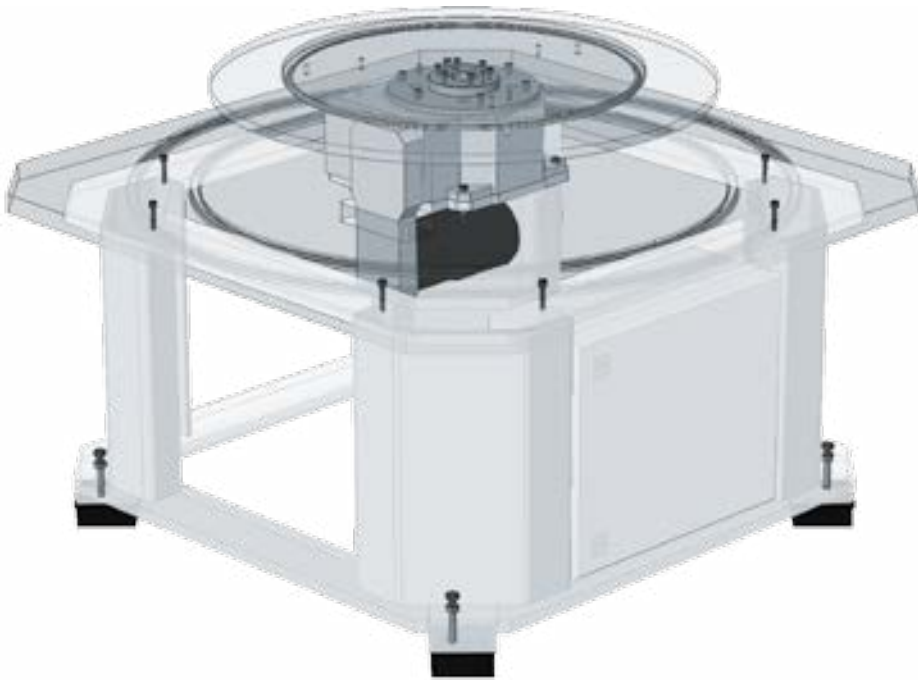

SK SERIES

SPECIAL FEATURES:

- Standard sizes: SK 100B, SK 200B, SK 300B
- Integrated switch cabinets available
- Any edge dimensions possible
- Customised sizes available upon request

BASE PLATES

- Round, square or rectangular
- Dimensions, material and processing according to your specification
- Machining according to your drawing
- T-slots possible
- Cable ducts standard

STATIONARY PLATE

- With integrated lip seal between stationary and rotating indexing plate
- In aluminium or steel, manufactured according to your drawing
- T-grooves possible for variable module arrangement

BASE FRAMES

- Round and square standard sizes
- Height adjustment possible
- Customised design upon request
- High quality rigid fabricated construction
- Control cabinets for the square model
- Height-adjustable and shock-absorbing feet

SR SERIES

TABLE OF DIMENSIONS FOR STANDARD VERSION (Attention! New type designation)

Type	Recommended rotary table type	ØA (Standard)	B	B*	H	ØI	ØJ	ØK
SR 100B	TC/NC 150 – 320, TW 150 – 300 TO 150 – 220, CR 300	1300	35	40	575	960	615	960
SR 200B	TC/NC 220 – 320T, TC 500, CR 400 TR/NR 750, PM 1100, TO 750, TW 200 – 300	1500	35	40	485	1200	815	1200
SR 300B	TC/NC 320, TC 500, TC 700, TW 300 TR/NR 750, TR/NR 1100, PM 1500, CR 400 – 700	1800	35	40	615	1350	967	1350
SR 400B	TC 500 – 700, TR/NR 1100, TR/NR 1500 CR 700 – 1000C	2200	35	40	690	1800	1357	1800
SR 500B	TR/NR 1500, TR/NR 2200, CR 1000–1300	2500	35	40	656	2200	1700	2200

General tolerances in conformity with DIN ISO 2768-m. Special tolerances upon request/dimensions variable.

* with T-slots

Notes: For the permissible loads of the stationary or rotary indexing plates, please refer to the "Rotary indexing table" chapter. Special machining according your drawing.

Rotary indexing ring table with base frame and raised supports

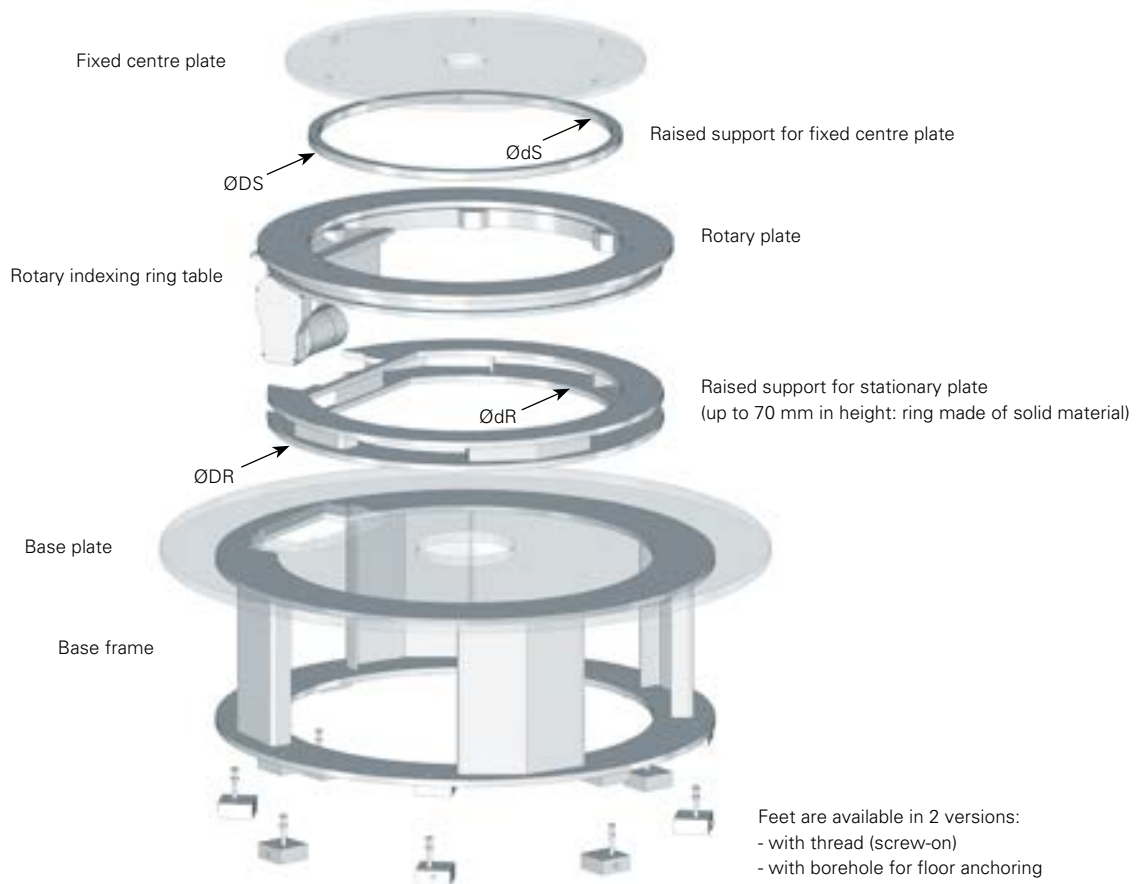
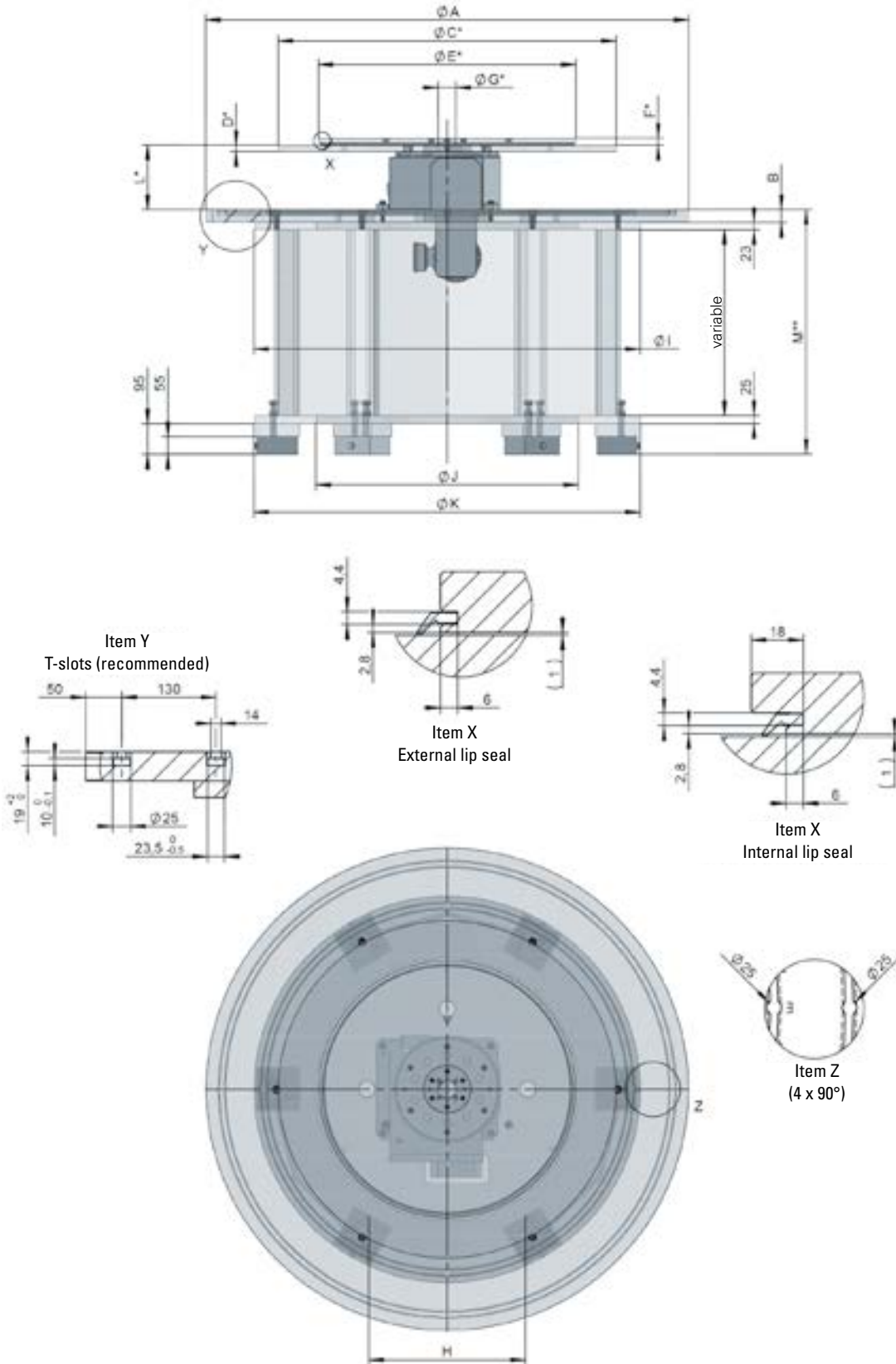

TABLE OF DIMENSIONS FOR RAISED SUPPORTS Raised supports are optionally available for TR/NR rotary indexing rings tables.

Table type	Raised support for fixed centre plate			Raised support for rotary indexing ring tables		
	ØDS	ØdS	Height	ØDR	ØdR	Height
TR/NR 750	485	410	21.5	770	440	variable
TR/NR 1100	795	720	32	1100	740	variable
TR/NR 1500	1130	1055	32	1420	1080	variable
TR/NR 2200	1745	1655	37	2200	1660	variable

DIMENSIONS

Please download the selected machine base from the internet (in 2D or 3D) directly into your CAD drawing. This will ensure you are using the latest model.



* For recommended dimensions and diameters, see "Rotary tables"

** Distance M varies according to the ridge height and can be changed by ± 3 mm by adjusting the feet

SK SERIES

TABLE OF DIMENSIONS FOR STANDARD VERSION (Attention! New type designation)

Type	Recommended rotary table type	□A (Standard)	B	B*	H	□I	□J	□K
SK 100B	TC/NC 150 – 320, TW 150 – 300 TO 150 – 220, CR 300	1300	35	40	410	1000	615	1000
SK 200B	TC/NC 220–320, TW 200–300 TR/NR 750, CR 400, TO 750	1480	35	40	610	1300	1007	1300
SK 300B	TC/NC 320, TC 500 – 700, TW 300, TR/NR 750, TR/NR 1100, CR 400 – 700, PM 1100, PM 1500	1800	35	40	710	1610	1310	1610

General tolerances in conformity with DIN ISO 2768-m. Special tolerances upon request/dimensions variable.

* with T-slots

Notes: For the permissible loads of the stationary or rotary indexing plates, please refer to the „Rotary indexing table“ chapter. Special machining according your drawing.



Example detailing SK300B, TC320T,
dial and stationary plates.

DIMENSIONS

Please download the selected machine base from the internet (in 2D or 3D) directly into your CAD drawing. This will ensure you are using the latest model.

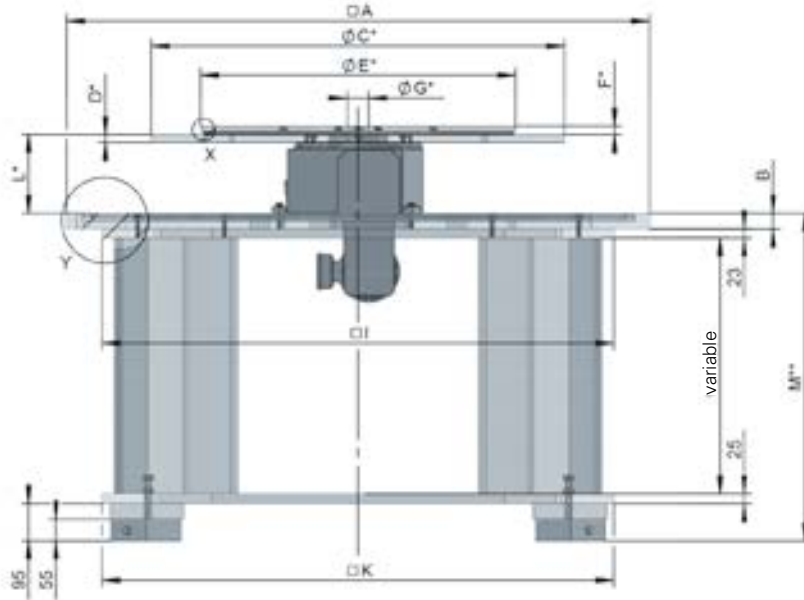

Item Y
T-slots (recommended)

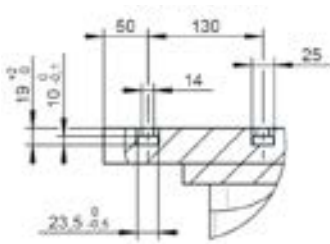

Item X
External lip seal

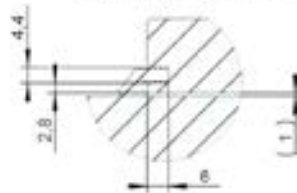

Item X
Internal lip seal

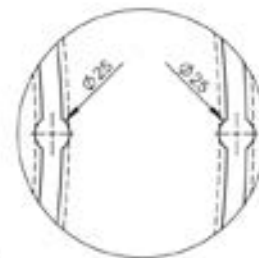
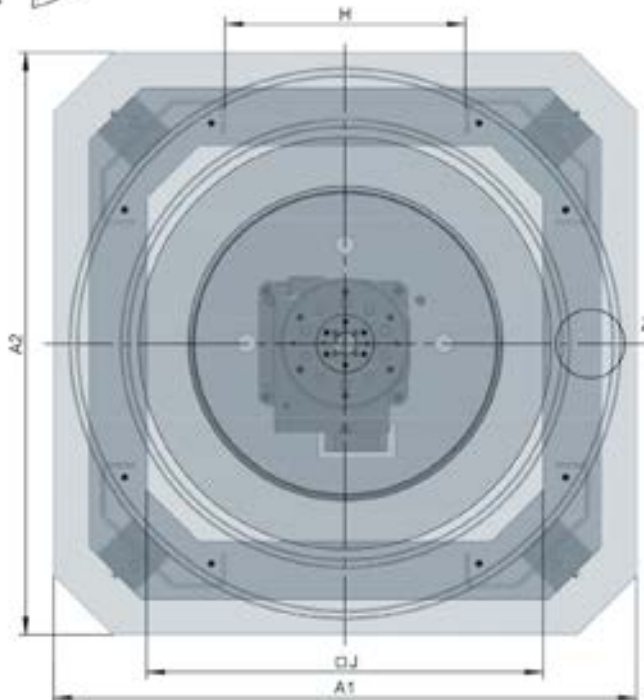
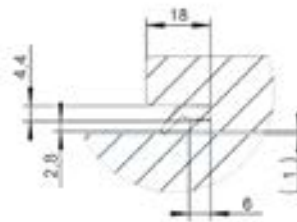

Item Z
(4 x 90°)

* For recommended dimensions and diameters, see "Rotary indexing tables"

** Distance M varies according to the ridge height and can be changed by ±3 mm by adjusting the feet

PLATES

CUSTOMER-SPECIFIC SOLUTIONS | PLATES

STATIONARY PLATE

- Standard model with integrated sealing lip between stationary and rotating plate in steel or aluminium
- Delivered with assembly hole and bore pattern (incl. middle bore) appropriate for the table, T-slots possible
- Manufactured in Flatness Quality B including 3 off blanked machining holes
- Please note! All drill holes are blind in order to avoid the accidental blocking of the rotary indexing table

ROTARY PLATE

- Precision machined from aged material in a controlled temperature environment
- Recommended to be manufactured from aluminium to minimise weight
- With appropriate assembly holes and bore patterns (plate is located on the rotary indexing table with two dowel pins)

BASE PLATE

- 3 cable ducts as standard
- Including cut out for drive when mounted on underside, if required
- Prior to positioning your automation equipment please observe the standard hole pattern for fixing the base plate to the base frame
- T-slots possible

GUARANTEED PRECISION

- We guarantee the highest precision for flatness and repeatability. Measurements are taken from the indexing dial plate when assembled to the rotary indexing unit. The precision is documented in an inspection certificate.
- Indexing accuracy of hole patterns – up to Ø 1800 mm ± 3" over Ø 1800 mm ± 8"
- Laser measurement of the indexing precision possible
- Indicate machining concerning the bore pattern
- Please forward your drawing by E-Mail in pdf or DXF format

MANUFACTURING NOTE

Dial plates with a diameter more than 550 mm will have 3 auxiliary threads. At stationary plates these threads are closed by plugs. We will inform you about the possible pitch diameter and the thread size if necessary.

DELIVERY TIME

- Depending on the diameter, between four and eight weeks – including drilling work
- Standard dimensions can be supplied at short notice. (outer diameters: 600, 700, 800, 1000, 1100, 1200 and 1600)
- Surface treatment: 1 week additional processing time required
- Aluminium: anodised
- Steel: chemically nickel-plated



AXIAL ACCURACY FOR ROTARY TABLES WITH PLATES

Diameter (mm)	Thickness (mm)	Flatness Quality A (mm)	Flatness Quality B (mm)
< 600	≥ 20	0.04	0.10
	< 20	0.06	0.15
< 800	≥ 20	0.06	0.15
	< 20	0.07	0.18
< 1100	≥ 20	0.07	0.18
	< 20	0.08	0.20
< 1400	≥ 25	0.08	0.20
	< 25	0.10	0.25
< 1800	≥ 25	0.10	0.25
	< 25	0.20	0.50
< 2500	≥ 30	0.15	0.40
	< 30	0.25	0.55