



FIPA Vacuum cups for the food industry



- > The requirements for vacuum cups in the food industry range from the handling of pre-packaged food up to the direct handling of unpackaged foodstuffs
- > The special shape and consistency of the products usually requires marked adjustments to the design of the cup
- > All FIPA vacuum cups for the food industry are manufactured from FDA-approved materials



Vacuum cups for chocolates - SL-P

- > Extremely flexible and adaptable suction lip for leak-free sealing of three-dimensional product surfaces
- > Low-marking and FDA-approved

Flat vacuum cups - SL-PF

- > Diameter: 16 - 22 mm

> See page 58

Bellows vacuum cups - SL-PB

- > Diameter: 12 - 16 mm

> See page 125



Vacuum cups for baked goods - SL-B

- > Multiple folds ensure a high degree of height adjustment and gentle product handling
- > FDA-approved
- > Diameter: 34 - 60 mm

> See page 126



Detectable vacuum cups for baked goods - SL-BD

- > Detectable, providing optimum assurance that the product is not contaminated by vacuum components
- > Multiple folds ensure a high degree of height adjustment and gentle product handling
- > FDA-approved
- > Diameter: 35 - 40 mm

> See page 128



Vacuum cups for eggs - SL-E

- > Bellows vacuum cups in a design specially optimised for handling eggs
- > Gentle attachment to the product and a high lifting motion thanks to a long vacuum cup lift
- > FDA-approved
- > Diameter: 33 - 34 mm

> See page 129



Series | Flat vacuum cups SF

Flat vacuum cups for chocolates - SL-PF

Flat vacuum cups for chocolates - SL-PF



Product Description

Flat vacuum cups made of FDA-approved material for handling delicate products with heavily textured surfaces.

Advantage

- > Gentle handling of the most sensitive surfaces
- > Also suitable for three-dimensional products, e.g. chocolates

Technical data

Item no.	Model / Lip dimensions	↓	Material / Colour
107.016.008.*	SL-PF-16	2.4	SI (tr)
102.018.345.*	SL-PF-18	--	SI (tr)
107.018.004.*	SL-PF-18A	--	SI (tr)
102.022.043.*	SL-PF-22	5	SI (tr)

Accessories

Item no.	Suitable fittings				
	M5-male	G1/8-male	G1/8-female	G1/4-male	G1/4-female
107.016.008.*	--	270.132 (p.417)	270.114 (p.422)	270.043 (p.425)	270.178 (p.431)
102.018.345.*	270.443 (p.410)	270.238 (p.417)	270.110 (p.422)	270.534 (p.425)	--
107.018.004.*	270.399 (p.410)	270.033 (p.416)	270.478 (p.421)	--	--
102.022.043.*	--	270.112 (p.419)	270.114 (p.422)	270.113 (p.425)	270.178 (p.431)

* When ordering please add the appropriate material code to item no. You will find it in the foldout.
Average holding forces for vacuum cups you will find on page 760



Bellows vacuum cups for chocolates - SL-PB



Product Description

Bellows vacuum cups made of FDA-approved material for handling delicate products with heavily textured surfaces.

Advantage

- > Gentle handling of the most sensitive surfaces
- > Also suitable for three-dimensional products, e.g. chocolates

Technical data

Item no.	Model / Lip dimensions	↓	Material / Colour	Number of folds
21.012.079.*	SL-PB-12	7	SI (w)	2.5
27.016.001.*	SL-PB-16	6	SI (tr)	1.5

Accessories

Suitable fittings

Item no.	M5-male	M10-male	G1/8-male	G1/8-female	G1/4-male	G1/4-female
21.012.079.*	270.443 (p.410)	--	270.238 (p.417)	270.110 (p.422)	270.534 (p.425)	--
27.016.001.*	270.244 (p.410)	270.177 (p.416)	--	--	270.451 (p.426)	270.452 (p.431)

Dimensions

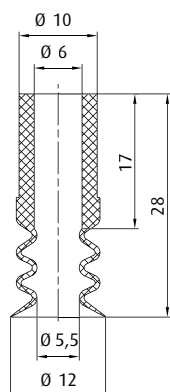

Drawing A

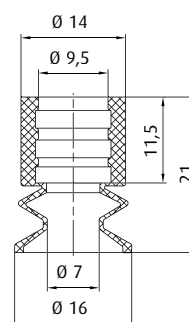

Drawing B

Item no.	Drawing
21.012.079.*	A
27.016.001.*	B

* When ordering please add the appropriate material code to item no. You will find it in the foldout. Average holding forces for vacuum cups you will find on page 760



Series | Bellows vacuum cups SB

Vacuum cups for baked goods - SL-B

Vacuum cups for baked goods - SL-B



Product Description

Bellows vacuum cups especially suitable for baked goods such as waffles, bread, rolls, pizzas and donut.

Advantage

- > Large degree of leveling
- > Gentle attachment to the product
- > Good holding strength through optimised lip geometry
- > FDA-compliant

Ordering notes:

Matching assembly aid for special fitting 270.419: Item No. 90.007

Technical data

Item no.	Model / Lip dimensions	Number of folds	Number of folds	Material / Colour
21.034.179._*	SL-B-34	12	2.5	SI (tr)
25.038.016._*	SL-B-38	24	4.5	SI (tr)
27.039.017._*	SL-B-38A	20	5.5	SI (tr)
25.040.043._*	SL-B-40	24	4.5	SI (tr)
25.040.058._*	SL-B-40A	25	4.5	SI (bl)
21.060.074._*	SL-B-60	12	2.5	SI (tr)

Accessories

Item no.	Suitable fittings				
	Without Thread	M6-male	G1/4-male	G1/4-female	G1/2-male
21.034.179._*	--	270.039 (p.414)	--	--	--
25.038.016._*	270.419 (p.441)	--	270.183 (p.431)	270.182 (p.434)	--
27.039.017._*	270.419 (p.441)	--	270.183 (p.431)	270.182 (p.434)	--
25.040.043._*	270.419 (p.441)	--	270.183 (p.431)	270.182 (p.434)	--
25.040.058._*	270.419 (p.441)	--	270.183 (p.431)	270.182 (p.434)	--
21.060.074._*	--	--	--	--	270.372 (p.437)

* When ordering please add the appropriate material code to item no. You will find it in the foldout.
Average holding forces for vacuum cups you will find on page 760



Dimensions

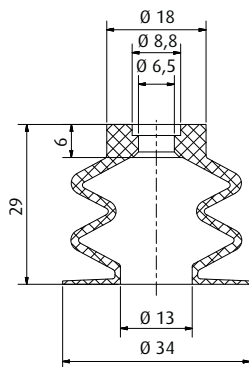

Drawing A

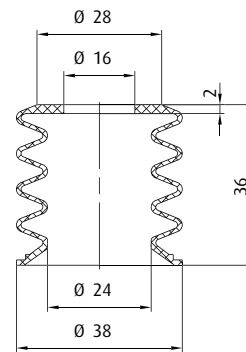

Drawing B

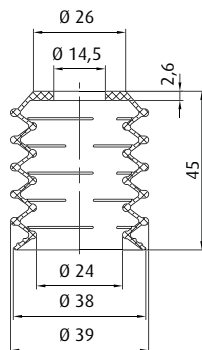

Drawing C

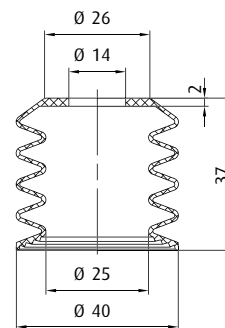

Drawing D

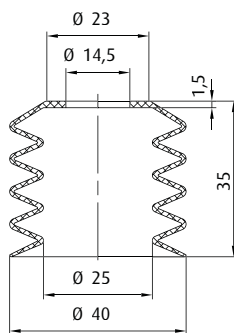

Drawing E

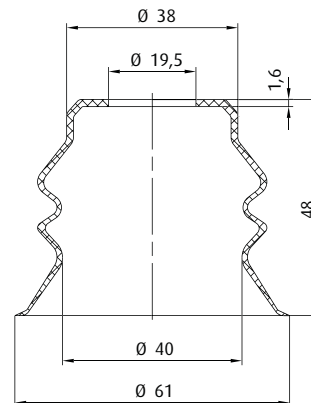

Drawing F

Item no.	Drawing
21.034.179._*	A
25.038.016._*	B
27.039.017._*	C
25.040.043._*	D
25.040.058._*	E
21.060.074._*	F

* When ordering please add the appropriate material code to item no. You will find it in the foldout.
Average holding forces for vacuum cups you will find on page 760



Series | Bellows vacuum cups SB

Detectable vacuum cups for baked goods - SL-BD

Detectable vacuum cups for baked goods - SL-BD



Product Description

Bellows vacuum cups especially suitable for baked goods such as bread, rolls or pizza. The vacuum cup material used is a special mixture that can be detected, for example by metal detectors from SAFELINE, and then separated and discarded.

Advantage

- > Detectable
- > FDA-compliant

Ordering notes:

Matching assembly aid for special fittings 270.419: Item No. 90.007

Technical data

Item no.	Model / Lip dimensions		Number of folds	Material / Colour
25.035.069._*	SL-BD-35	25	4.5	SI (r)
25.040.066._*	SL-BD-40	28	4.5	SI (br), SI (bl)

Accessories

Item no.	Without Thread
25.035.069._*	270.419 (p.441)
25.040.066._*	270.419 (p.441)

Dimensions

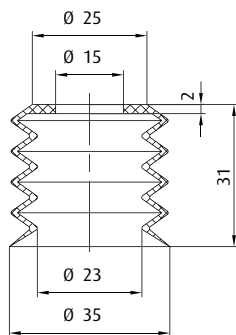

Drawing A

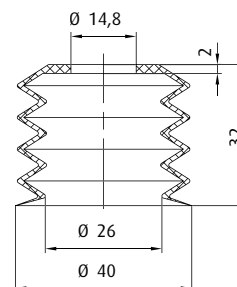

Drawing B

Item no.	Drawing
25.035.069._*	A
25.040.066._*	B

* When ordering please add the appropriate material code to item no. You will find it in the foldout.
Average holding forces for vacuum cups you will find on page 760



Vacuum cups for eggs - SL-E



Product Description

Bellows vacuum cups made of FDA-compliant silicone in a design specially optimised for handling eggs. Very long vacuum cup lift.

Advantage

- > Good absorption
- > Great stroke movement

Technical data

Item no.	Model / Lip dimensions	Number of folds	Material / Colour
27.033.008._*	SL-E-33	16	SI (tr)
27.034.023._*	SL-E-34	39	SI (r)

Accessories

Item no.	Suitable fittings				
	M5-male	G1/8-male	G1/8-female	G1/4-male	G1/4-female
27.033.008._*	--	270.132 (p.417)	270.114 (p.422)	270.208 (p.425)	270.178 (p.431)
27.034.023._*	270.443 (p.410)	270.238 (p.417)	270.110 (p.422)	270.534 (p.425)	--

Dimensions

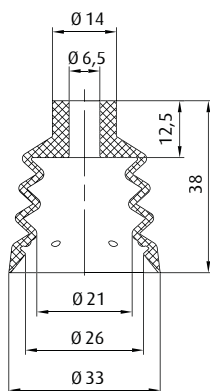

Drawing A

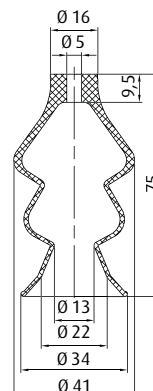

Drawing B

Item no.	Drawing
27.033.008._*	A
27.034.023._*	B

* When ordering please add the appropriate material code to item no. You will find it in the foldout. Average holding forces for vacuum cups you will find on page 760



Series | Bellows vacuum cups SB

Bellows vacuum cups, 1.5 and 2.5 folds - SV-SB

Bellows vacuum cups, 1.5 and 2.5 folds - SV-SB



Product Description

Bellows vacuum cups, 1.5 and 2.5 folds, for standard packaging machines. Soft, flexible sealing lip for smooth contact. FDA-compliant materials (SI).

Advantage

> Gentle handling of sensitive products

Technical data

Item no.	Model / Lip dimensions		Number of folds	Material / Colour
Bellows vacuum cups 1.5 folds - SV-SB1				
23.016.232._*	SV-SB1-16	6	1.5	SI (tr)
23.030.230._*	SV-SB1-30	7	1.5	NR (gr)
Bellows vacuum cups 2.5 folds - SV-SB2				
21.030.030._*	SV-SB2-30	13	2.5	SI (tr), NR (bl)
21.040.132._*	SV-SB2-40	11	2.5	SI (tr), SI (bl)

Accessories

Item no.	 Suitable fittings				
	M5-male	M6-male	M10-male	G1/4-male	G1/4-female
Bellows vacuum cups 1.5 folds - SV-SB1					
23.016.232._*	270.311 (p.411)	270.312/19 (p.414)	--	--	--
23.030.230._*	--	--	270.177 (p.416)	270.451 (p.426)	270.452 (p.431)
Bellows vacuum cups 2.5 folds - SV-SB2					
21.030.030._*	--	--	270.177 (p.416)	270.451 (p.426)	270.452 (p.431)
21.040.132._*	--	--	--	--	--

* When ordering please add the appropriate material code to item no. You will find it in the foldout. Average holding forces for vacuum cups you will find on page 760



Dimensions

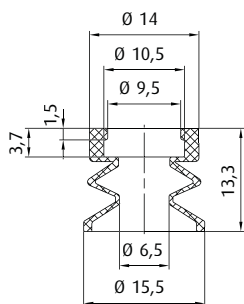

Drawing A

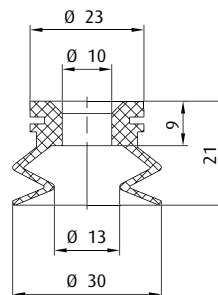

Drawing B

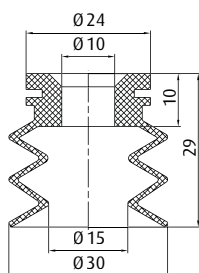

Drawing C

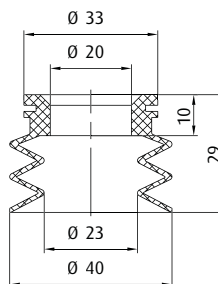

Drawing D

Item no.	Drawing
Bellows vacuum cups 1.5 folds - SV-SB1	
23.016.232._*	A
23.030.230._*	B
Bellows vacuum cups 2.5 folds - SV-SB2	
21.030.030._*	C
21.040.132._*	D

* When ordering please add the appropriate material code to item no. You will find it in the foldout.
Average holding forces for vacuum cups you will find on page 760