

## TRANSFER SYSTEM TSG

MODULAR, ECONOMICAL, STURDY

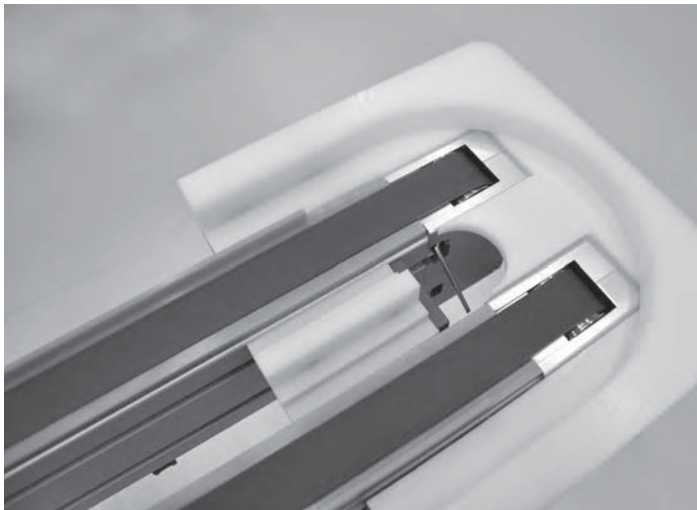

Flexibility in production is gaining more and more importance. Fast and easy adaptation to product development and changed market demands are a decisive factor for success. The TSG transfer system is in keeping with this trend. All the advantages of our construction kit system for machine construction and the precision of our linear system are used in this system. The TSG is completely compatible with the tried and tested MiniTec profile system with workstations, protective devices, conveyor systems, handling equipment, etc. Manual stations and complex automated processes can be achieved cost-effectively with the TSG transfer system.

The TSG consists of standardized modules that can be combined in any number of ways to create tailor-made systems. Robust 25 T5 timing belts with steel reinforcement allow continuous use without the need for re-tensioning. The TSG transfer systems can be supplied as modules for assembly by the customer or as ready-to-use systems including commissioning. We can also take care of the design and layout of the system in accordance with customer specifications. For simple requirements, the checklists in the appendix to this catalog can be used.

#### Technical Data

<b>Speed:</b>	11 m/min
<b>Motor nominal power:</b>	120 W
<b>Nominal voltage</b> (without Frequency transformer):	400 V/50 Hz
<b>Nominal voltage</b> (with Frequency transformer):	230 V/50 Hz
<b>Nominal current:</b>	0,29 A
<b>Drive speed:</b>	64 1/min
<b>Drive torque:</b>	13 Nm
<b>Distributed load:</b>	1710 N
<b>Ambient temperature:</b>	0° bis 50°C

Other speeds are available from 5.5 to 21 m/min. The maximum distributed load is 1710 N. At speeds greater than 11 m/min the maximum distributed load is reduced.

# TRANSFERSYSTEM TSG

## SYSTEM CONCEPTS

### Vertical circuit

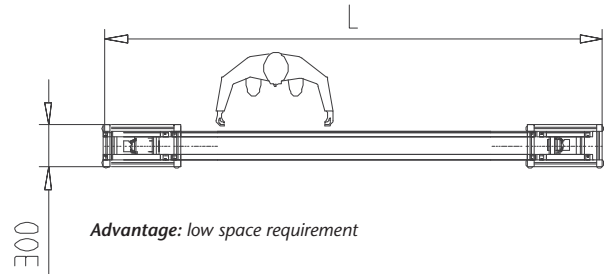
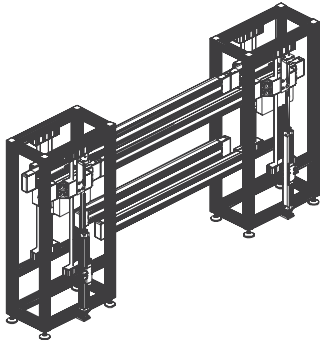

### Basic loop 90°

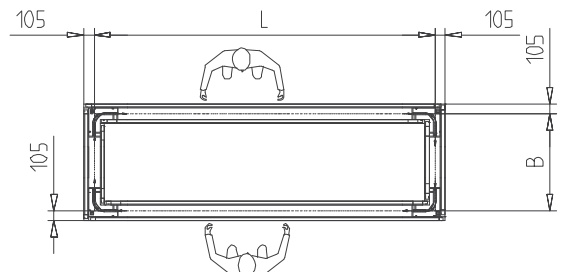
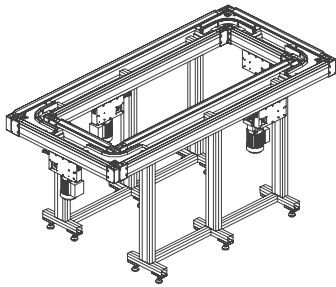

### Compact circuit 180°

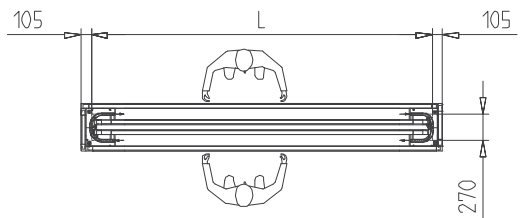
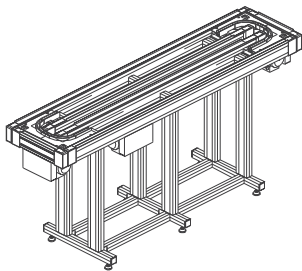

### U-circuit with lifting station

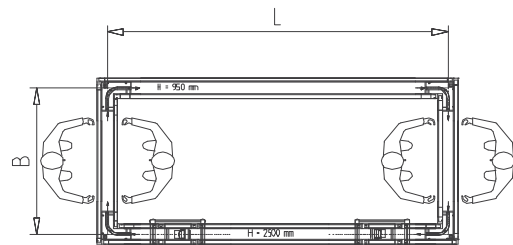
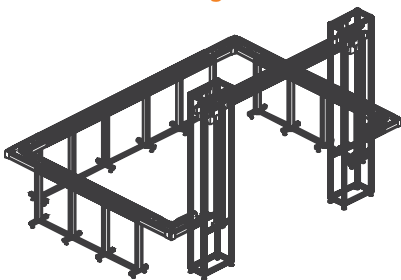

## TRANSFERSYSTEM TSG

### SYSTEM CONCEPTS

#### Double-U circuit

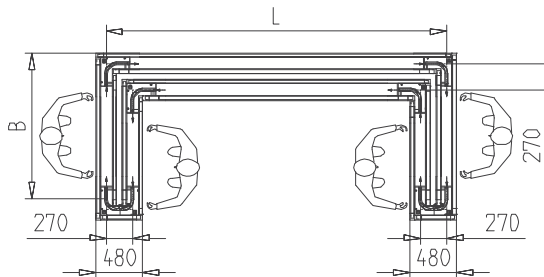
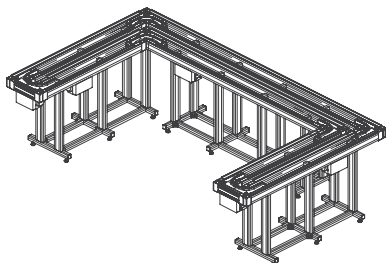

*Advantage: optimal use of area, accessibility to entire conveyor line*

#### Shunt

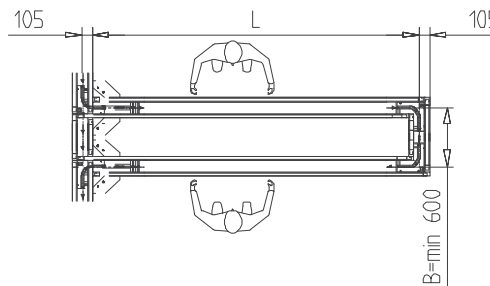
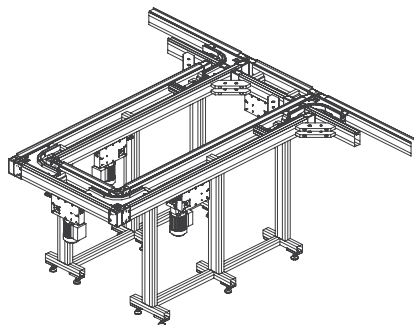

*Advantage: Diversion from main cycle, great flexibility for adaptation and capacity*

#### Combination of different variants

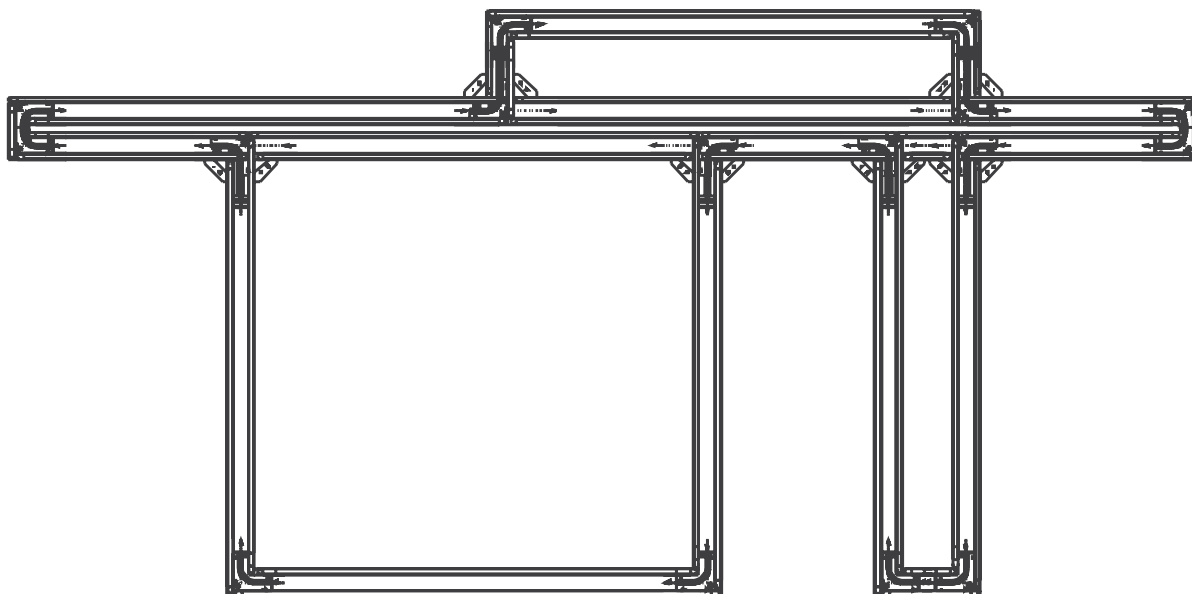

*Advantage: optimal use of space, accessibility to entire conveyor line*

## BASIC LINE

part no. 43.0020/0

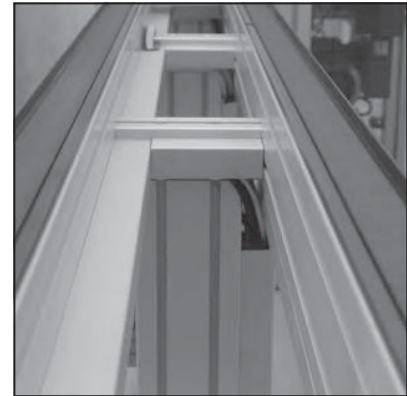
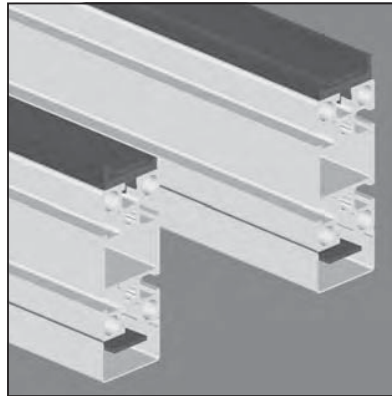
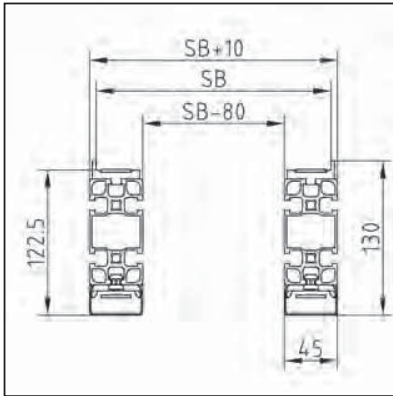

### TECHN. DATA / ITEMS SUPPLIED

- Profile 45 x 90 anodized, E6/EV1 with 4 integrated pneumatic lines
  - Slide strip, PE, black, highly abrasion resistant, Lmax: 2 m
  - Cover profile for belt with clip attachment
  - Track width: 200 mm
  - Line length according to specification
- |                    |                         |
|--------------------|-------------------------|
| - Ix =             | 112,823 cm <sup>3</sup> |
| - Iy =             | 28,526 cm <sup>3</sup>  |
| - Weight           | 3,667 kg/m              |
| - Line length min. | 270 mm                  |
| - Line length max. | 4000 mm                 |

### APPLICATIONS

- Use in all TSG transfer systems
- Max. line load depends on drive concept
- When exceeding the total load per section, please divide into several sections

### ASSEMBLY

- Bolt basic line with supports
- After attachment of drive unit, diversions and timing belts, clip cover profile onto underside of profile
- Free profile grooves for attaching stoppers, sensors, switches, ect. With standard screws

## BASIC MODULE 200

part no. 43.0010/0

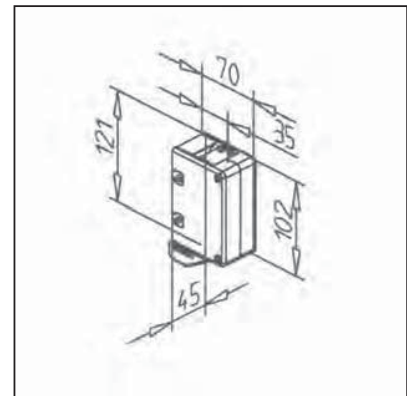
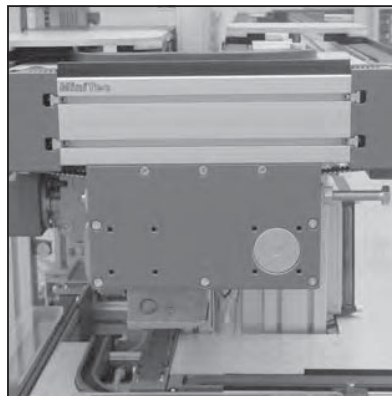
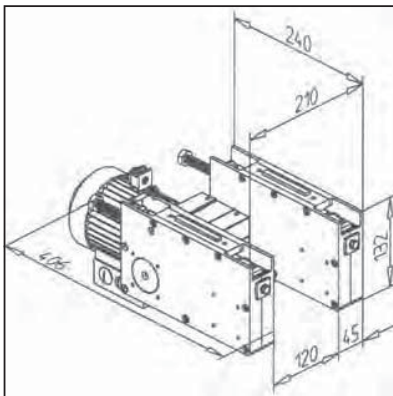

### TECHN. DATA / ITEMS SUPPLIED

- Drive unit with integrated belt tensioners comprising 2 belt drives with connecting shaft and 1 motor
- 4 timing belt reverse units for 25 T5 timing belt
- Track width 200 mm

### APPLICATIONS

- All TSG transfer systems with 25 T5 timing belt

### ASSEMBLY

- Remove drive unit cover
- Screw drive unit securely with attachment set centrally on the bottom of the basic line
- Remove covers from reverse units
- Attach reverse units with profile connectors to ends of the basic line
- Insert timing belt
- Install cover of drive units and reverse units
- Tighten timing belt
- Easy re-tightening of timing belt at drive unit, without prior disassembly, also during operation

## BASIC MODULE VARIABLE

part no. 43.0011/0

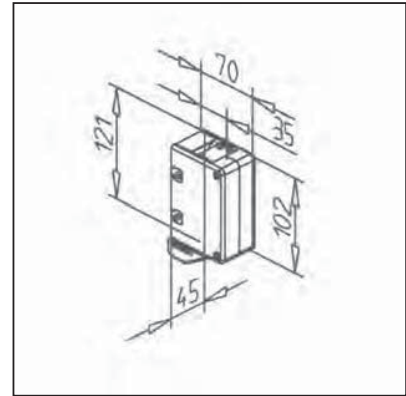
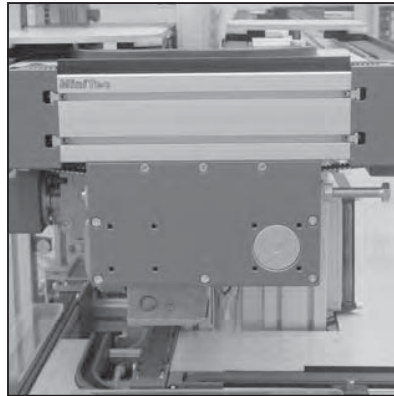
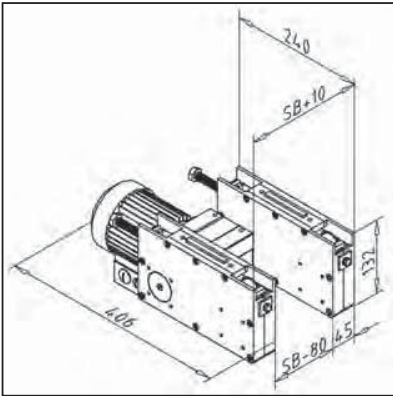

### TECHN. DATA / ITEMS SUPPLIED

- Drive unit with integrated belt tensioners comprising 2 belt drives with connecting shaft and 1 motor
- 4 timing belt reverse units for 25 T5
- Please specify the desired track width

### APPLICATIONS

- Transfer systems with deviant track width
- Width according to dimension L of basic line

### ASSEMBLY

- Remove drive unit cover
- Screw drive unit securely with attachment set centrally on the bottom of the basic line
- Remove covers from reverse units
- Attach reverse units with profile connectors to ends of the basic line
- Insert timing belt
- Install cover of drive units and reverse units
- Tighten timing belt
- Easy re-tightening of timing belt at drive unit, without prior disassembly, also during operation
- Base frames, 90° units and workpiece tray on request

## BASIC BASEFRAME 200

part no. 43.0030/0

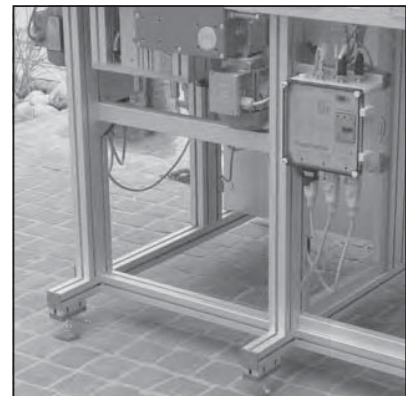
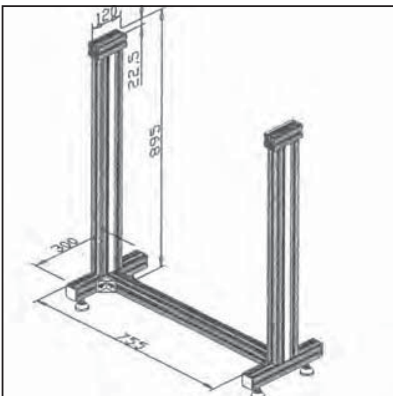

### TECHN. DATA / ITEMS SUPPLIED

- Profile 45 x 45 F, completely assembled
- With fastening kit for connection with basic line
- 4 height-adjustable feet
- Create longer lines with additional add-on supports
- Height 895 mm for standard working height of 950 mm
- Length 755 mm for line length of 1000 mm

### APPLICATIONS

- Substructure for transfer systems with standard working height of 950 mm
- Suitable for track width 200

### ASSEMBLY

- Assemble transverse profile with mounting angles at lower profile groove between basic line
- Secure to floor with angles and floor anchors

## EXTENSION BASEFRAME 200

part no. 43.0040/0

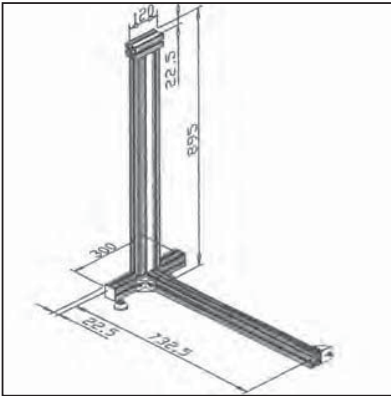

### TECHN. DATA / ITEMS SUPPLIED

- Profile 45 x 45 F, completely assembled
- With fastening kit for connection with basic line and base support
- 2 adjustable feet
- Height 895 mm for standard working height of 950 mm

### APPLICATIONS

- Substructure for transfer systems with standard working height of 950 mm
- Suitable for track width 200

### ASSEMBLY

- Create lengthwise connection with base support
- Assemble transverse profile L= 120 mm with attachment angles at lower profile groove between basic line
- Secure to floor with angles and floor anchors

## CURVE 90° 200

part no. 43.0050/0

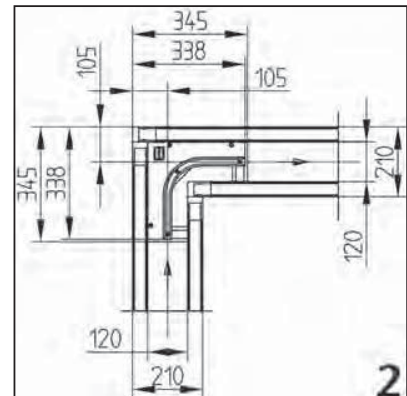
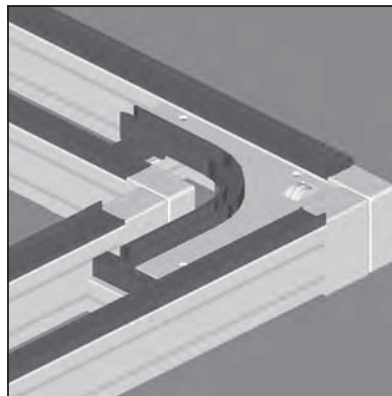
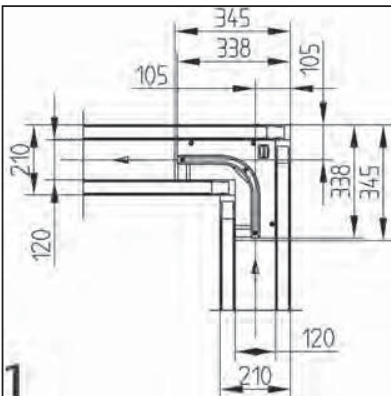

### TECHN. DATA / ITEMS SUPPLIED

- 1 Traverse
- Friction wheel with drive roller
- Curvilinear guide made of PE
- Cover , AL
- Fastening kit

### APPLICATIONS

- No separation before the curve required
- Manufacture of compact transfer systems, shunts and combined system concepts
- Suitable for track width 200

### ASSEMBLY

- Install friction wheel at timing belt reverse unit (on the feed side in transport direction)
- Assemble corners with curvilinear guide
- Screw on cover
- Through appropriate assembly design 1, alternative design 2 can be produced

## CURVE 180° 200

part no. 43.0060/0

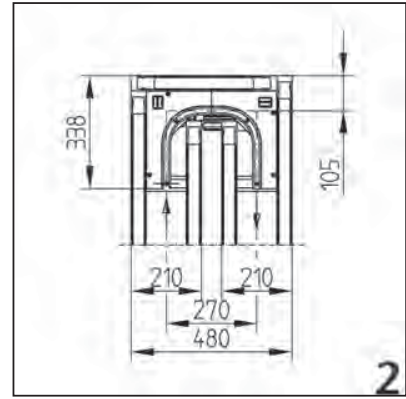
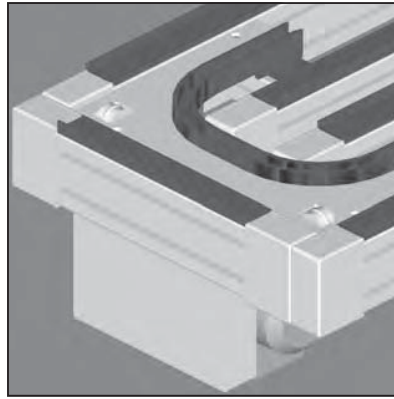
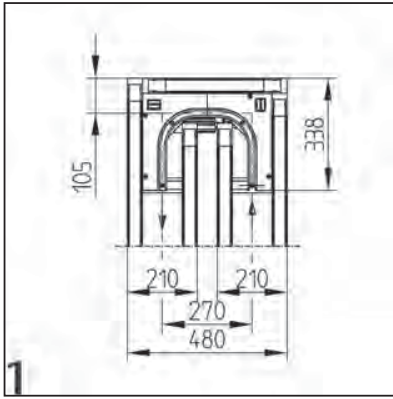

### TECHN. DATA / ITEMS SUPPLIED

- 1 transverse line with drive module, motor assembled
- Corners 180 with curvilinear guide of PE
- 2-part cover
- Friction wheel drive roller
- Fastening kit

### APPLICATIONS

- No separation before the curve required
- Manufacture of compact transfer systems, shunts and combined system concepts
- Suitable for track width 200

### ASSEMBLY

- Install friction wheel at timing belt reverse unit (on the feed side in transport direction)
- Assemble corner 180 with curvilinear guide
- Install transverse line with assembled drive module
- Fasten on cover
- Through appropriate assembly design 1, alternative design 2 can be produced

## STOPPER

part no. 43.1510/0

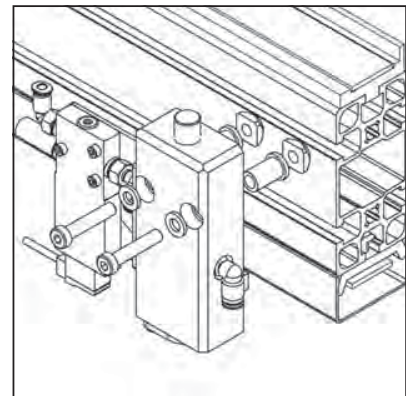
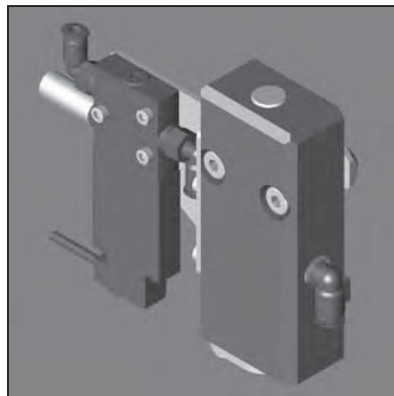
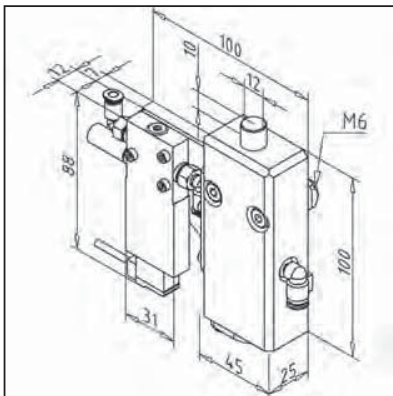

### TECHN. DATA / ITEMS SUPPLIED

- Pneumatically actuated
- PE housing, black
- Stop pins  $\varnothing$  12 mm of tempered stainless steel
- Cylinder and valves integrated
- Prepared for connection to internal air supply
- Fastening kit

### APPLICATIONS

- Separation of workpiece trays before infeed and discharge, lift or lift stations
- Control of priorities in WT flow

### ASSEMBLY

- Screw onto inside of transport line at upper profile groove
- Make connection to air supply
- Position can be adjusted horizontally
- Separation of tray's by combination of 2 stoppers

## PROXIMITY SWITCH

part no. 43.0090/0

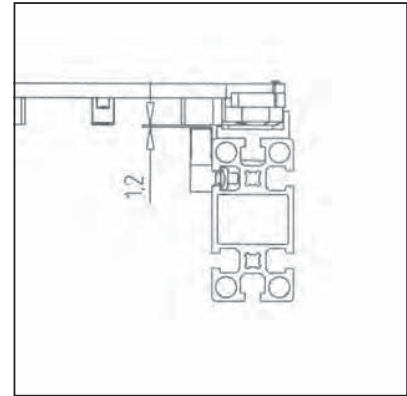
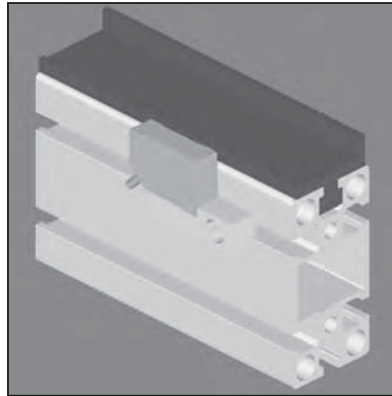
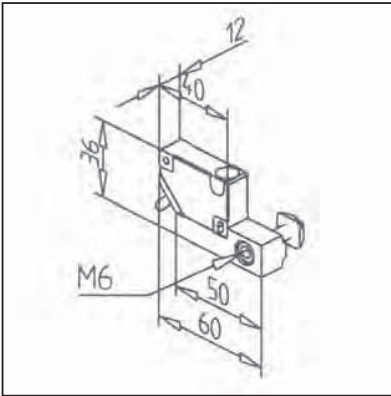

### TECHN. DATA / ITEMS SUPPLIED

- inductive proximity switch design PNP "closer"
- Switching distance 4 mm
- Cubic, plastic PBTp
- Operating voltage (V)     Okt 36 DC
- Continuous current load     250 mA
- protection degree             IP 67
- Fastening kit

### APPLICATIONS

- Switching operations
- Control of system states before lift stations and stoppers

### ASSEMBLY

- Screw onto inside of transport line at upper profile groove
- Position can be adjusted horizontally

## SWITCH UNIT OUT 200

part no. 43.0073/0

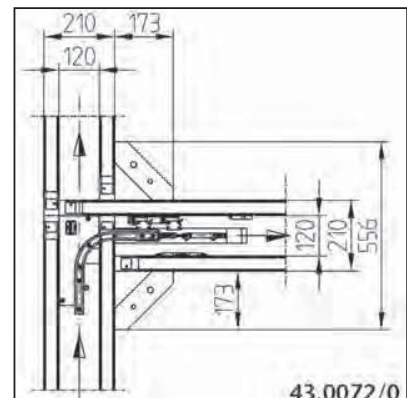
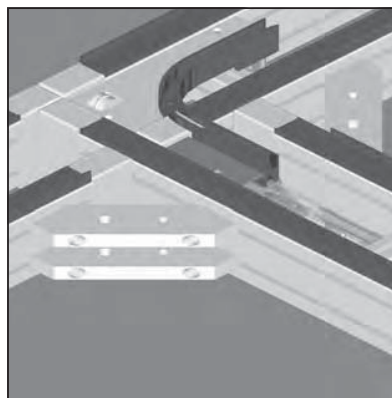
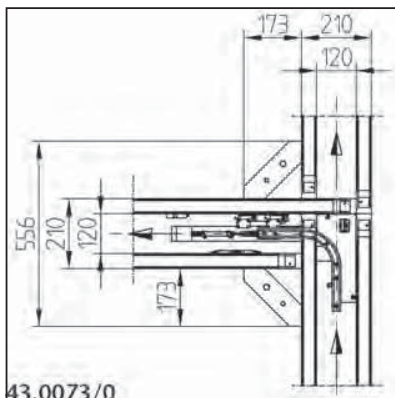

### TECHN. DATA / ITEMS SUPPLIED

- Pneumatically actuated
- Carrier profile 45 x 45
- WT-guide 2 parts, PE
- Cover AL
- Friction wheel with drive roller
- 2 Pneumatic cylinders
- 4 corners 180
- Fastening kit

### APPLICATIONS

- Divert Workpiece trays from basic circuit to secondary lines
- Separation of work procedures from machine cycle
- Inserting further processing stations
- Forming storage units
- When discharge is active, WT is diverted from the line by 90° into a transverse transport. The orientation of the WT is not changed
- If the chute is inactive, the WT remains in the basic circuit
- Status query of the chute via the sensor
- suitable for track width 200

### ASSEMBLY

- 1) Switch unit left **part no. 43.0073/0**
- 2) Switch unit right **part no. 43.0072/0**
- Install friction wheel on belt return unit (in transport direction, on the longer side of the line)
- Install pneumatic cylinder
- Attach curve guide
- Screw on cover
- Connect transverse transport with corners and aling
- Connect pneumatic cylinder to compressed air supply



## SWITCH UNIT IN 200

part no. 43.0071/0



43.0071/0

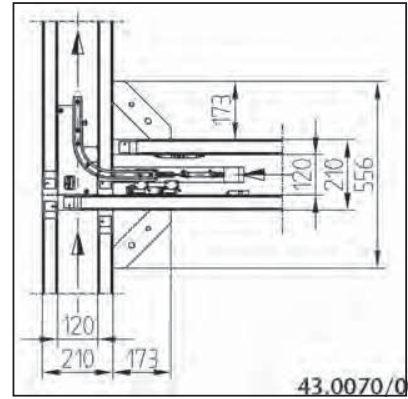
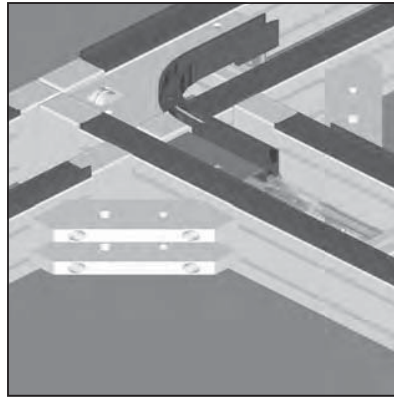

43.0070/0

### TECHN. DATA / ITEMS SUPPLIED

- Pneumatically actuated
- Carrier profile 45 x 45
- WT-guide 2-piece, PE
- Cover PE
- Friction wheel with drive roller
- 2 Pneumatic cylinders
- 4 corners 180
- Fastening kit

### APPLICATIONS

- Feed WHs from secondary lines back into the basic circuit.
- Separation of work procedures from machine cycle
- Inserting further processing stations
- Forming storage units
- If infeed is active, the WH is diverted from the secondary line to the basic circuit
- The orientation of the WH is not changed. Status query of the chute via the sensor
- suitable for track width 200

### ASSEMBLY

- 1) Switch unit left **part no. 43.0071/0**
- 2) Switch unit right **part no. 43.0070/0**
- Install friction wheel on belt return unit (in transport direction, on the longer side of the line)
- Install pneumatic cylinder
- Attach curve guide
- Screw on cover
- Connect transverse transport with corners and aling
- Connect pneumatic cylinder to compressed air supply

## WORKPIECE TRAY 200

part no. 43.1000/0

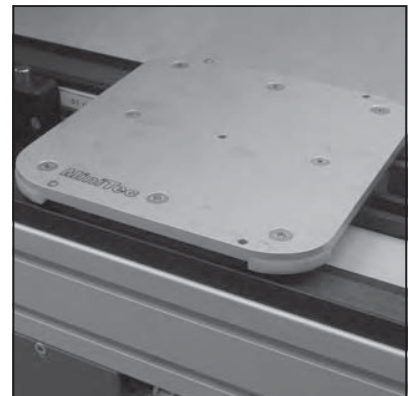
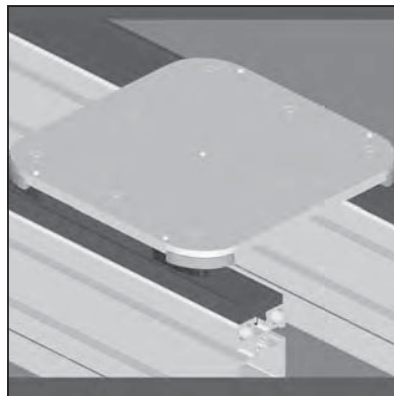
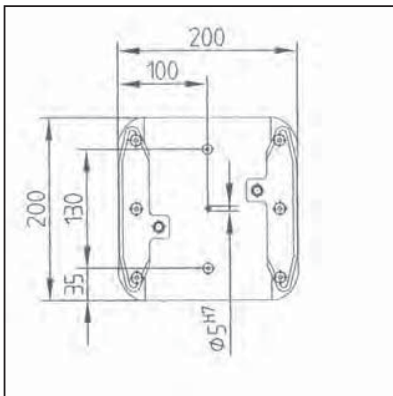

### TECHN. DATA / ITEMS SUPPLIED

- Carrier plate Al, progressed on all sides and anodized with centering hole 5H7
- 4 positioning pins, st
- Shoes of highly abrasion-resistant PE, with integrated stop for stopper
- 2 damping pins, st, for proximity
- Size 200 x 200 mm
- Load max. 100 N
- Weight 1 kg

### APPLICATIONS

- Holding workpieces, jigs, identification, and data storage systems

### ASSEMBLY

- Standard-WTs are delivered without holder holes
- Attachment holes for workpieces, mechanisms, and identification systems are created according to customer specifications

## POSTIONER 200

part no. 43.0110/0

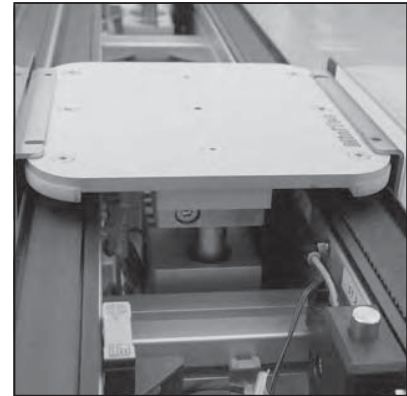
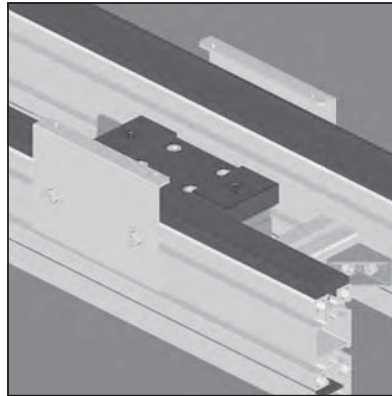
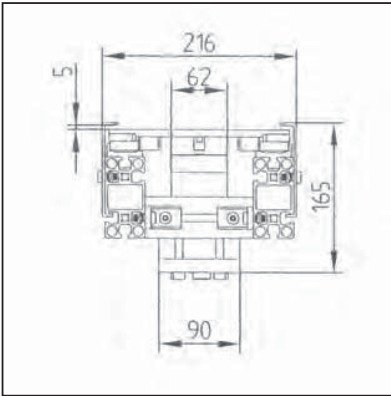

### TECHN. DATA / ITEMS SUPPLIED

- Ready-for-use module with doubledacting pneumatic cylinder and valve
- WT receptacle mounted
- 2 overhead grip strips, galvanized steel
- Load max. 1000 N
- Positioning precision  $\pm 0,03$  mm
- Lift height belt 5 mm

### APPLICATIONS

- Exact positioning of workpieces on the workpiece tray for processing or inspection

### ASSEMBLY

- Attach lift unit to line profiles with included Fastening kit
- Screw overhead grip strips to outside of line, align exactly with positioner
- Make connection to internal compressed air supply
- Suitable stopper **part no. 43.1510/0** and proximity switch **part no. 43.0090/0**

## LIFT STATION 200

part no. 43.0100/0

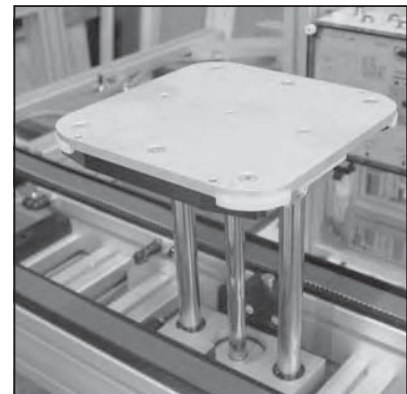
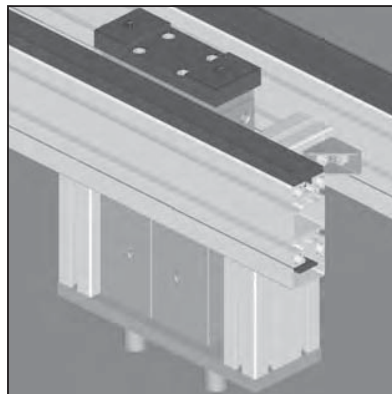
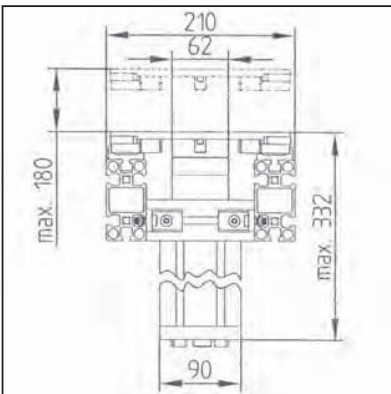

### TECHN. DATA / ITEMS SUPPLIED

- Ready-for-use module with doubledacting pneumatic cylinder and valve
- WT receptacle mounted
- Lift height: Can be set from 5 mm to 180 mm above belt
- Load max. 1000 N

### APPLICATIONS

- Positioning of workpieces on the workpiece tray for processing or inspection

### ASSEMBLY

- Attach lift station to line profiles with included Fastening kit
- Make connection to internal compressed air supply
- Suitable stopper **part no. 43.1510/0** and proximity switch **part no. 43.0090/0**

## ELEVATOR STATION 200

part no. 43.0080/0

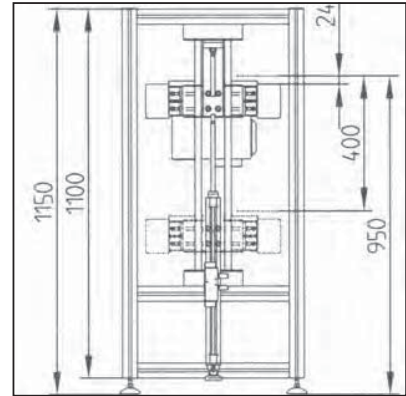
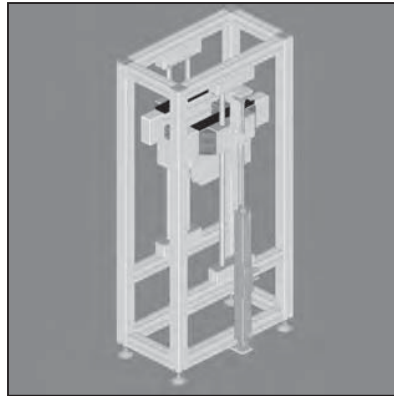
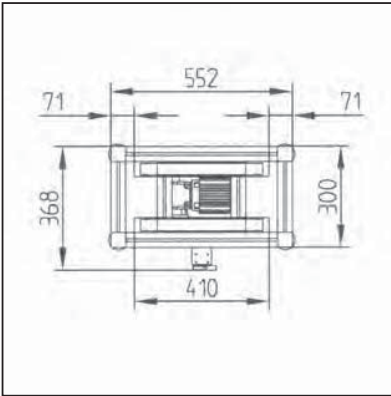

### TECHN. DATA / ITEMS SUPPLIED

- Ready-for-use assembled module according to customer specification  
Frame structure profiles 45 x 45
- Frame installation off construction profiles 45 x 45
- on skid mounted, powered dual track road
- Skid proceed with double-acting pneumatic cylinder
- Stable guidance of the skid with Ø 20 mm precision shafts and linear units LB series
- Lift height variable according to customer specification
- Load max. 480 N

### APPLICATIONS

- Transport rollers at any length for driven or non-driven roller conveyors

### ASSEMBLY

- Please indicate needed tube length
- Align lift station with transport levels

## TIMING BELT

part no. 43.1411/0

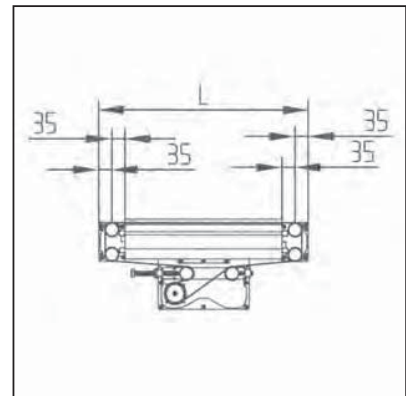
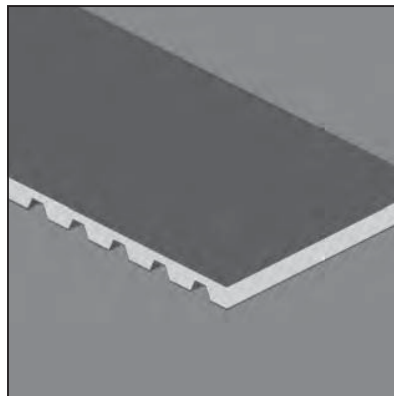
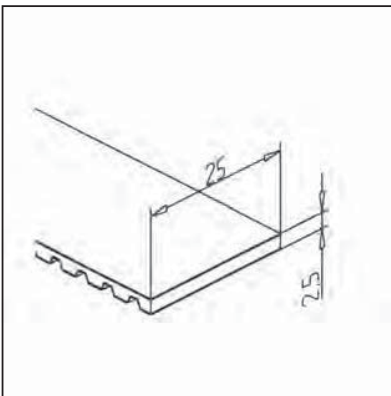

### TECHN. DATA / ITEMS SUPPLIED

- Endless belt, reinforced with steel insert
- Covered with plastic fabric on both sides to improve sliding characteristics and reduce friction
- Colour: green
- Applications

### APPLICATIONS

- All transfer systems TSG
- Calculation formula for timing belt length:  
Total = (L - 70) x 2 + 473 mm, round up 5 mm

### ASSEMBLY

- PVC, grey
- Remove lower belt cover (clip lock)
- Remove cover of drive unit and timing belt reverse units
- Insert belt
- Install cover and belt cover
- Tighten timing belt

TRANSFERSYSTEM TSG

REQUEST VERTICAL CIRCUIT TSG 200

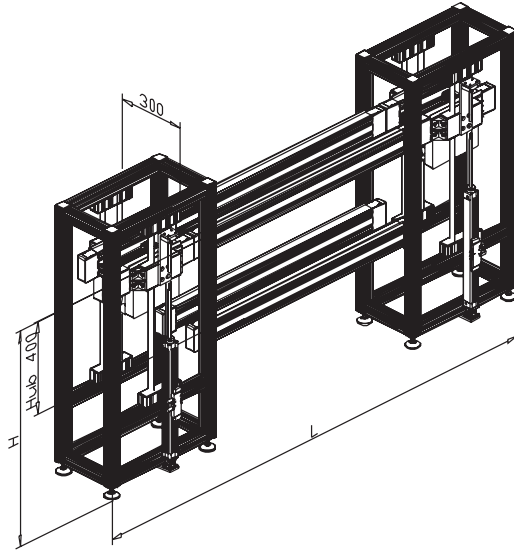

Dimension L  mm

Working height H (WT-Upper edge)  mm

Number of stoppers  Pieces

Number of positioners  Pieces

Number of elevator stations  Pieces

Direction of transport  right  left

Speed  m/min

Frequency transformer  yes  no

Controller

Number of sensors  Pieces

Contact details

Company   Please call me back

Contact person   Please send me an offer

Phone no.

Fax no.

E-Mail

# TRANSFERSYSTEM TSG

## REQUEST BASIC CIRCUIT 90° TSG 200

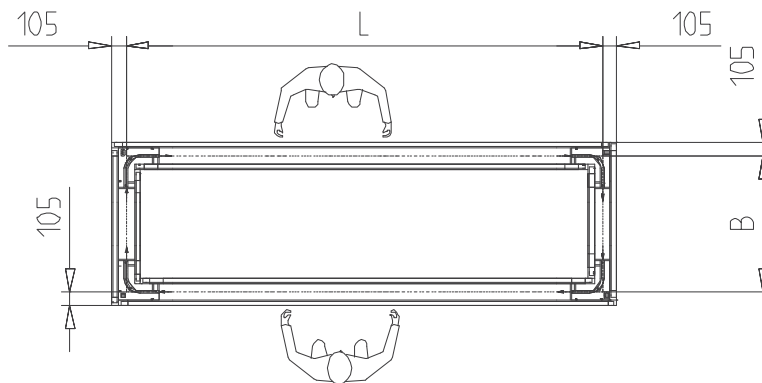
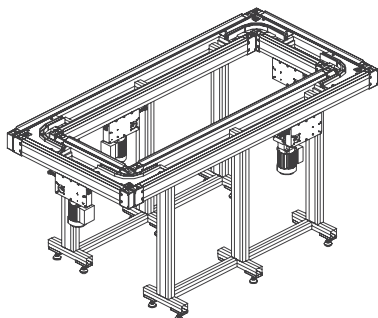

Dimension L x B  mm

Working height H (WT-Upper edge)  mm

Number of stoppers  Pieces

Number of positioners  Pieces

Number of elevator stations  Pieces

Direction of transport  right  left

Speed  m/min

Frequency transformer  yes  no

Controller

Number of sensors  Pieces

**Contact details**

Company   Please call me back

Contact person   Please send me an offer

Phone no.

Fax no.

E-Mail

TRANSFERSYSTEM TSG

REQUEST COMPACT CIRCUIT 180° TSG 200

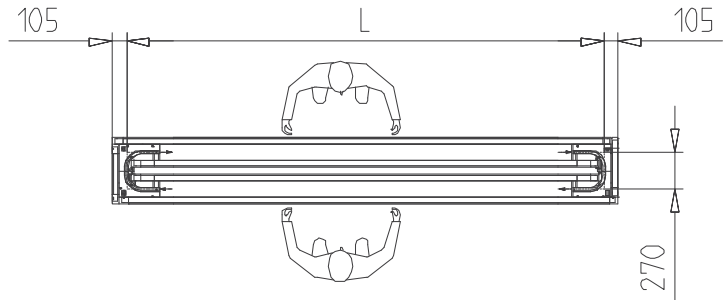
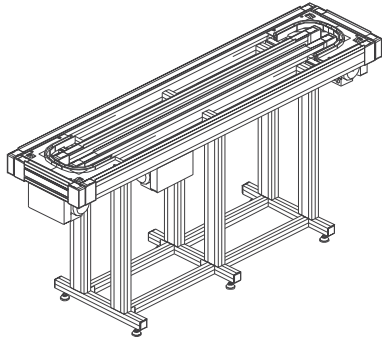

Dimension L x B  mm  mm

Working height H (WT-Upper edge)  mm

Number of stoppers  Pieces

Number of positioners  Pieces

Number of elevator stations  Pieces

Direction of transport  right  left

Speed  m/min

Frequency transformer  yes  no

Controller

Number of sensors  Pieces

Contact details

Company   Please call me back

Contact person   Please send me an offer

Phone no.

Fax no.

E-Mail

# TRANSFERSYSTEM TSG

## REQUEST U-CIRCUIT WIHT ELEVATOR STATIONS TSG 200

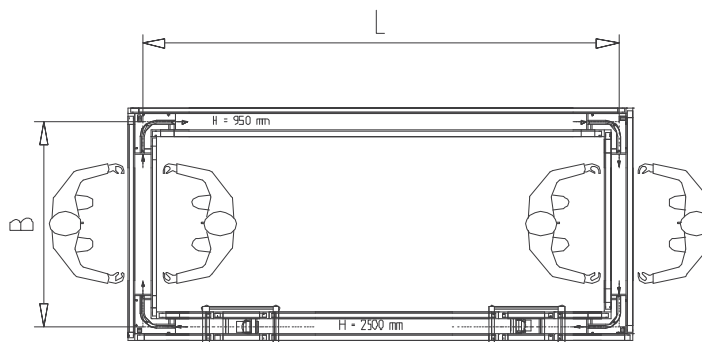
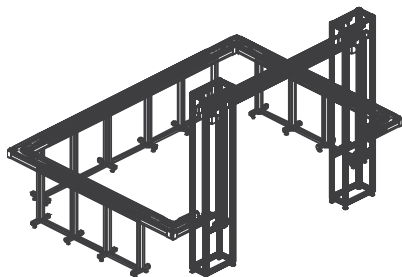

Dimension L x B  mm

Working height H (WT-Upper edge)  mm

Number of stoppers  Pieces

Number of positioners  Pieces

Number of elevator stations  Pieces

Direction of transport  right  left

Speed  m/min

Frequency transformer  yes  no

Controller

Number of sensors  Pieces

**Contact details**

Company   Please call me back

Contact person   Please send me an offer

Phone no.

Fax no.

E-Mail

TRANSFERSYSTEM TSG

REQUEST DOUBLE-U-CIRCUIT TSG 200

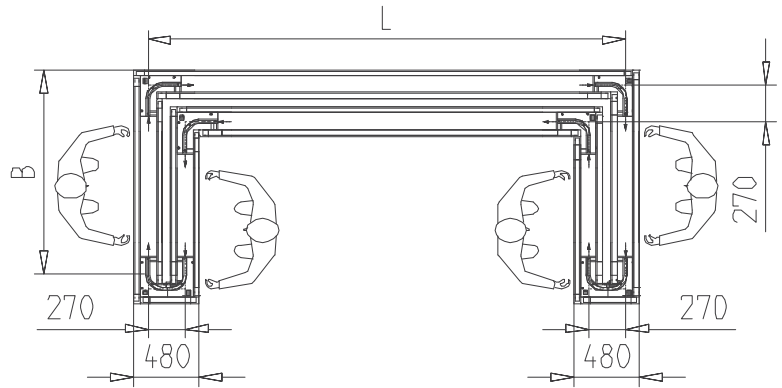
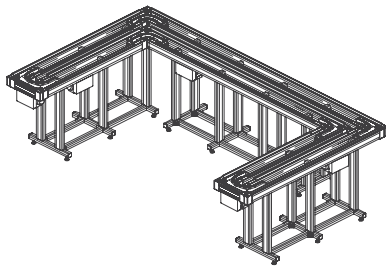

Dimension L x B  mm  mm

Working height H (WT-Upper edge)  mm

Number of stoppers  Pieces

Number of positioners  Pieces

Number of elevator stations  Pieces

Direction of transport  right  left

Speed  m/min

Frequency transformer  yes  no

Controller

Number of sensors  Pieces

Contact details

Company   Please call me back

Contact person   Please send me an offer

Phone no.

Fax no.

E-Mail



# TRANSFERSYSTEM TSG

## REQUEST SHUNT TSG 200

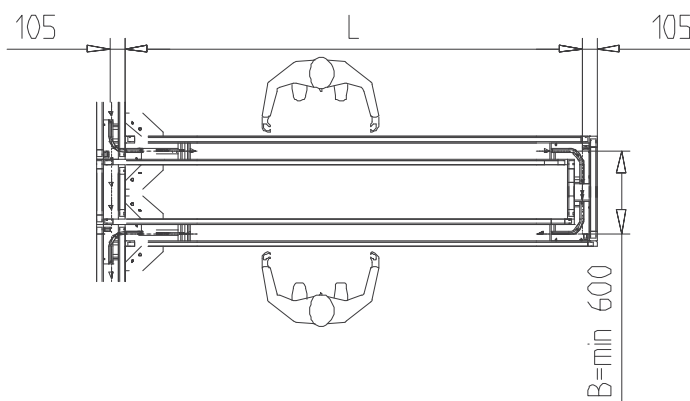
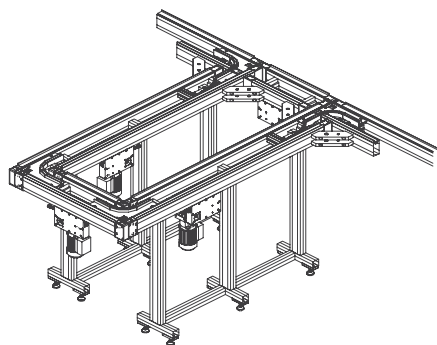

Dimension L x B  mm  mm

Working height H (WT-Upper edge)  mm

Number of stoppers  Pieces

Number of positioners  Pieces

Number of elevator stations  Pieces

Direction of transport  right  left

Speed  m/min

Frequency transformer  yes  no

Controller

Number of sensors  Pieces

**Contact details**

Company   Please call me back

Contact person   Please send me an offer

Phone no.

Fax no.

E-Mail