

WORKSTATIONS

The workstation belongs to the standard equipment in the productive areas of many companies. Due to its flexible, ergonomic and goal-oriented Design is the basis for extremely economical flexible workstation systems. On the next pages we introduce the different worktable models.



BASIC WORKSTATIONS

Individual. The MiniTec workstations from the modular system.

MiniTec offers you different base frames with or without portal construction. You can either define the dimensions yourself or use standard variants with given dimensions.

Workstation



Workstation L with portal



Workstation S with reinforced portal construction



Sample application

Sample application

Sample application

		Workstations			
		Preferred dimensions			
Width (B)	variable	1000	1200	1500	2000
Depth (T)	variable	700			
Depth (T1)	variable	555			
Height (H)	variable	678			
Height (H1)	variable	2100			
Height (H2)	variable	100			
max. load capacity [N] Type L/S	variable	1500	1000	800	800/1200
Workstation	32.0111/0	32.0111/1	32.0111/2	32.0111/3	32.0111/4
Workstation L with portal	32.0112/0	32.0112/1	32.0112/2	32.0112/3	32.0112/4
Container table S with portal	32.0113/0	32.0113/1	32.0113/2	32.0113/3	32.0113/3

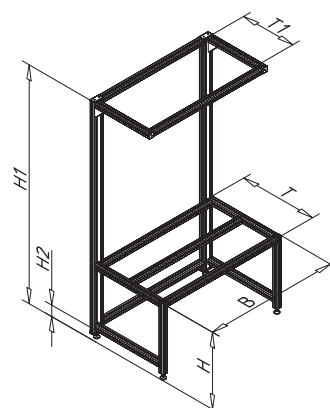
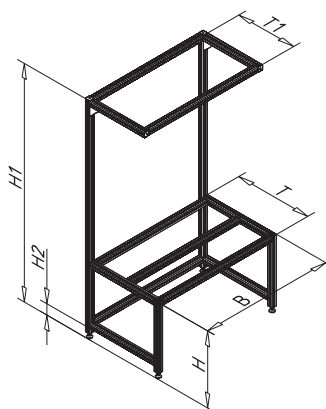
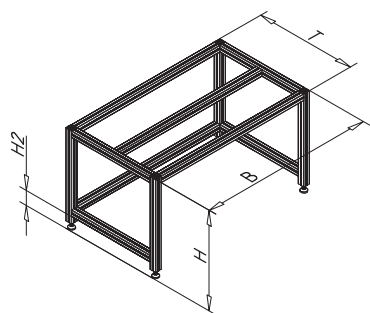

- Our basic workstations are available without a portal, with portal or reinforced portal
- The base frame of our workstations consists of the profile 45 x 45 F, anodised E6 /EV1.
- The frame is mounted electrically conductive with the MiniTec power-lock fastener.
- To compensate for uneven floors, the bases are equipped with articulated feet PA, spindle M10 plate Ø45mm.
- The racks are supplied without Tabletops and the necessary mounting brackets for tabletops.
- The workstation S with portal has a reinforced portal structure and can be loaded more heavily with a table width of 2000mm