

## EQUIPMENT

In the day-to-day life it is the small things that matter. Practical accessories are the necessary supplement to the perfect design of an optimal workplace. Everything must have its place, instructions or information must be clean and visible. Additional

devices that avoid stress and provide an overview in the workplace help to noticeably increase efficiency while reducing the workload of employees.

## SYSTEM WORKSTATION COMPONENTS

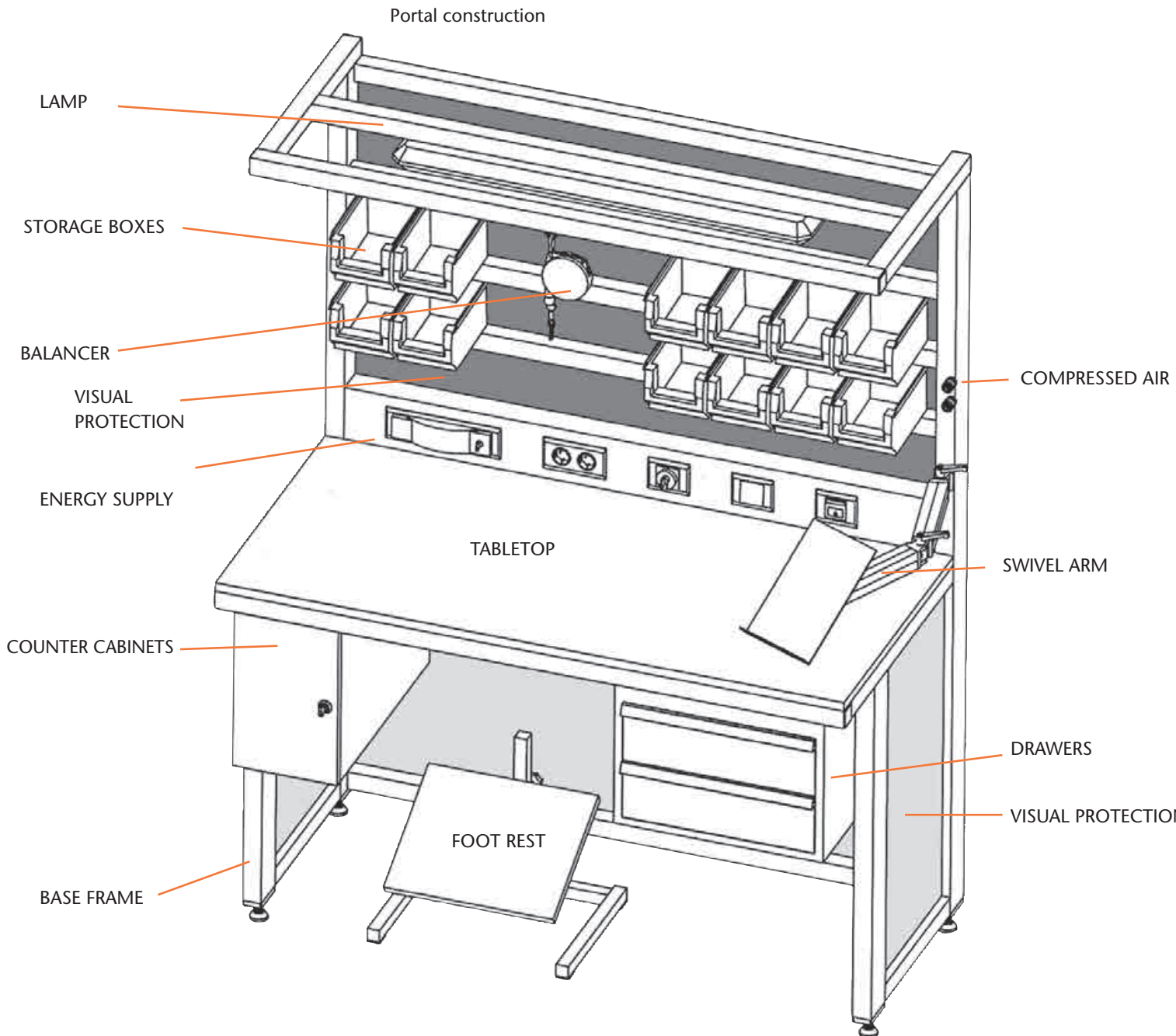

EQUIPMENT

■ For overview and order in the workplace

With the MiniTec assortment of tool holder plates, tool carriers and various tool holders, you can create an overview and order at your workplace. With this program, the operator has the right holder for every tool.

Tool holder plates

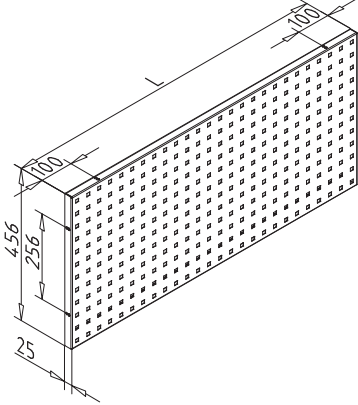
		Tool holder plates	
		Size 500:	L = 494 mm
		Part No.	32.0660/0
		Size 1000:	L = 988 mm
		Part No.	32.0665/0
		Size 1200:	L = 1178 mm
		Part No.	32.0670/0
		Size 1500:	L = 1482 mm
		Part No.	32.0675/0
		Size 2000:	L = 1976 mm
		Part No.	32.0680/0

- Steel, powder coated, grey, RAL 7035
- ESD capability
- Is simply attached to the portal structure
- Square perforation 10 x 10mm in grid 38mm

Tool carrier with double-joint swivel arm

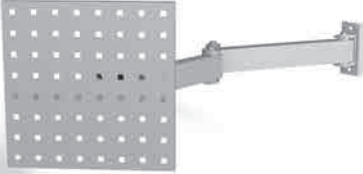
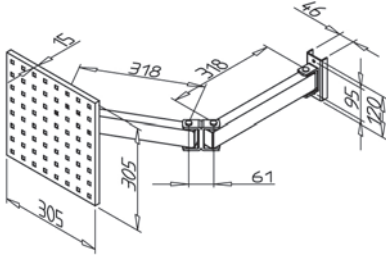

		Tool carrier with double joint swivel arm	
		Part no.	32.0510/0
		ESD tool carrier with double joint swivel arm	
		Part no.	32.0510/6

- Steel, painted light grey, RAL 7035
- Capacity 150 N
- Is simply attached to the portal structure
- Square perforation 10 x 10mm in grid 38mm





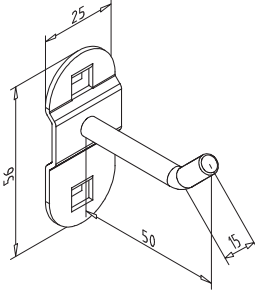
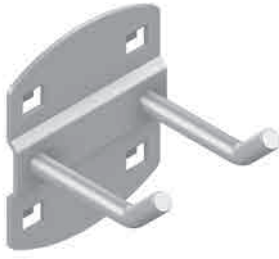
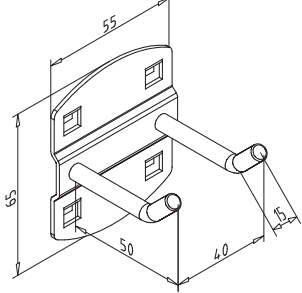
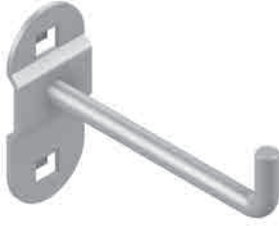
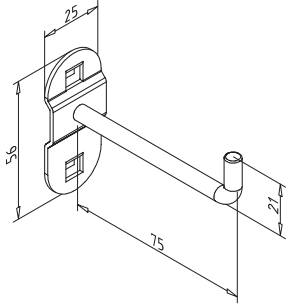

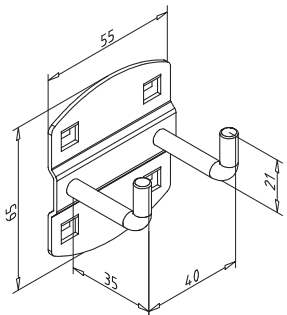
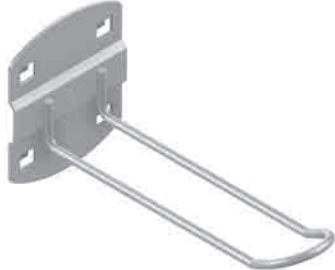
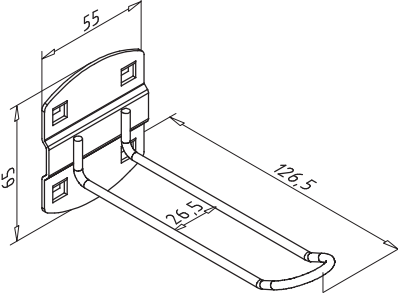

## EQUIPMENT

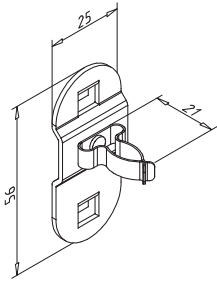
The aluminum-colored tool holders have a shock- and scratch-resistant plastic coating and a 1.5mm thick, embossed base plate. The holders are matched to the tool holder plates and the tool carrier.

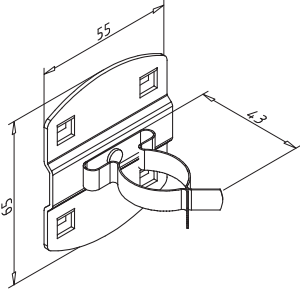

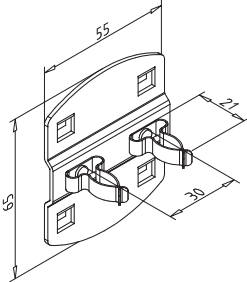

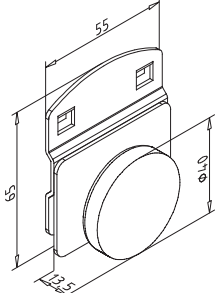

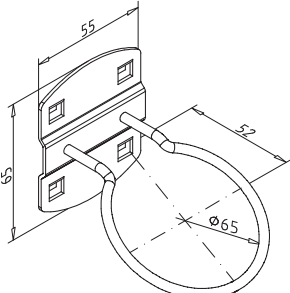

All products are also available in ESD version on request.

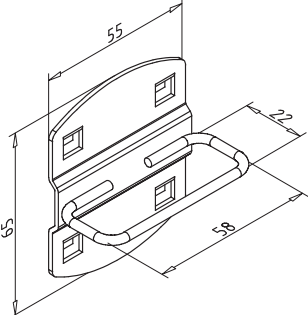
		<p><b>Tool holder with angled hook end</b></p> <p>Hook Ø 6,3 mm</p> <p>L= 50mm      Part No.    32.0527/0</p> <p>L=100mm     Part No.    32.0651/0</p>
		<p><b>Double tool holder with inclined hook end</b></p> <p>Hook Ø 6,3 mm</p> <p>L= 50mm      Part No.    32.0653/0</p> <p>L= 75mm      Part No.    32.0654/0</p>
		<p><b>Tool holder with vertical hook end</b></p> <p>Hook Ø 6,3 mm</p> <p>L= 75mm      Part No.    32.0652/0</p>
		<p><b>Double tool holder with vertical hook end</b></p> <p>Hook Ø 6,3 mm</p> <p>L= 35mm      Part No.    32.0508/0</p> <p>L= 50mm      Part No.    32.0655/0</p> <p>L= 75mm      Part No.    32.0656/0</p>
		<p><b>Tool holder for self-service packaging</b></p> <p>Hanger Ø 3,7 mm</p> <p>L= 125mm, W= 30mm      Part No.    32.0658/0</p>

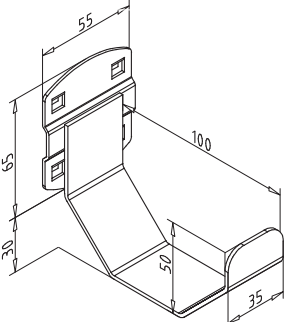

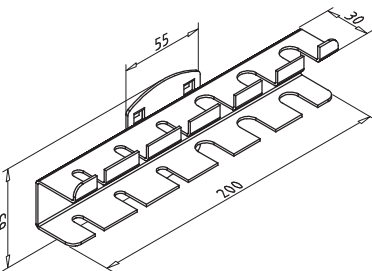

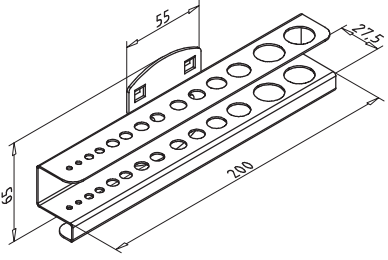

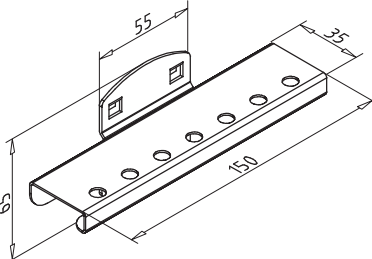

EQUIPMENT

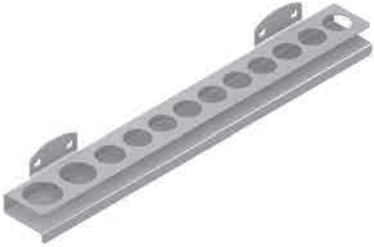
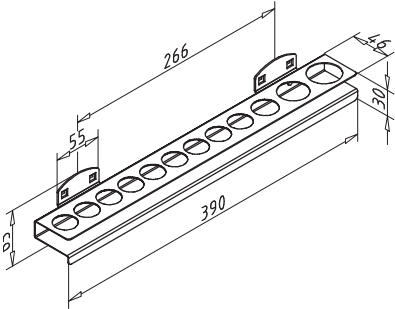
		<p><b>Tool clamp simple, small base plate</b></p> <p>For clamping tools with <math>\varnothing</math> 7-10 mm</p> <p>Part No. 32.0529/0</p>
		<p><b>Tool clamp simple, large base plate</b></p> <p>For clamping tools with <math>\varnothing</math> 20-25 mm</p> <p>Part No. 32.0528/0</p>
		<p><b>Double tool clamp</b></p> <p>For clamping tools with <math>\varnothing</math> 7-10 mm</p> <p>Part No. 32.0506/0</p>
		<p><b>Magnetic holder</b></p> <p>Holding force approx. 5 kg</p> <p>Part No. 32.0515/0</p>
		<p><b>Machine holder</b></p> <p>For tools up to <math>\varnothing</math> 60 mm</p> <p>Part No. 32.0657/0</p>

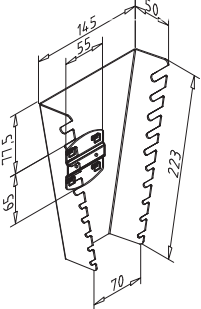

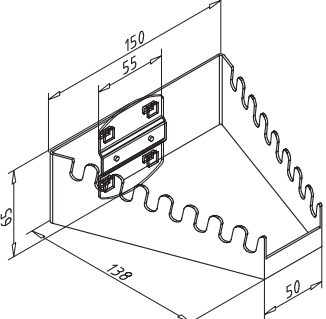
EQUIPMENT

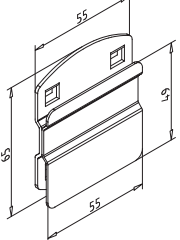
		<p><b>Chuck holder</b></p> <p>For tools with a cross section of up to 54 x 19 mm</p> <p>Part No. 32.0531/0</p>
		<p><b>Pipe holder, also for hoses, cables etc.</b></p> <p>For hoses and cables up to 100 mm in diameter</p> <p>Part No. 32.0564/0</p>
		<p><b>Screwdriver holder for 6 parts</b></p> <p>3 receiving slots 6.5 mm wide and 23 mm deep 3 receiving slots 12.5 mm wide and 23 mm deep</p> <p>Part No. 32.0649/0</p>
		<p><b>Drill / hex socket holder, for 14 parts</b></p> <p>Mounting holes</p> <ul style="list-style-type: none"> <li>2 x Ø 3,2 mm</li> <li>2 x Ø 4,7 mm</li> <li>2 x Ø 6,7 mm</li> <li>2 x Ø 7,7 mm</li> <li>2 x Ø 8,7 mm</li> <li>1 x Ø 10,7 mm</li> <li>1 x Ø 12,7 mm</li> <li>2 x Ø 16,7 mm</li> </ul> <p>Part No. 32.0504/0</p>
		<p><b>Bit holder for 7 bits</b></p> <p>Mounting holes 7x Ø 7,2 mm</p> <p>Part No. 32.0503/0</p>

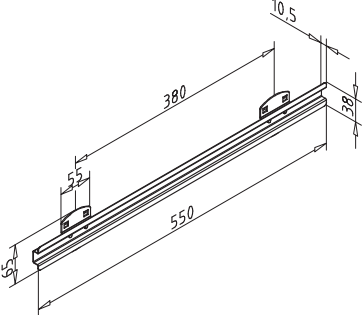
EQUIPMENT

		<p><b>Nut holder for 12 nuts</b></p> <p>Mounting holes</p> <p>9 x Ø 24,7 mm          1 x Ø 27,3 mm          1 x Ø 31,7 mm          1 x Ø 34,7 mm</p> <p>Part No. 32.0519/0</p>
		<p><b>Wrench holder vertical for 10 keys</b></p> <p>Receiving slots</p> <p>1 x 7,5 x 30 mm          2 x 6,5 x 23 mm          2 x 5,5 x 20 mm          2 x 4,5 x 15 mm          3 x 4,0 x 10 mm</p> <p>Part No. 32.0521/0</p>
		<p><b>Wrench holder horizontally for 8 keys</b></p> <p>8 receiving slots 6.5 x 15 mm</p> <p>Part No. 32.0523/0</p>
		<p><b>View storage boxes for 1 box size 7 and 8</b></p> <p>Max. material thickness for hanging 4 mm</p> <p>B= 55mm Part No. 32.0509/0</p>
		<p><b>View storage boxes for 5 boxes up to size 8</b></p> <p>L= 550mm, H= 38mm Part No. 32.0532/0</p>

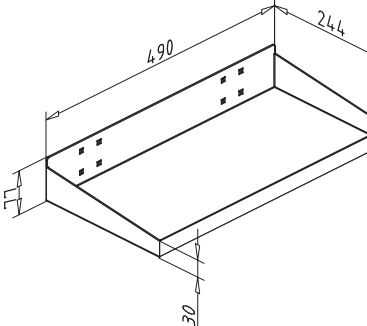
## EQUIPMENT

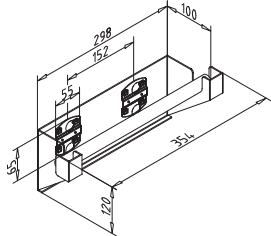
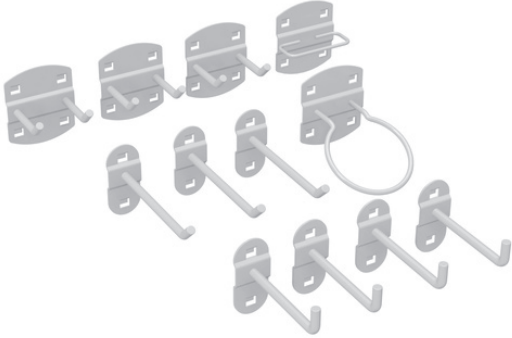
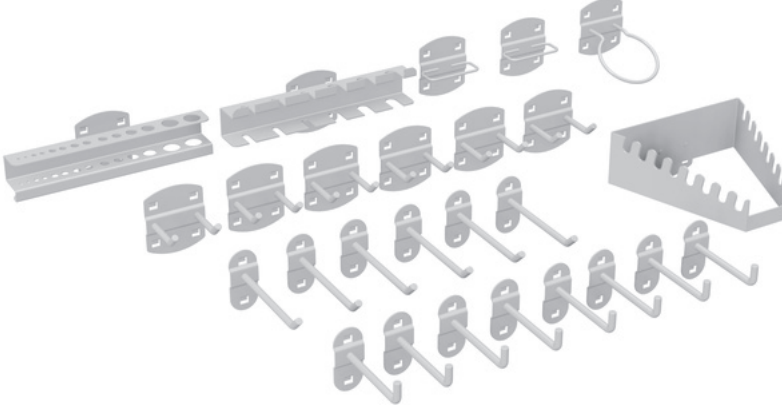
		<p><b>Steel floor with roll-off edge</b></p> <p>W= 490mm, D= 243mm      Part No.      32.0659/0</p>
		<p><b>Dispensers</b></p> <p>Roller axis <math>\varnothing</math> 22 mm Distance between roller axis and rear wall approx. 50 mm</p> <p>Part No.      32.0611/0</p>
	<p><b>Tool holder assortment, 12 pieces</b> <b>Part no. 32.0607/0</b> <b>consisting of:</b></p> <p>4 x Toolholder      Part No.      32.0652/0</p> <p>3 x Toolholder      Part No.      32.0651/0</p> <p>3 x Double tool holder      Part No.      32.0653/0</p> <p>1 x Machine holder      Part No.      32.0657/0</p> <p>1 x Chuck holder      Part No.      32.0531/0</p>	
	<p><b>Tool holder assortment, 26 pieces</b> <b>Part no. 32.0606/0</b> <b>consisting of:</b></p> <p>8 x Toolholder      Part No.      32.0652/0</p> <p>6 x Toolholder      Part No.      32.0651/0</p> <p>6 x Double tool holder      Part No.      32.0653/0</p> <p>1 x Machine holder      Part No.      32.0657/0</p> <p>2 x Chuck holder      Part No.      32.0531/0</p> <p>1 x Screwdriver holders      Part No.      32.0523/0</p> <p>1 x Drill / hex socket holder      Part No.      32.0504/0</p> <p>1 x Screwdriver holders      Part No.      32.0649/0</p>	



**UNIVERSAL HOLDER**

Part no.

22.1175/0

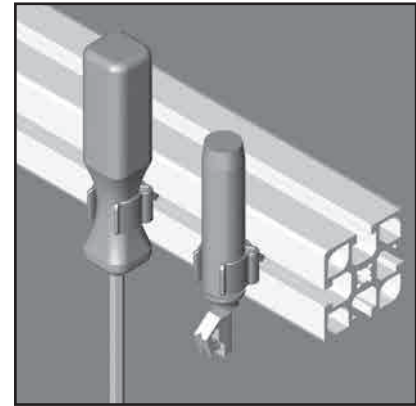
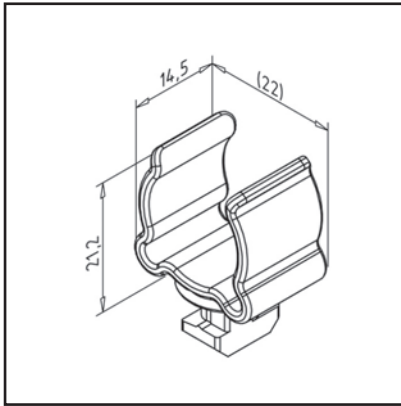
**TECHN. DATA / ITEMS SUPPLIED**

- PA, grey
- Polyamide, grey
- Weight = 0.003 kg/piece

**APPLICATIONS**

- Holding for all kinds of worktools
- Tools with a diameter of ca. 15 - 21 mm
- Max. weight 160 g

**ASSEMBLY**

- Insert in profile groove and turn 90°

**MAGNET 6 X 14 X 50**

Part no.

21.0032/0

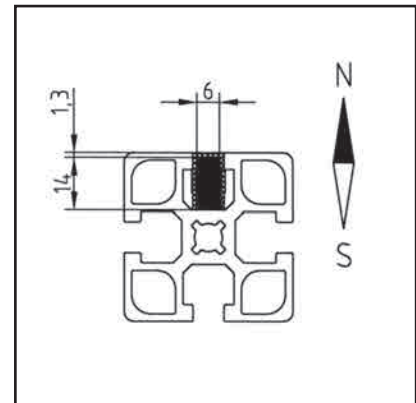
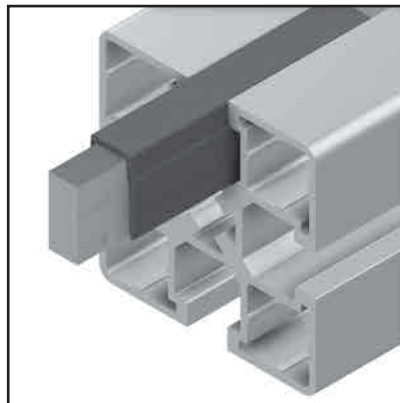
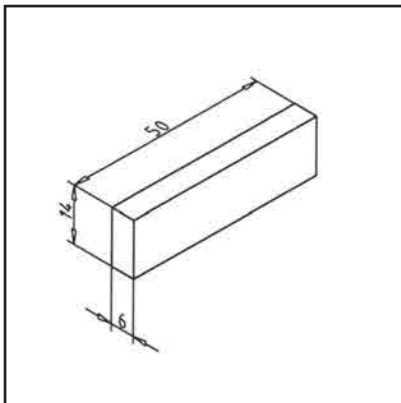
**TECHN. DATA / ITEMS SUPPLIED**

- NeFeB N35, nickel-plated
- Without fastening kit
- Attention: Electric- and memory devices can be faulted by the magnet
- Power density,  $BH_{mx} = 263 \text{ kJ/m}^3$
- Remanence,  $B_r = 1170 \text{ mT}$
- coercive field strength  $H_{cj} = 955 \text{ kA/m}$
- max. service temperature  $+80 \text{ }^\circ\text{C}$
- Weight = 0.030 kg/piece

**APPLICATIONS**

- Adhesive magnet for tools
- Use under conveyor belts as tracking, for magnetizable conveying products or at higher conveying speeds
- Fitting for all profiles of profile series 45

**ASSEMBLY**

- Snap or slip the cover profile into profile groove
- Insert magnet into t-slot
- For fastening: (mighty recommended) Use end cap AL, set screw with square nut or t-slot bar



**MAGNET 6 X 9 X 50 MM**

Part no.

21.0040/0

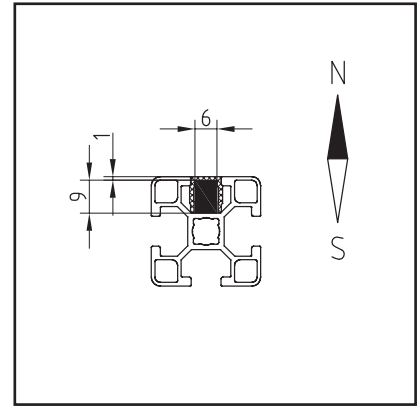
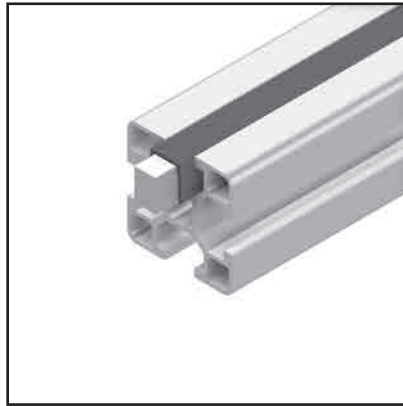
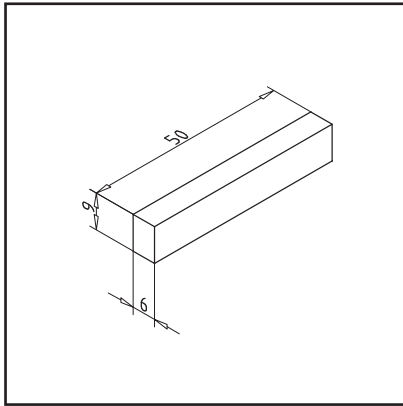
**TECHN. DATA / ITEMS SUPPLIED**

- NeFeB N45, nickel-plated
- Without fastening kit
- Attention: Electric- and memory devices can be faulted by the magnet
- Power density,  $BH_{mx} = 342 \text{ kJ/m}^3$
- Remanence,  $B_r = 1320 \text{ mT}$
- coercive field strength  $H_{cj} = 955 \text{ kA/m}$
- max. service temperature  $+80 \text{ }^\circ\text{C}$
- Weight = 0.023 kg/piece

**APPLICATIONS**

- Adhesive magnet for tools
- Use under conveyor belts as tracking, for magnetizable conveying products or at higher conveying speeds
- Fitting for all profiles of profile series 30

**ASSEMBLY**

- Snap or slip the cover profile into profile groove
- Insert magnet into t-slot
- For fastening: (might recommended) Use end cap AL, set screw with square nut or t-slot bar

STORAGE BOXES

Type 1

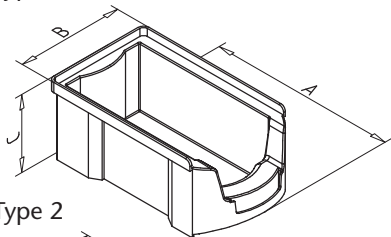

Type 2

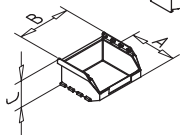

TECHNICAL DATA

- Optimal overview and convenient access to the content
- Large handles on the front and back for easy handling
- Dimensionally stable
- Resistant to most acids and oils
- temperature resistance (-20° to +80°C)

APPLICATION

- Provision of small parts, screws, nuts etc. at assembly workstations
- Ergonomic workplace systems

ASSEMBLY

- Mount storage boxes with storage box holder, 1-fold part no. 32.0509/0 or with multiple storage box holder part no. 32.0532/0 on tool holder plate or carrier

Type	Part no.	Measure A	Measure B	Dimension C	Color
1	32.0540/0	360	210	147	blue
	32.0540/5	350	200	145	black ESD
1	32.0541/0	229	148	122	blue
	32.0541/5	235	145	125	black ESD
1	32.0542/0	167	104	76	blue
	32.0542/5	175	100	75	black ESD
2	32.0543/0	85	100	50	blue
	32.0543/5	95	100	50	black ESD

**STORAGE BOX SHELF**

Part no.

32.0514/0

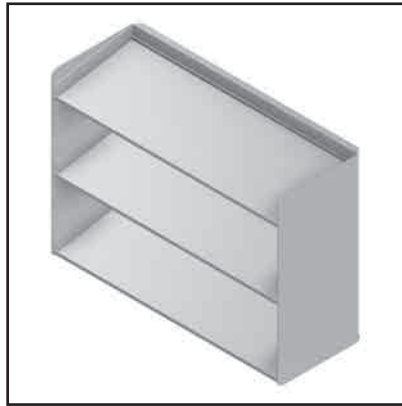
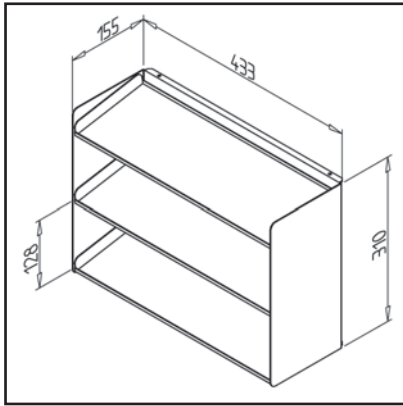
**TECHN. DATA / ITEMS SUPPLIED**

- Steel, powder-coated, grey
- 3 levels
- Weight = 3.800 kg/piece

**APPLICATIONS**

- For semi open front containers and small hardware
- For max. 12 semi open front containers, L= 165 mm, W= 105 mm, H= 75 mm

**ASSEMBLY**

- Fasten to the portal structure
- Freestanding or in combination with box holder **part no. 32.0516/0** swiveling
- Optional: in ESD-design **part no. 32.0514/6**

**STORAGE BOX HOLDER**

Part no.

32.0516/0

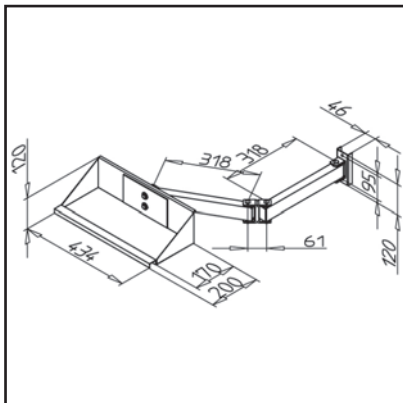
**TECHN. DATA / ITEMS SUPPLIED**

- Steel, powder-coated, grey
- Fastening material
- Front handle bar
- With double articulated arm 700 mm long
- Load capacity 150 N
- Weight = 4.300 kg/piece

**APPLICATIONS**

- As storage area for semi open front containers and semi open front container racks

**ASSEMBLY**

- Installation on the vertical strut of the portal structure
- Optional: in ESD-design **part no. 32.0516/6**

## KANTAINER

The newly developed KanTainer offers the ideal prerequisite for implementing the principles of lean production in your company using Kanban control.



In combination with the mounting solutions and the ergonomic designed working places of MiniTec, a complete, safe and economic all-round-package for your manual production is ensured. The Kantainer is designed for maximum space utilization in the warehouse with optimal material provision at the workplace. The Kantainer offers all the prerequisites to make

storage, order picking and assembly easier and safer. Thanks to the compatible system components of our extensive MiniTec modular system, we are able to optimally solve virtually every task in manual assembly.

## FUNCTIONS

- For continuous kanban system: no transfer - no error-prone refilling
- Total storage rack use by retractable grip plate
- Ergonomically optimized grip plate eases the removal
- Transparent cover against soiling and mixing of parts
- Cover as protection against unintentional opening or loss of parts
- Simple content control
- Transparent dosing disc: easy recognition of residual quantities
- Dosing disc prevents uncontrolled trickling out of small parts
- Secure stacking through locating pins and eyelets
- Double-sided labelling
- Retaining device at the back of the container
- Bottom guide rails for longitudinal and transverse transport

## TECHNICAL DATA

- Dimensions: 175x126x88 [mm]
- Superimposed load 50 kg
- Content load: 5 kg
- Temperature resistance: -20°C to +90°C
- Material: polypropylene, polystyrene
- Color:
  - Basalt grey (RAL 7012) [Part no.: 32.0870/0]
  - Orange (RAL 2004) [Part no.: 32.0870/1]
  - Black ESD conductive [Part no.: 32.0870/5]

The ESD-conductive Kantainer is the optimal and logical addition to our ESD workstation systems.



**KANTAINER-SWIVEL CANTILEVER, 3-FOLD**

Part no.

32.0877/0

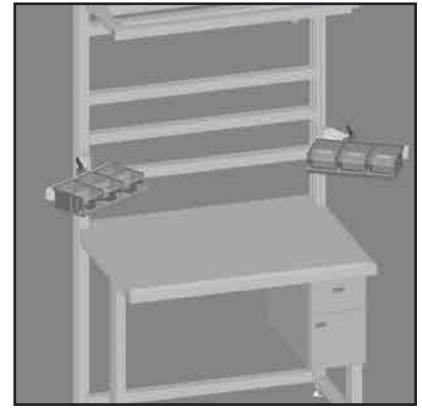
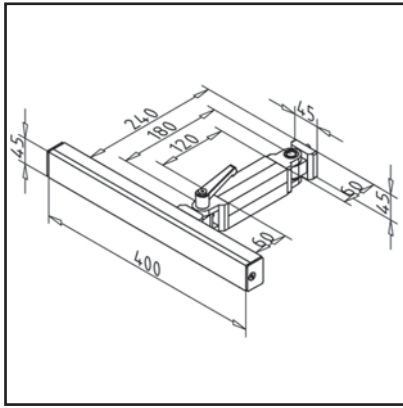
**TECHN. DATA / ITEMS SUPPLIED**

- Profile 45 x 32 F and 45 x 45 F
- heavy duty joint and swivel joint with clamping lever with supplied hardware
- Load capacity: max.= 100 N
- Weight = 1.916 kg/piece

**APPLICATIONS**

- Accepting 3 KanTainers

**ASSEMBLY**

- Mount the heavy load hinge on the table

**KANTAINER - SHELF (STRAIGHT)**

Part no.

32.0876/0

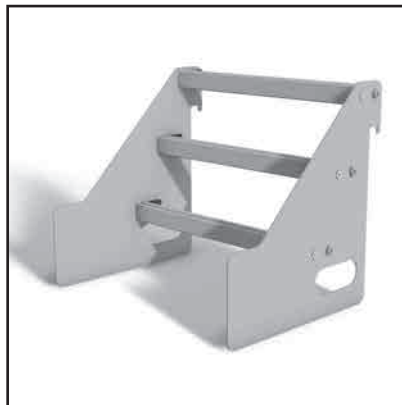
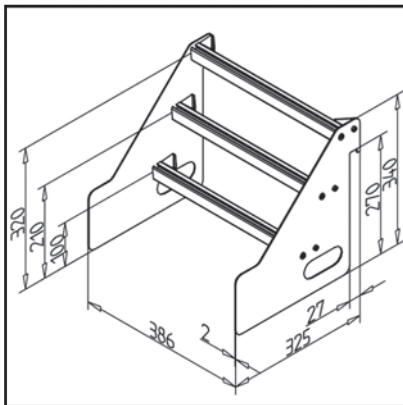
**TECHN. DATA / ITEMS SUPPLIED**

- Side panels steel, powder coated, grey
- Intermediate struts of profile 23 x 30
- Delivery as construction set
- Fastening kit
- Weight = 3.400 kg/piece

**APPLICATIONS**

- Accepting 9 KanTainers
- Adjustable inclination
- With the hooks on the back, the shelf can also be hung in our profile grooves

**ASSEMBLY**

- Screw profiles to side panels with supplied mounting angles and mounting hardware

## MONITOR SUPPORT LX AND LX HD







## APPLICATION

The LX and LX HD monitor supports are suitable for a wide range of applications: suitable for large monitors, medium-sized televisions and all-in-one computers weighing up to 13.6 kg. The LX offers a large range of motion and is suitable for both sedentary and standing users, allows vertical adjustment of up to 51 cm and lateral adjustment of 157 cm.

## ADVANTAGES

- More freedom and flexibility through maximum ergonomic comfort
- Maximum comfort when positioning the monitor
- Integrated cable management
- Up to 51 cm stepless height adjustment, meets the ergonomic principles of more than 90% of all users
- Arm can be pulled back over the base plate and fold up; suitable for storage in shelves or cupboards in confined spaces
- Outstanding viewing comfort prevents health risks in the neck and back
- LCD range up to 88 cm. Simply slide the screen to the side if you are not using it

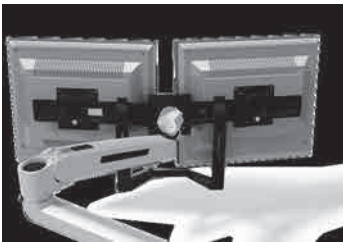
		
	LX HD arm for wall mounting	LX arm for wall mounting
Part No.	32.0623/0	32.0622/0
Scope of delivery	LX HD sit-stand-arm, extension, wall mounting base, VESA brackets incl. mounting material	LX LCD-arm, bracket arms, wall bracket base. Direct mounting on solid vertical surfaces incl. mounting material
Maximum screen size	46"	24"
Screen size may vary. Details refer to the screen diagonal.		
Load-bearing capacity	6,3–13,6 kg	3.2-9.1 kg monitor depth can be greater than 5 cm reduce capacity
Height adjustment	51 cm	33 cm
Tilt function	80° 75° / 5°	75° 70° / 5°
Swivel function	360°	360°
Rotation	90° Rotation with portrait / landscape mode	90° Rotation with portrait / landscape mode
VESA	75x75mm/100x100mm/200x100mm/200x200mm	75x75mm/100x100mm
Depth	Foldable to 12 cm	Foldable to 13.4 cm
Reach up	84 cm	64 cm
Transport weight	9,1 kg	3,2 kg
Transport dimensions	64 x 38 x 19 cm	53 x 29 x 19 cm
<b>ACCESSORIES</b>		
32.0612/0	Keyboard tray	
	Keyboard shelf made of sheet steel, powder-coated matt black for mounting on monitor carrier LX / LX HD. Rear cable entry for mouse and keyboard. The distance to the monitor is adjustable. For fastening the existing VESA holes are used. When used, the arm is additionally loaded with 2.4kg.	
32.0624/0	Monitor handle Kit	
	Can be attached to many mounts using a bolt circle of 50 x 50mm, 100 x 100mm or 200 x 100mm. Robust design ensures long service life. Suitable for displays up to a size of 32 inches. When used, the arm is additionally loaded with 1.3 kg.	
39.0118/0	Dual monitor support for LX HD	
	<p>Recording for 2 monitors and a handle</p> <ul style="list-style-type: none"> <li>- Integrated cable management</li> <li>- Load capacity: 6.3 - 10.5 kg</li> <li>- Height adjustment: 510 mm</li> <li>- Extension: up to 840 mm</li> <li>- Tilt function: 80°</li> <li>- Rotation: 90°</li> <li>- VESA mounting standard: 75 x 75 mm 100 x 100 mm</li> <li>- Maximum display size: 46 "</li> </ul> <p>- When used the arm is additionally loaded with 2.7 kg.</p>	



## STORAGE CONSOLE WITH CLAMPING LEVER

Part no.

32.0501/0

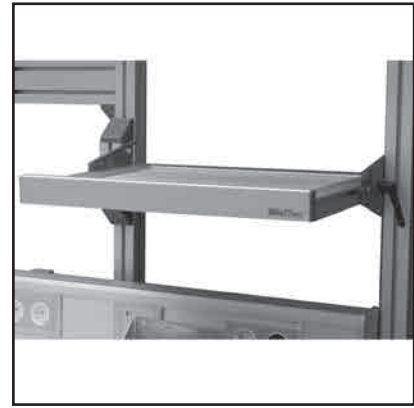
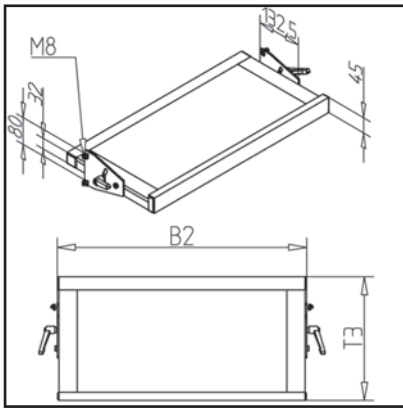

### TECHN. DATA / ITEMS SUPPLIED

- Sturdy frame made of aluminum profiles anodized E6 / EV1
- Shelf for cabinet, chipboard, light grey
- Front edge 13 mm raised edges
- ESD on request
- **Please state table width B2 and depth T3**
- Load capacity: 400 N

### APPLICATIONS

- Continuously inclinable from  $-30^{\circ}$  to  $+30^{\circ}$
- Rack is adjustable

### ASSEMBLY

- Fastening with 2 swivel plates to the portal structure
- without clamp lever **part no. 32.0501/1**

## STORAGE SHELF / MONITOR SUPPORT ROTATING CRT

Part no.

32.0512/0

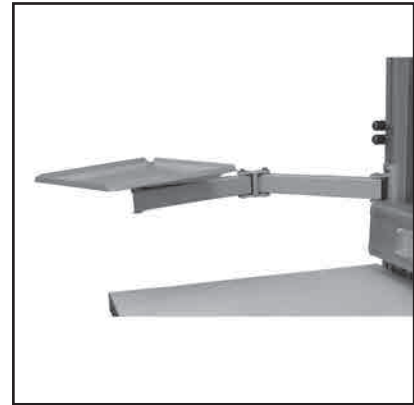
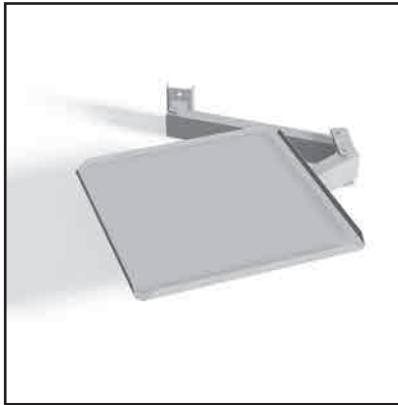
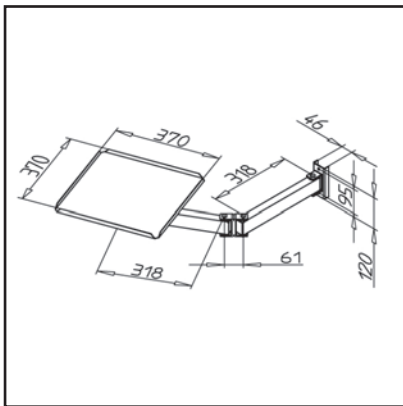

### TECHN. DATA / ITEMS SUPPLIED

- Steel, powder coated, light grey
- Double joint design, length 430 mm
- Monitor and keyboard panel rotatable
- Monitor panel: 370 x 370 mm
- Load capacity 150 N
- Weight = 4.200 kg/piece

### APPLICATIONS

- Provision of IT data, guidelines, Internet connection

### ASSEMBLY

- Screw onto the portal structure
- Optional as ESD version **Part no. 32.0512/6**

## MONITOR SUPPORT WITH KEYBOARD TRAY TFT

Part no.

32.0517/0

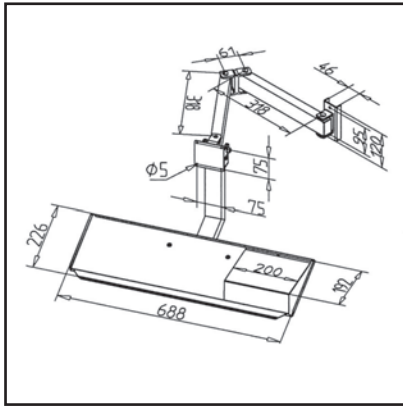

### TECHN. DATA / ITEMS SUPPLIED

- Steel, powder-coated, grey
- Monitor and keyboard carrier with mouse rack
- With double-articulated swing boom
- Delivery as construction set
- ESD on request
- Load capacity 150 N
- Weight = 7.400 kg/piece

### APPLICATIONS

- The mouse rack is shiftable and therefore suitable for right and left-handers

### OTHER VERSIONS

- Support with keyboard shelf with VESA connection adapter 75 mm **part no. 32.0517/0**
- Support with keyboard shelf with VESA connection adapter 100 mm **part no. 32.0517/1**
- Support without keyboard shelf with VESA connection adapter 75 mm **part no. 32.0525/0**
- Support without keyboard shelf with VESA connection adapter 100 mm **part no. 32.0526/0**

## KEYBOARD STORAGE

Part no.

32.0518/0

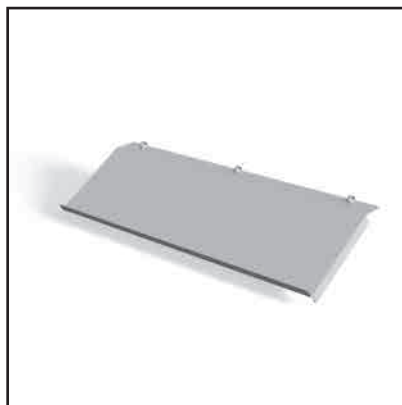
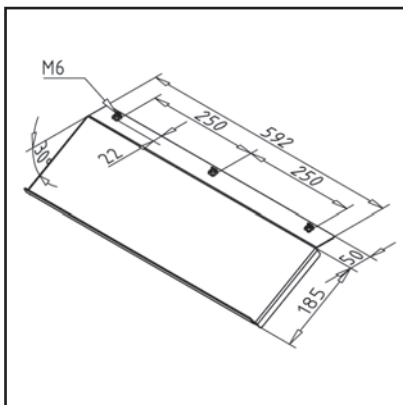

### TECHN. DATA / ITEMS SUPPLIED

- Stainless steel
- Stainless steel 2mm, grounded
- Rustproof
- For standard keyboards
- With slide nuts M6Z, ESD-compatible
- Fastening material
- Load capacity 150 N
- Weight = 2.477 kg/piece

### APPLICATIONS

- For setting the keyboard on the workplace

### ASSEMBLY

- Fasten to profile groove with supplied hardware

**MONITOR CARRIER V 100**

Part no.

32.0053/0

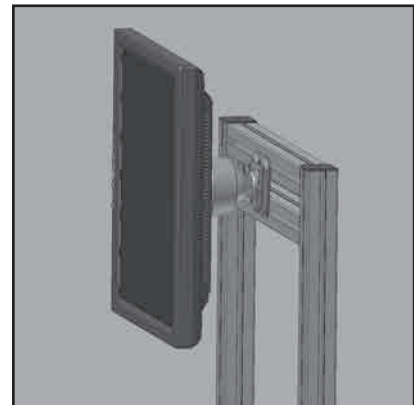
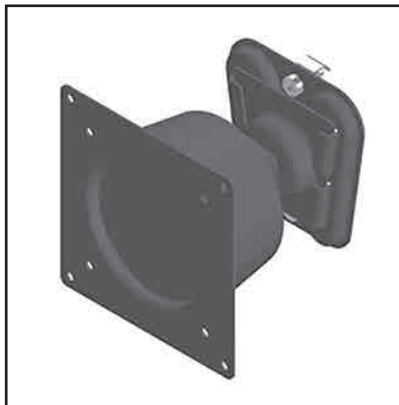
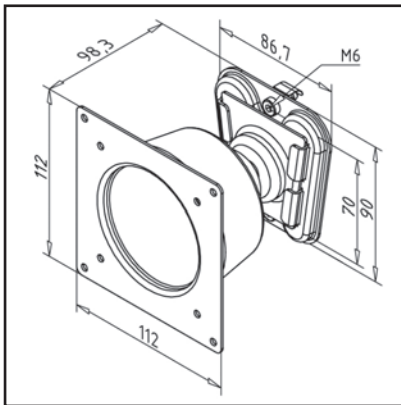
**TECHN. DATA / ITEMS SUPPLIED**

- Steel, powder coated black
- Fastening kit
- Load capacity 150 N
- Weight = 0.568 kg/piece

**APPLICATIONS**

- Swiveling with ball joint
- Monitor can be rotated through 180°
- For VESA standard 75 x 75 mm / 100 x 100 mm

**ASSEMBLY**

- Fasten to profile groove with supplied hardware.

## DOCUMENT BAR

Part no.

32.0610/0

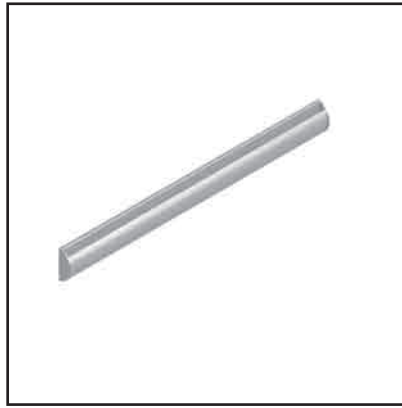
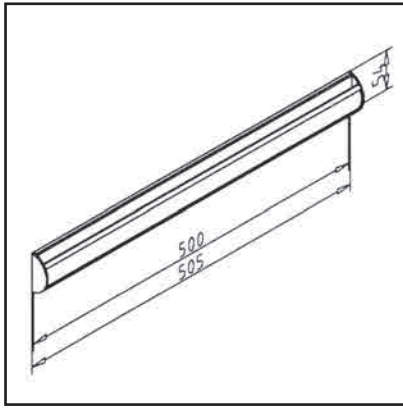

### TECHN. DATA / ITEMS SUPPLIED

- Aluminium anodized
- With clamping balls made of special glass
- Length: 505 mm
- Other dimensions upon request
- Weight = 0.300 kg/piece

### APPLICATIONS

- Safe attachment of large drawings, instructions, plans
- Simply slip-in papers from below
- Attach to portal construction by screwing or gluing with double-faced adhesive tape

### ASSEMBLY

- Use the screws of fastening kit or fasten with adhesive tape on the back

## DOCUMENT SUPPORT

Part no.

32.0605/0

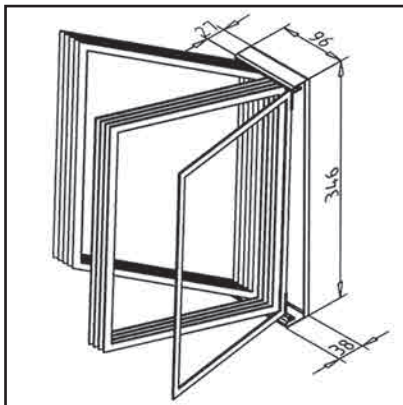

### TECHN. DATA / ITEMS SUPPLIED

- Steel bracket, powder coated light grey
- 10 DIN A4 boards, transparent
- Border per 5 in blue and red
- 5 Slip-on tabs
- Weight = 1.240 kg/piece

### APPLICATIONS

- Provision of job instructions, maintenance notes
- Control boards, general information
- Screw tight onto portal construction

### ASSEMBLY

- Fastening with 2 hex socket cap screws M 06 x 16, 2 square nut M6 into profile groove
- ESD-design **part no. 32.0605/6**

## BALANCER

Part no.

29.0111/0

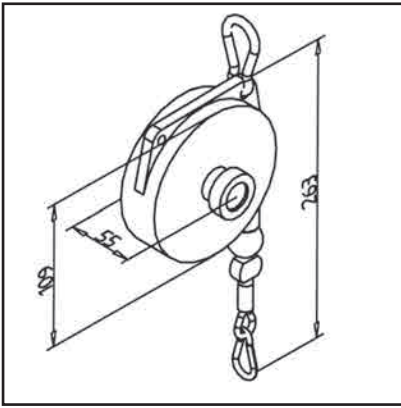

### TECHN. DATA / ITEMS SUPPLIED

- For tool weights 2-3 kg
- For higher weights upon request
- Weight = 0.753 kg/piece

### APPLICATIONS

- Grab-supportive tool suspensions

### ASSEMBLY

- With snap hook from scope of delivery in tool glider **part no. 22.1213/0**

## TOOL SLIDER H

Part no.

22.1213/0

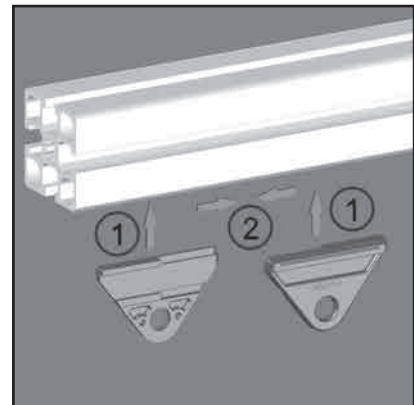
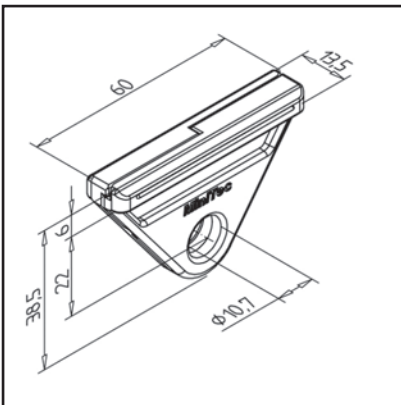

### TECHN. DATA / ITEMS SUPPLIED

- ABS, Injection Mould, grey
- load capacity up to 600 N
- Weight = 0.010 kg/piece

### APPLICATIONS

- Grab-supportive tool suspensions
- Suitable for all 45er profiles

### ASSEMBLY

- insert both halves in profile groove and press together
- Optional: spring clip 60x6 **part no. 21.1699/0**

**TOOL SLIDE**

Part no.

32.0545/0

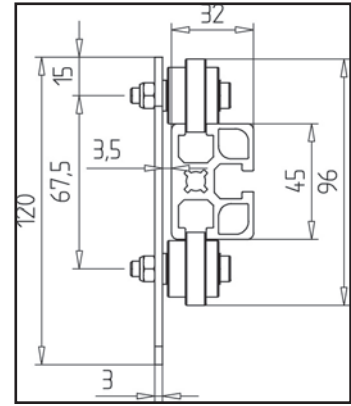
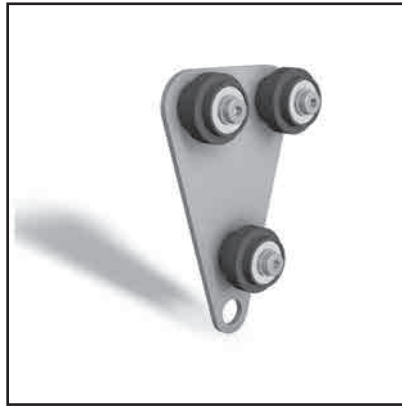
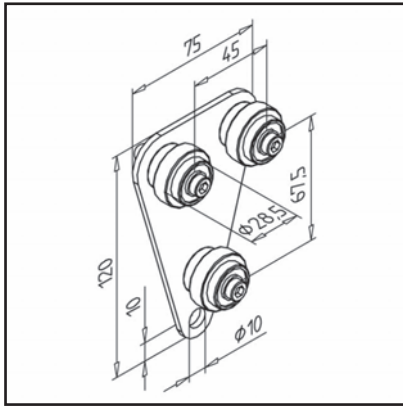
**TECHN. DATA / ITEMS SUPPLIED**

- Stainless steel
- Caster wheel ABS grey
- Load capacity F: 400 N
- Weight = 0.263 kg/piece

**APPLICATIONS**

- For guiding of tools on working tables

**ASSEMBLY**

- Slide into profile end
- Possibly before disassembly of the lower roller
- Can be used in connection with balancer, **part no. 29.0111/0**

**C-SECTION RAIL 30**

Part no.

32.0220/0

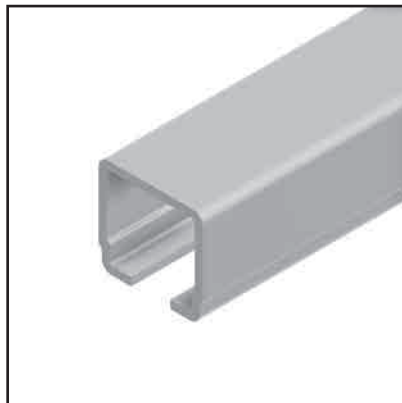
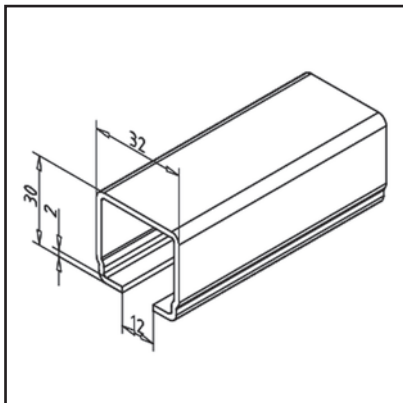
**TECHN. DATA / ITEMS SUPPLIED**

- Steel, galvanized
- $I_x = 2.42 \text{ cm}^4$
- $I_y = 1.45 \text{ cm}^4$
- ESD-compatible
- Weight = 1.560 kg/m
- Bar length = 6 m

**APPLICATIONS**

- Reception and guide of cable trolleys
- Reception and guide of tool trolleys to provide heavy tools

**ASSEMBLY**

- Attach to portal structure with rail holder **part no. 32.0222/0**

## RAIL HOLDER

Part no.

32.0222/0

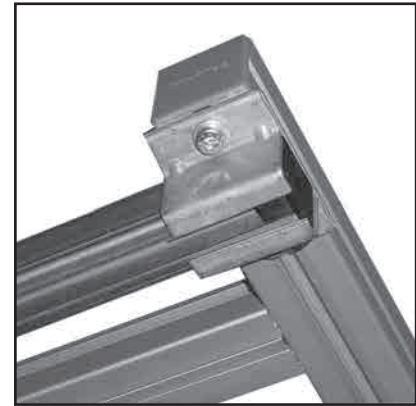
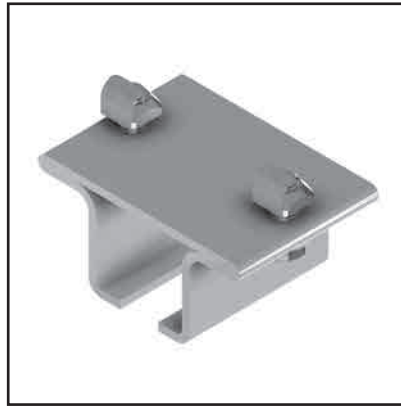
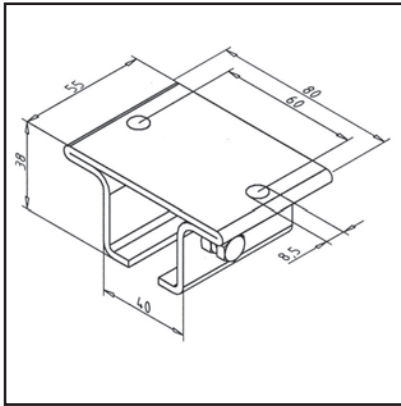

### TECHN. DATA / ITEMS SUPPLIED

- Steel, galvanized
- Square nut Z, ESD capable
- Weight = 0.250 kg/piece

### APPLICATIONS

- Fastening the C-section rail onto the portal structure
- Fixation for C-rail 30 **part no. 32.0220/0**

### ASSEMBLY

- Fasten to the portal construction with supplied hardware

## CLOSURE CAP FOR C-RAIL

Part no.

32.0223/0

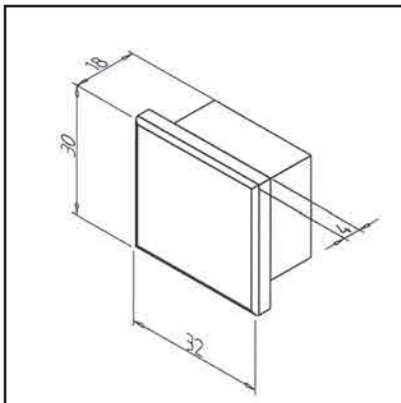

### TECHN. DATA / ITEMS SUPPLIED

- Plastic, black
- Weight = 0.006 kg/piece

### APPLICATIONS

- Closing of both rail ends

### ASSEMBLY

- Press onto C-profile rail



**END STOP C-RAIL**

Part no.

32.0226/0

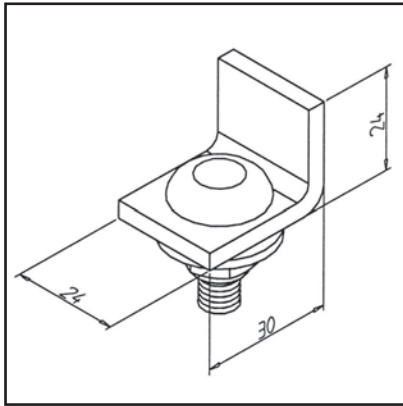
**TECHN. DATA / ITEMS SUPPLIED**

- Steel, galvanized
- Fastening material
- ESD-compatible
- Weight = 0.060 kg/piece

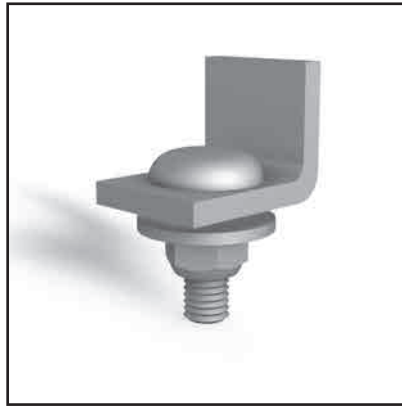
**APPLICATIONS**

- Fasten the cable trolley **part no. 32.0225/0** and tool trolley **part no. 32.0224/0** at the end of the rail

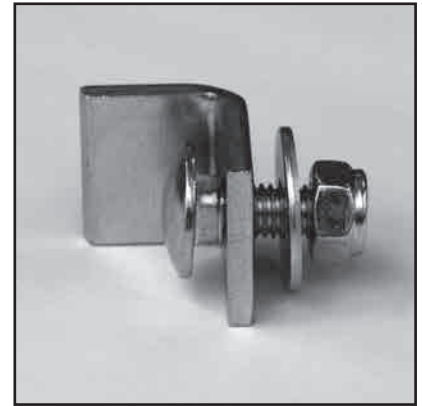
**ASSEMBLY**

- Screw into end of C-section rail

**TOOL TROLLEY**

Part no.

32.0224/0

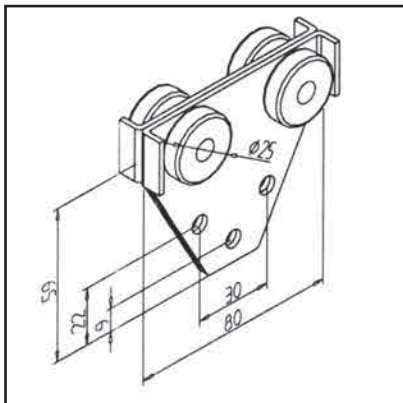
**TECHN. DATA / ITEMS SUPPLIED**

- Steel, galvanized
- 4 rollers, zinc plated, ball bearings sealed on both sides
- ESD-compatible
- Load capacity: 16 kg
- Weight = 0.210 kg/piece

**APPLICATIONS**

- Suspension of tools in the work area

**ASSEMBLY**

- Push into C-section rail, secure ends with limit stop

## CABLE TROLLEYS FOR ROUND CABLES

Part no. 32.0225/0

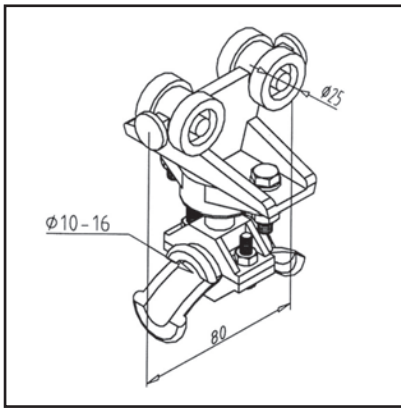

### TECHN. DATA / ITEMS SUPPLIED

- Plastic, yellow
- Supporting body: plastic, yellow
- 4 plastic rollers
- Load capacity: 8 kg
- Weight = 0.135 kg/piece

### APPLICATIONS

- Smooth running guidance of lines
- Suspension of hoses and pipes

### ASSEMBLY

- Push into C-section rail, secure ends with limit stop

## SWIVEL CANTILEVER C-RAIL 30

Part no. 32.0230/0

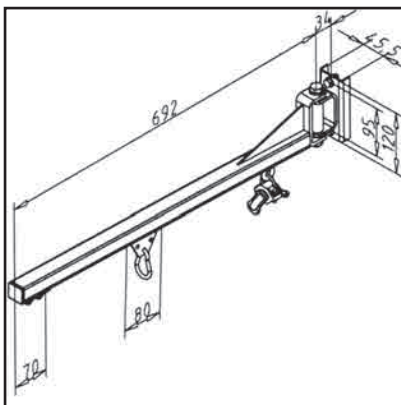

### TECHN. DATA / ITEMS SUPPLIED

- Steel, powder-coated, grey
- 180° swiveling
- Fastening material
- Length: 692 mm
- Load capacity: 200 N
- Weight = 2.310 kg/piece

### APPLICATIONS

- For compressed air and power tools

### ASSEMBLY

- Slight slope to the rear, so that unused tool slides automatically from work area
- Fasten to the portal construction with supplied hardware
- Optional: as ESD design **part no. 32.0230/6**

**SWIVEL ARM ECO**

Part no.

32.0201/0

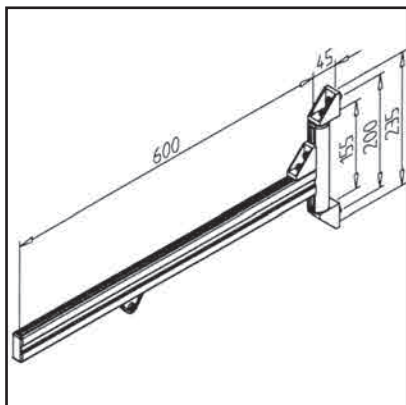
**TECHN. DATA / ITEMS SUPPLIED**

- Aluminium
- 200° swiveling
- Fastening material
- plain bearing
- Length: 600 mm
- Load capacity: max.= 100 N
- Weight = 1.100 kg/piece

**APPLICATIONS**

- For compressed air and power tools

**ASSEMBLY**

- Fixing to portal with angle
- Fasten to the portal construction with supplied hardware

**CONTAINER HOLDER 32-400**

Part no.

32.0306/0

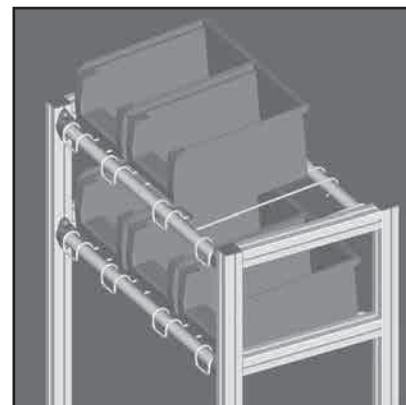
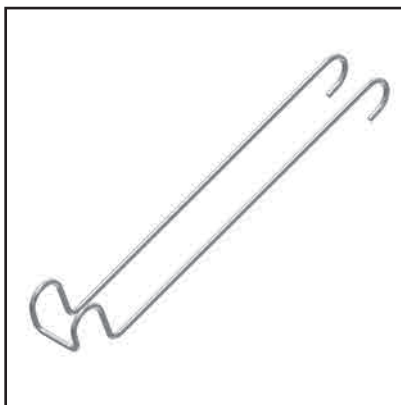
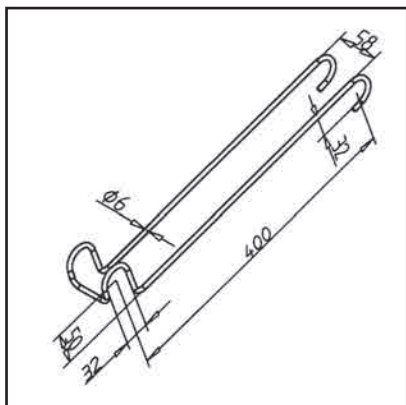
**TECHN. DATA / ITEMS SUPPLIED**

- Steel, galvanized
- Without fastening kit
- Weight = 0.268 kg/piece

**APPLICATIONS**

- as depositing rack for semi-open front containers and storage containers

**ASSEMBLY**

- simply hooked into handle profile 32 from both sides
- Recommended: If required, secure laterally against sliding of snap bolt 25 **part no. 21.1758/0**

## MOUNTING BLOCK

Part no.

32.0539/0

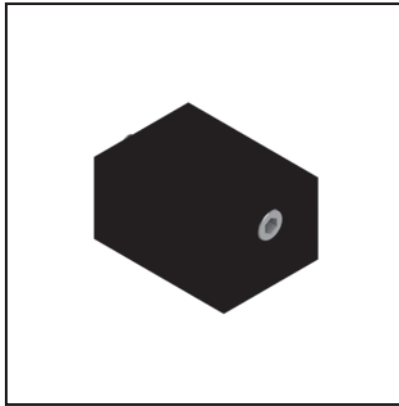
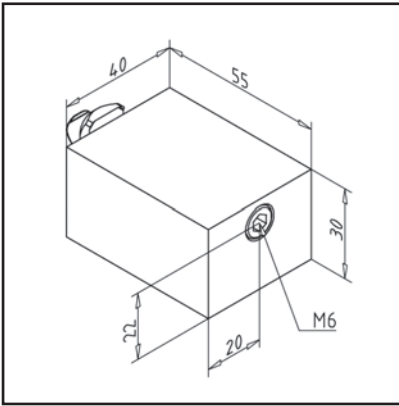

### TECHN. DATA / ITEMS SUPPLIED

- Plastic
- Color: black
- Fastening kit
- Square nut Z, ESD capable
- Weight = 0.078 kg/piece

### APPLICATION

- For self drilling of individual hole patterns
- To provide tools etc.

### ASSEMBLY

- Fasten into profile groove with fastening kit

## ATTACHMENT CLIP 16

Part no.

32.0538/0

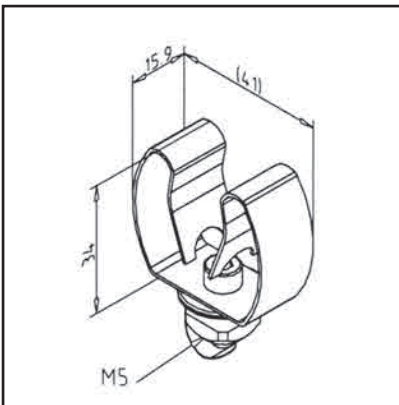

### TECHN. DATA / ITEMS SUPPLIED

- Steel
- Stainless steel 1.4319
- Attachment clip with fastening kit
- Square nut Z, ESD capable
- Weight = 0.028 kg/piece

### APPLICATIONS

- Holder for various tools with  $\varnothing$  16 - 25 mm

### ASSEMBLY

- Fasten into the profile groove with supplied hardware and tighten the fastening screw

**ATTACHMENT CLIP 8**

Part no.

32.0537/0

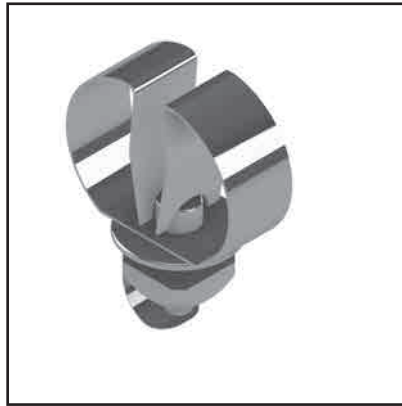
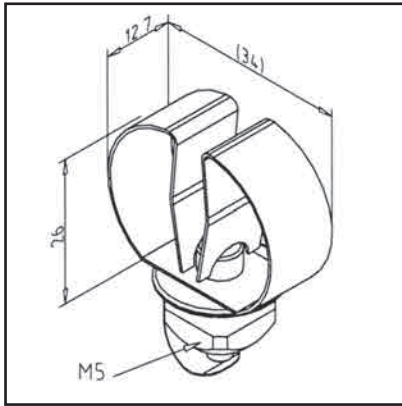
**TECHN. DATA / ITEMS SUPPLIED**

- Steel
- Stainless steel 1.4319
- Attachment clip with fastening kit
- Square nut Z, ESD capable
- Weight = 0.017 kg/piece

**APPLICATIONS**

- Holder for various tools with  $\varnothing$  8 - 12 mm

**ASSEMBLY**

- Fasten into the profile groove with supplied hardware and tighten the fastening screw

**ROUND TOOL HOLDER 38 - 120**

Part no.

32.0536/0

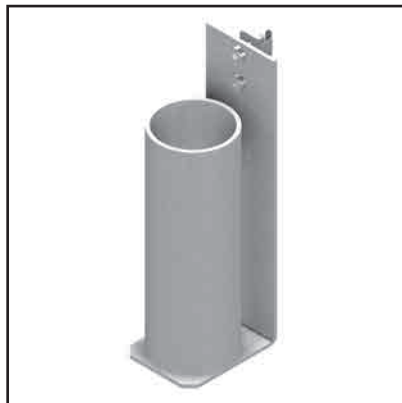
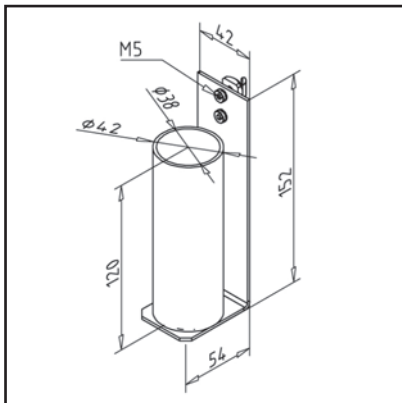
**TECHN. DATA / ITEMS SUPPLIED**

- Stainless steel
- Material V2A, polished
- Fastening kit
- Square nut Z, ESD capable
- Weight = 0.402 kg/piece

**APPLICATIONS**

- Tool holder for storage of tools, pins, etc.
- Adjustable angle

**ASSEMBLY**

- Attach with fastening kit from items supplied to profile strut

## ROUND TOOL HOLDER 38-70

Part no.

32.0535/0

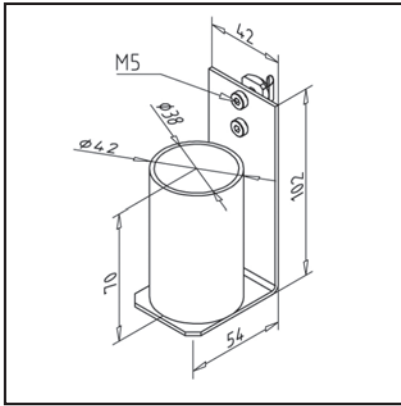

### TECHN. DATA / ITEMS SUPPLIED

- Stainless steel
- Material V2A, polished
- Fastening kit
- Square nut Z, ESD capable
- Weight = 0.263 kg/piece

### APPLICATIONS

- Tool holder for storage of tools (files, marking tools, sharpening stones, etc.)
- Adjustable angle

### ASSEMBLY

- Attach with fastening kit from items supplied to profile strut

## STEEL BRACKET 250

Part no.

32.0533/0

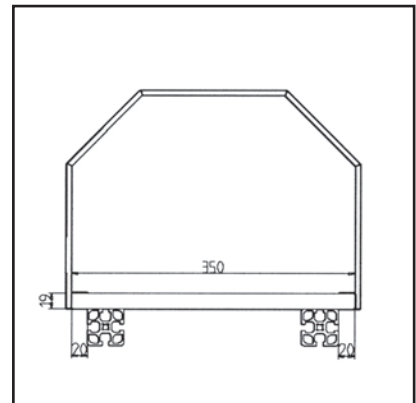
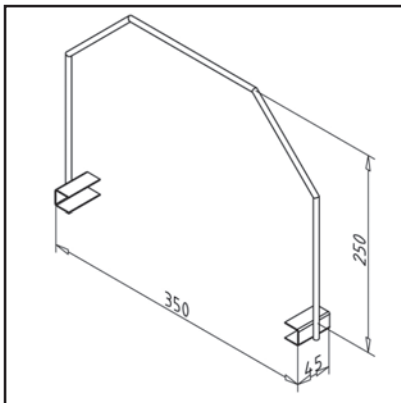

### TECHN. DATA / ITEMS SUPPLIED

- Steel, powder-coated, grey
- With welded-on clamps for setting on a 19 mm chipboard, for example
- Clamped using pretensioning and can be secured additionally with wood screws
- Weight = 0.214 kg/piece

### APPLICATIONS

- As separating web for cartons
- Magazine for flat parts

### ASSEMBLY

- Pull apart gently, stick on at the correct position and secure with suitable screw

**STEEL BRACKET 400**

Part no.

32.0534/0

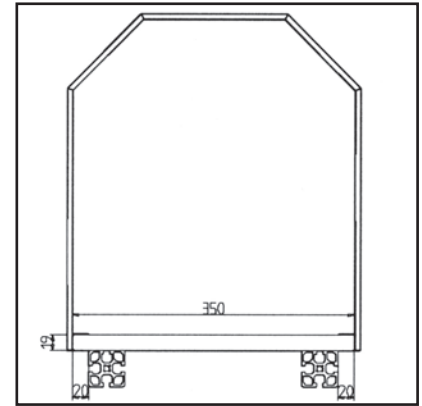
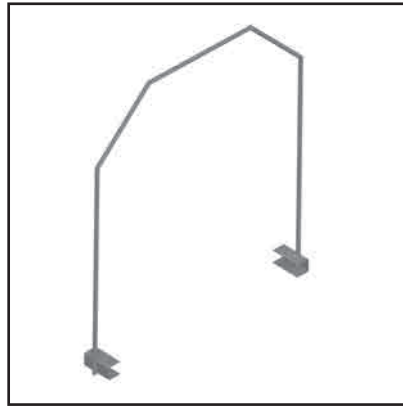
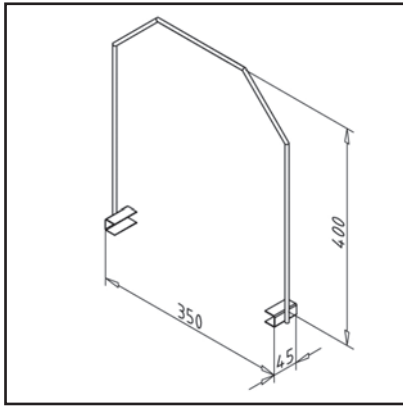
**TECHN. DATA / ITEMS SUPPLIED**

- Steel, powder-coated, grey
- With welded-on clamps for setting on a 19 mm chipboard, for example
- Clamped using pretensioning and can be secured additionally with wood screws
- Weight = 0.278 kg/piece

**APPLICATIONS**

- As separating web for cartons
- Magazine for flat parts

**ASSEMBLY**

- Pull apart gently, stick on at the correct position and secure with suitable screw

**DRAWING HOLDER**

Part no.

32.0608/0

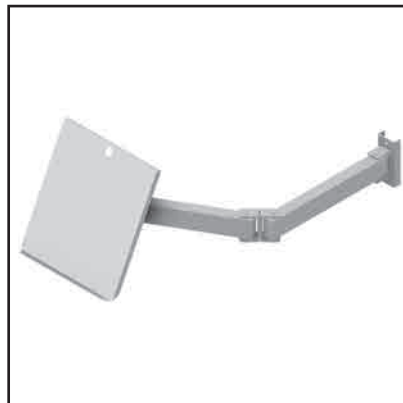
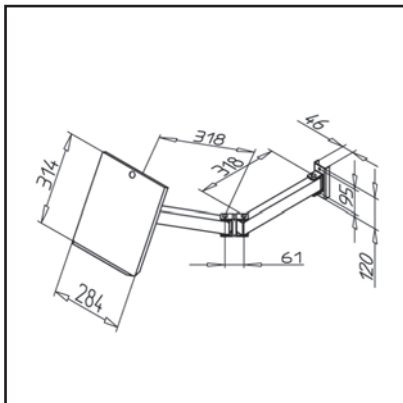
**TECHN. DATA / ITEMS SUPPLIED**

- Steel light grey, powder coated
- With double-articulated swing boom
- For DIN A4 format
- Load capacity 150 N
- Delivery as construction set
- ESD on request
- Weight = 4.000 kg/piece

**APPLICATIONS**

- For documents, control charts and drawings

**ASSEMBLY**

- Fasten to the portal structure



## DOCUMENT CLIP

Part no.

32.0609/0

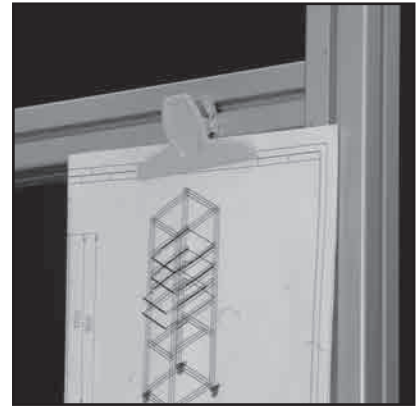
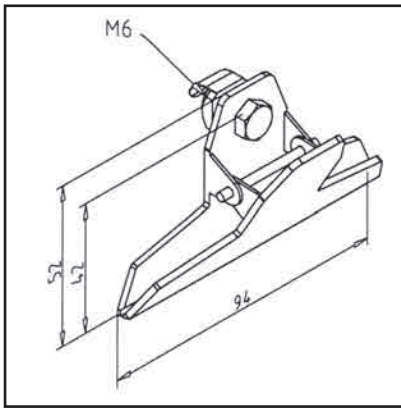

## TECHN. DATA / ITEMS SUPPLIED

- Steel light grey, powder coated
- With fastening bore  $\varnothing$  6mm
- Width x height 94 x 52 mm
- Weight = 0.048 kg/piece

## APPLICATIONS

- To fastening work instructions, work plans or the like to workbenches or other profile constructions

## ASSEMBLY

- Insert square nut M6 into profile groove and fasten with the screw

## QUICK LABEL 27 X 75

Part no.

32.0601/0

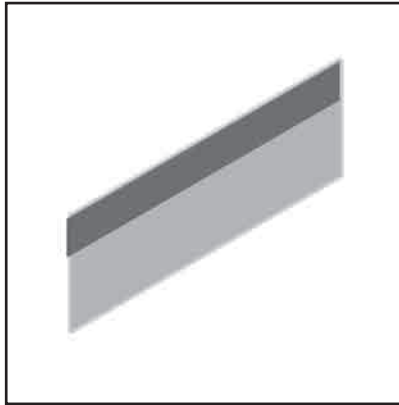
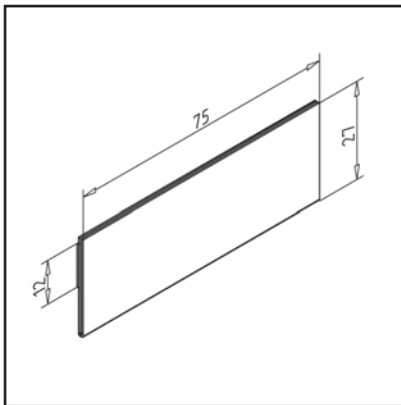

## TECHN. DATA / ITEMS SUPPLIED

- Front, transparent
- Back, self-adhesive
- Open at the sides and on top
- Weight = 0.003 kg/piece

## APPLICATIONS

- Storage compartment identification
- Error-free scanning of barcodes
- For profile width 32

## ASSEMBLY

- Attach with self-adhesive back
- Push in carton insert
- Cardboard insert not included in delivery scope, bows 20 pieces **part no. 32.0601/1** please order separately

**QUICK LABEL 38 X 100**

Part no.

32.0602/0

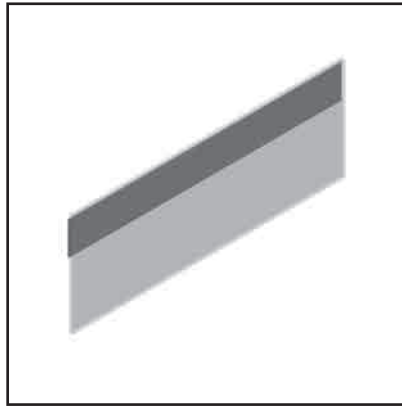
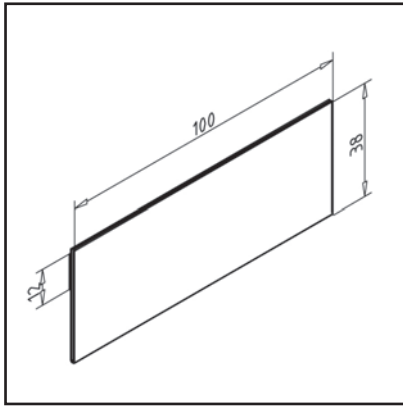
**TECHN. DATA / ITEMS SUPPLIED**

- Front, transparent
- Back, self-adhesive
- Open at the sides and on top
- Weight = 0.007 kg/piece

**APPLICATIONS**

- Storage compartment identification
- Error-free scanning of barcodes
- For profile width 45

**ASSEMBLY**

- Attach with self-adhesive back
- Push in carton insert
- Cardboard insert not included in delivery scope, bows 14 pieces **part no. 32.0602/1** please order separately

**SEMI-OPEN COMPARTMENT BASE ELEMENT**

Part no.

32.0615/0

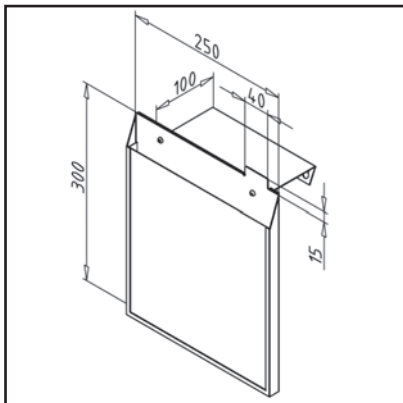
**TECHN. DATA / ITEMS SUPPLIED**

- Steel light grey, powder coated
- With fastening bores  $\varnothing 9$ , spacing 160 mm
- Optical edge 45 mm for optimum overview
- Filling capacity = 15 mm, sufficient for approx. 120 sheets of paper
- With grey closing plate
- clear semi-open compartment (front plate)
- Weight = 0.634 kg/piece

**APPLICATIONS**

- For size DIN A4 documents

**ASSEMBLY**

- Fasten to the portal structure
- Any time expandable with **part no. 32.0616/0**
- Extract the front panel during extension and attach it to the last extension element again

## SEMI-OPEN COMPARTMENT EXTENSION ELEMENT

Part no. 32.0616/0

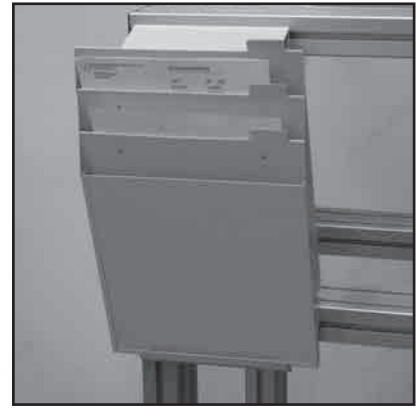
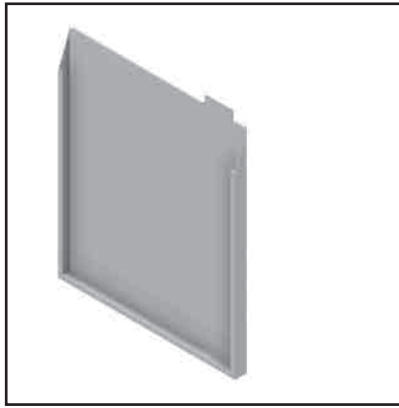
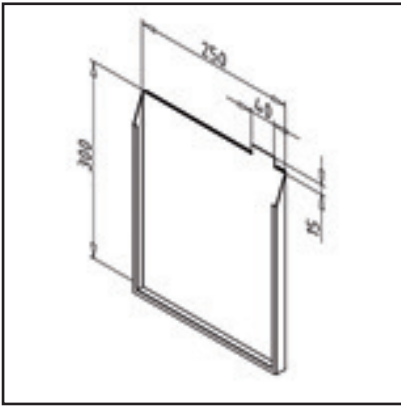

### TECHN. DATA / ITEMS SUPPLIED

- Steel, powder coated, light grey
- Filling capacity = 15 mm, sufficient for approx. 120 sheets of paper
- Weight = 0.392 kg/piece

### APPLICATIONS

- For size DIN A4 documents

### ASSEMBLY

- Place base element on compartment **part no. 32.0615/0**

## SEMI-OPEN COMPARTMENT, SINGLE

Part no. 32.0617/0

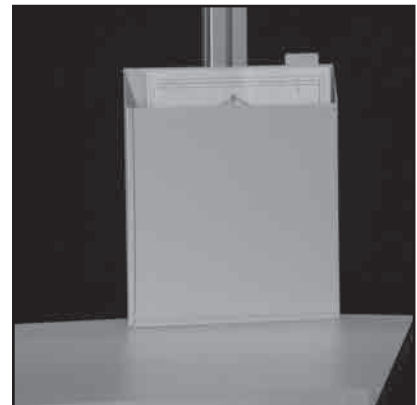
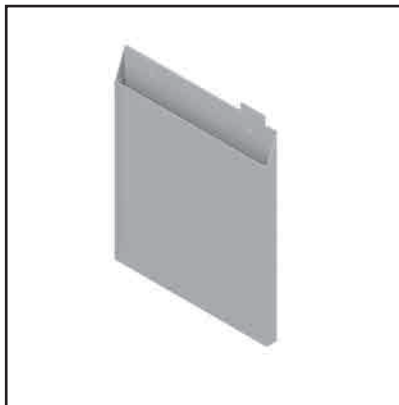
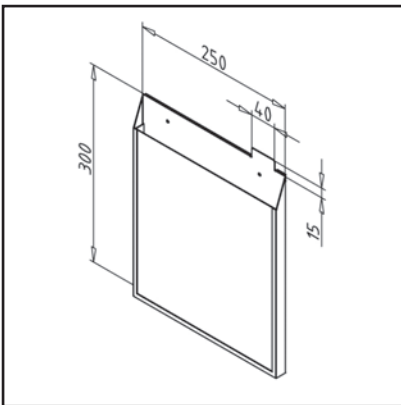

### TECHN. DATA / ITEMS SUPPLIED

- Steel, powder coated, light grey
- With fastening bores  $\varnothing$  4 mm, spacing approx. 16 mm
- With grey closing plate
- Weight = 0.500 kg/piece

### APPLICATIONS

- For size DIN A4 documents
- Optional: compartment single element DIN A4 portrait format with transparent locking plate **part no. 32.0619/0**

### ASSEMBLY

- Attach to the portal structure or use as an extension element for the base element

**ADDITIONAL ANGLE FOR VIEWING COMPARTMENT**

Part no.

32.0618/0

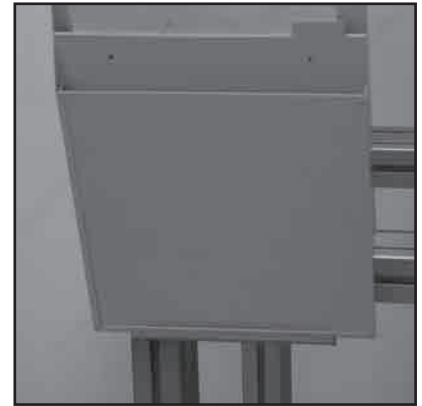
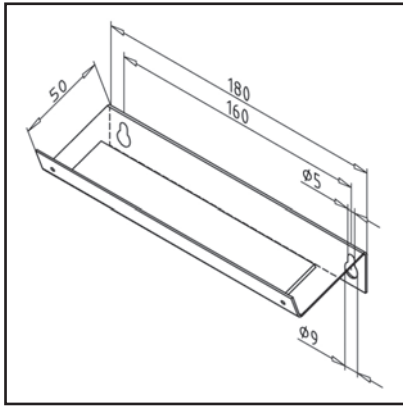
**TECHN. DATA / ITEMS SUPPLIED**

- Steel light grey, powder coated
- With magnet strips
- Weight = 0.123 kg/piece

**APPLICATIONS**

- For additional stabilisation on the bottom edge of the semi-open compartments

**ASSEMBLY**

- Fasten to the portal structure

**CUP HOLDER**

Part no.

32.0547/0

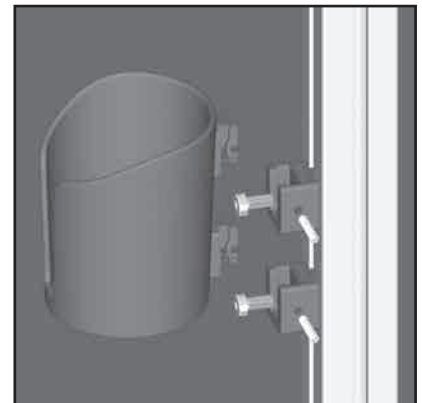
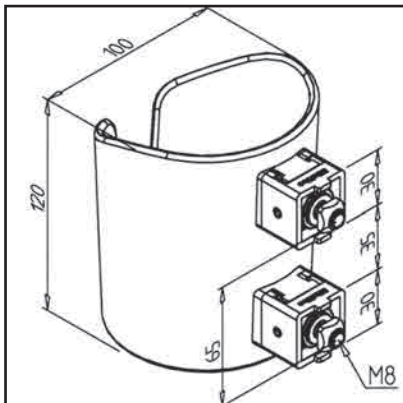
**TECHN. DATA / ITEMS SUPPLIED**

- PA, grey
- Cup with MiniTec company logo
- Fastening kit
- Weight = 0.388 kg/piece

**APPLICATIONS**

- Cup or bottle holder for workplace systems
- With cut-out for cup handle

**ASSEMBLY**

- Fasten rectangular connectors to post profile with supplied hardware at a distance of 35 mm
- Insert cup holder in t-slot
- For adjustment use set screw M5

**BOTTLES/DRINK CARTON HOLDER**

Part no.

32.0507/0

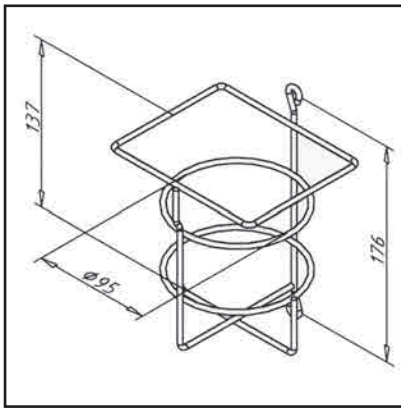
**TECHN. DATA / ITEMS SUPPLIED**

- Steel wire, coated light grey
- Inside Ø 95 mm
- 2 screws M6 x 16
- 2 square nuts M6 with spring plate
- Weight = 0.195 kg/piece

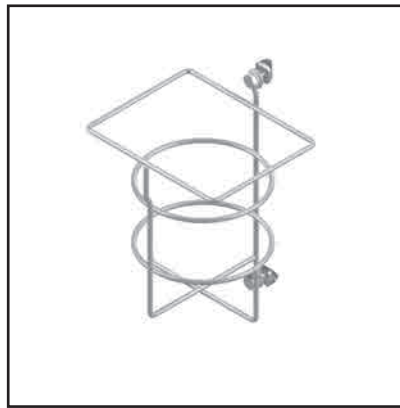
**APPLICATIONS**

- Commercially available beverage bottles and beverage bags

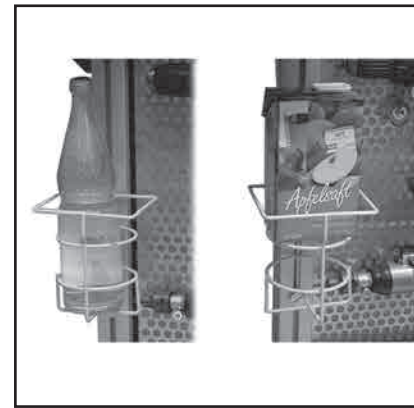
**ASSEMBLY**

- Screw down with fastening material

**WASTE SEPARATION**

Part no.

29.0022/0

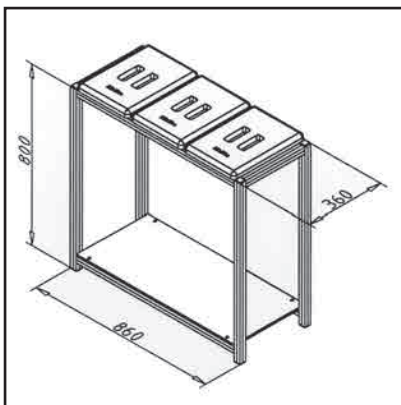
**TECHN. DATA / ITEMS SUPPLIED**

- Sturdy frame of profile 30 x 30, anodized E6 / EV1
- Delivery as construction set
- With shelf
- 3 covers ABS, grey
- Weight = 7.023 kg/piece

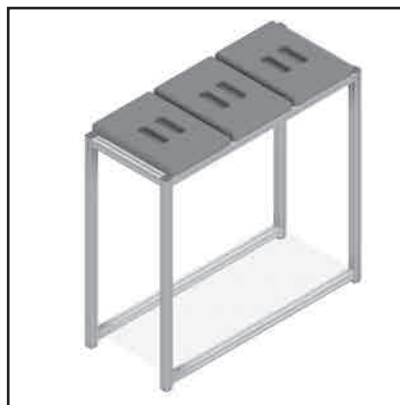
**APPLICATIONS**

- For separate collection of 3 kinds of recyclable materials
- Just put plastic bags over the screw heads
- Also suitable for outdoor deployment

**ASSEMBLY**

- According to enclosed installation instructions

## RECYCLABLE MATERIAL COLLECTOR FOR ATTACHMENT

Part no.

32.0024/0

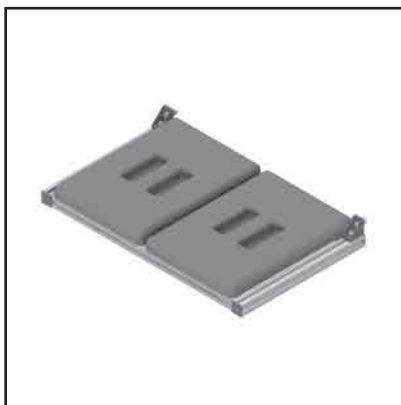
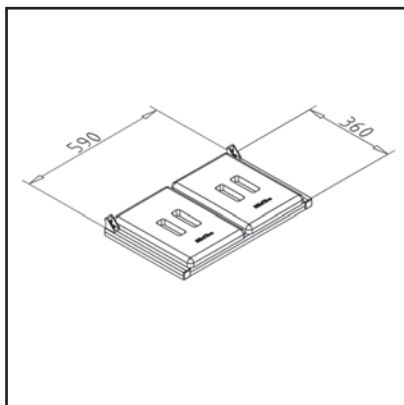

### TECHN. DATA / ITEMS SUPPLIED

- Frame made of profile 30 x 30, anodized E6 / EV1
- 2 covers ABS, grey
- 2 mounting angles 25
- Weight = 1.915 kg/piece

### APPLICATIONS

- For separate collection of 2 kinds of recyclable materials
- Just put plastic bags over the screw heads

### ASSEMBLY

- Attach to profile frame with fastening materials included

## TOOL CASE S AS SET

Part no.

26.3001/0

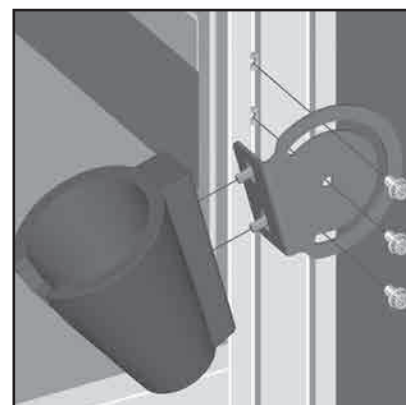
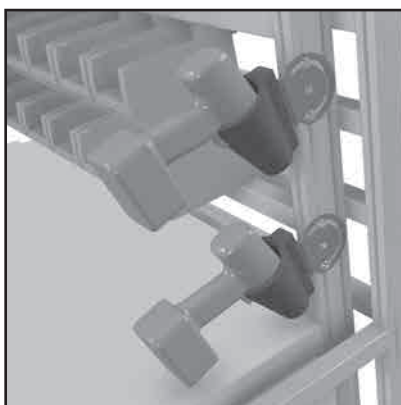
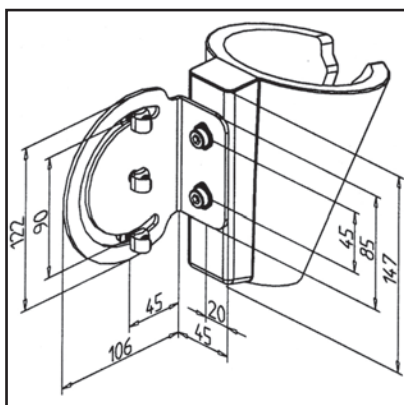

### TECHN. DATA / ITEMS SUPPLIED

- Tool quiver, rubber, black
- Swivel bracket, steel, grey, powder-coated
- With fastening material steel, zinc plated
- Weight = 0.830 kg/piece

### APPLICATIONS

- For secure storage of drills, battery-operated screwdrivers and other tools
- Adjustable angle

### ASSEMBLY

- Fasten to the profile brace with supplied hardware

### BASE SET TOOL CASE

Part no.

26.3004/0

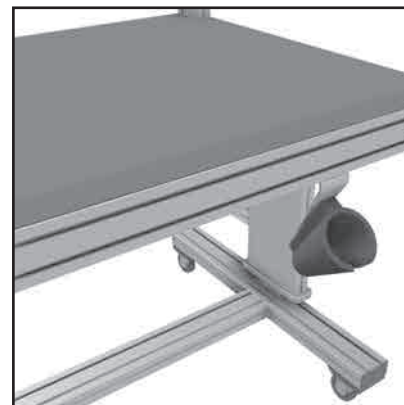
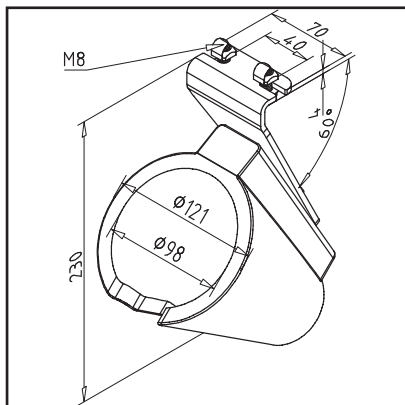

#### TECHN. DATA / ITEMS SUPPLIED

- Tool quiver, rubber, black
- Holder, stainless steel
- With fastening material steel, zinc plated
- Weight = 0.885 kg/piece

#### APPLICATIONS

- For secure storage of drills, battery-operated screwdrivers and other tools
- For ergonomic provision of tools below the work surface

#### ASSEMBLY

- Fasten to the profile brace with supplied hardware

### TOOL CASE S

Part no.

26.3001/1

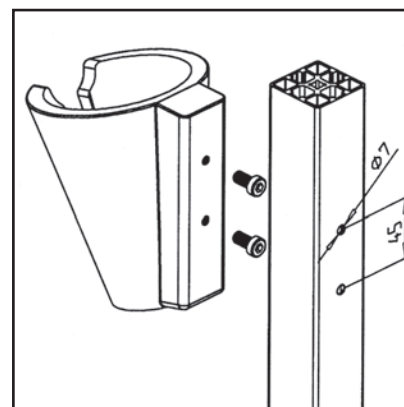
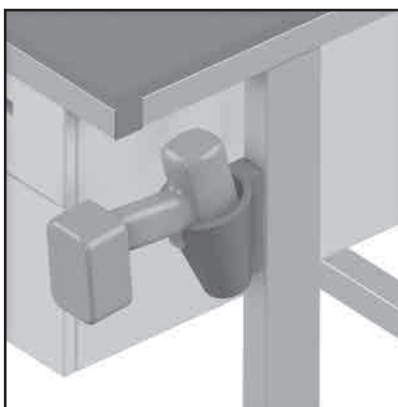
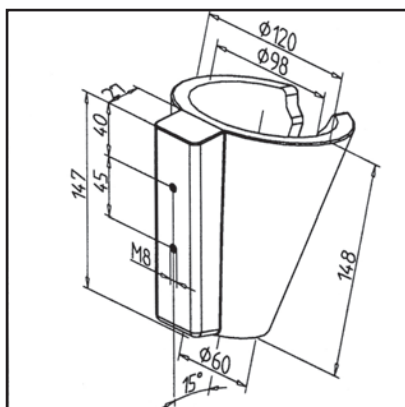

#### TECHN. DATA / ITEMS SUPPLIED

- Rubber, black
- Weight = 0.492 kg/piece

#### APPLICATIONS

- For secure storage of drills, battery-operated screwdrivers and other tools

#### ASSEMBLY

- Drill 2 bores  $\varnothing 7$  mm, distance of 45 into profile
- Fasten with screws M8 x 16



**ADAPTER FOR TOOL CASE**

Part no.

26.3002/0

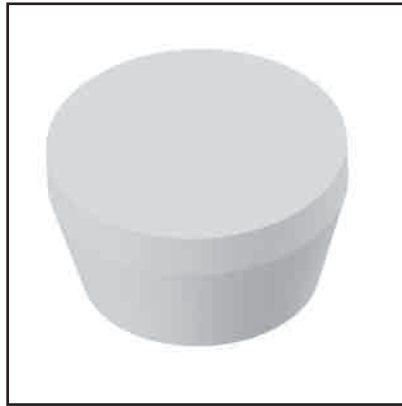
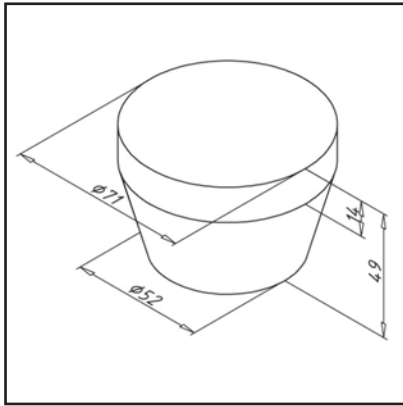
**TECHN. DATA / ITEMS SUPPLIED**

- POM, white
- Standard: without machining  
Optional: with machining eg. aptly drilled or milled for special tools
- Weight = 0.225 kg/piece

**APPLICATIONS**

- Adapter for rod screwdrivers, special screwdrivers, pneumatic screwdrivers and smaller hand tools

**ASSEMBLY**

- Press into tool quiver

**SWIVEL HOLDER**

Part no.

26.3001/2

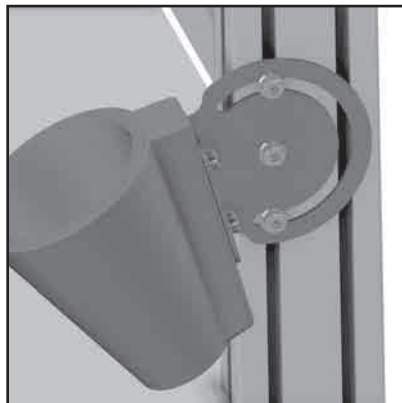
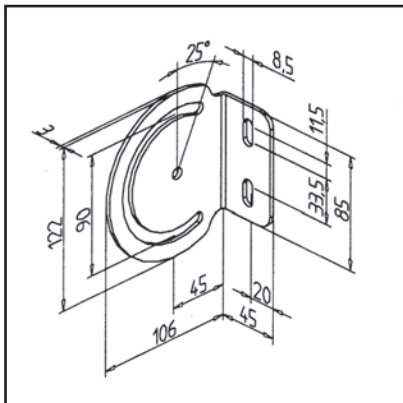
**TECHN. DATA / ITEMS SUPPLIED**

- Steel, powder-coated, grey
- Powder coated RAL 7012
- Weight = 0.283 kg/piece

**APPLICATIONS**

- For swiveling attachment of toolboxes, profiles or shelves

**ASSEMBLY**

- With screws M8 x 16 or clamping lever and M8 sliding nut

## SCREWDRIVER HOLDER

Part no.

32.0502/0

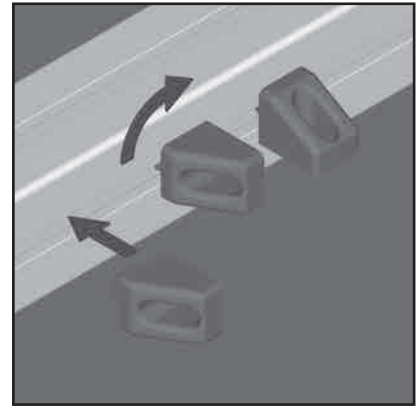
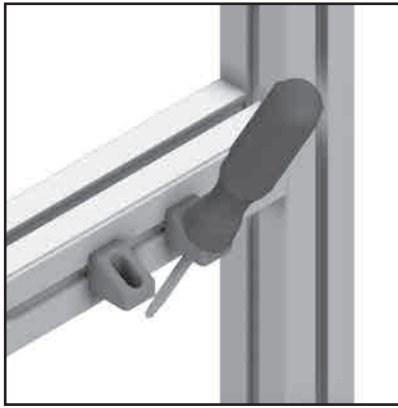
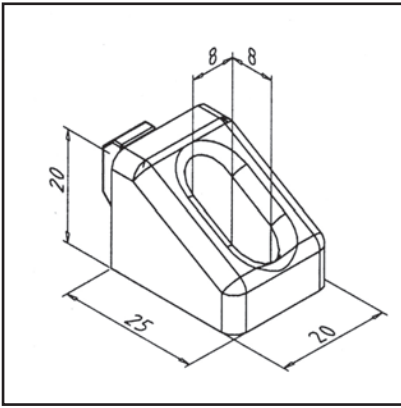

### TECHN. DATA / ITEMS SUPPLIED

- PA, Injection Mould, grey
- Weight = 0.006 kg/piece

### APPLICATIONS

- Ergonomic storage of screwdrivers at the workbench

### ASSEMBLY

- Push into the groove and then turn 90°

## BRUSH STRIP 30

Part no.

22.1150/0

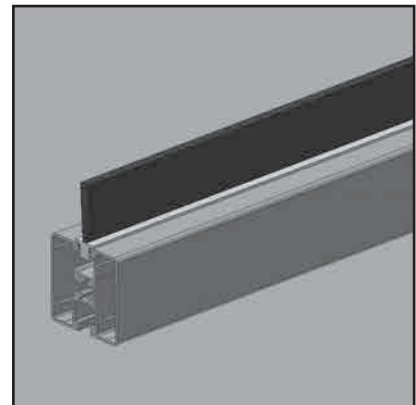
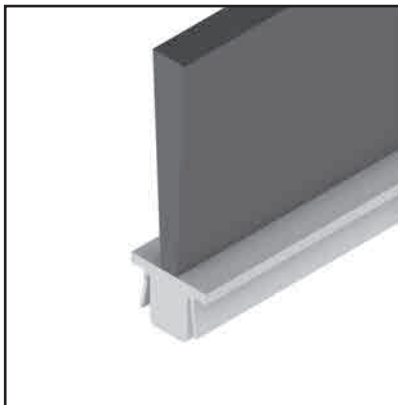
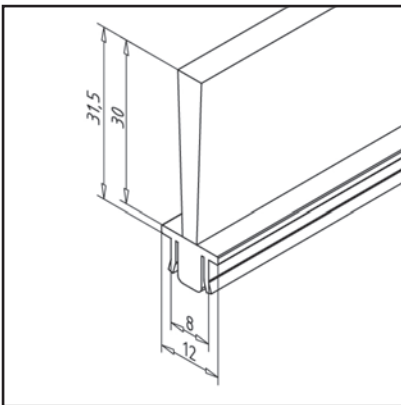

### TECHN. DATA / ITEMS SUPPLIED

- PVC strip with brush
- Manufacturing length: 1000 mm
- Weight = 0.128 kg/m

### APPLICATIONS

- Sealing of doors, lids
- Static strap cleaning in case of minor soiling
- Guiding and carrying in conveyor technology

### ASSEMBLY

- Insert or clip into profile groove

**VERTICAL DOUBLE OUTLET**

Part no.

32.0773/0

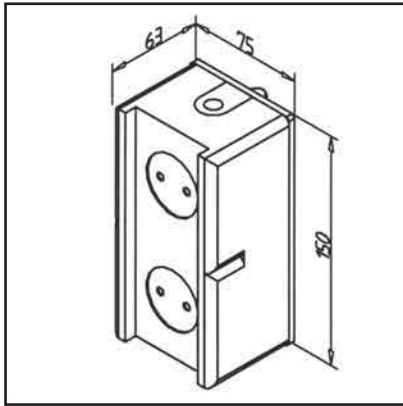
**TECHN. DATA / ITEMS SUPPLIED**

- Schuko 10 / 16 A 250 V
- IP 44 shatter-proof
- Housing 75 x 75 x 58 mm
- Fastening material
- With adapter plate and screws
- Weight = 0.389 kg/piece

**APPLICATIONS**

- For power supply at the workplace

**ASSEMBLY**

- Attach the adapter plate to the profile
- Fasten double outlet to the adapter plate

**HORIZONTAL DOUBLE OUTLET**

Part no.

32.0774/0

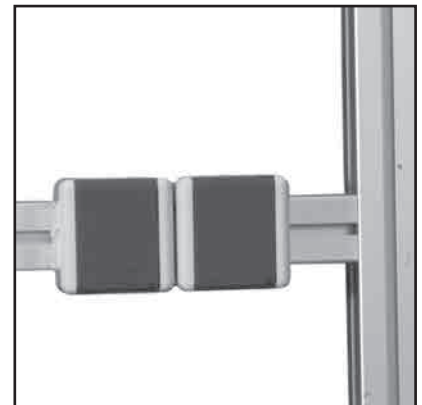
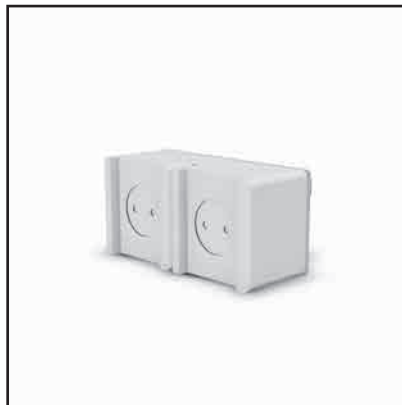
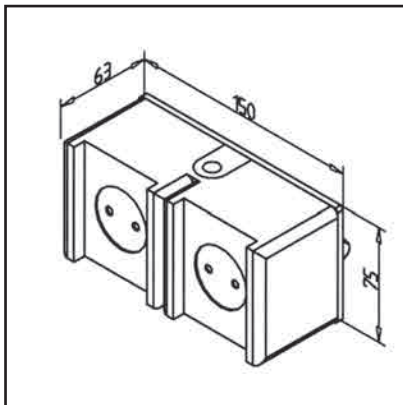
**TECHN. DATA / ITEMS SUPPLIED**

- Schuko 10 / 16 A 250 V
- IP 44 shatter-proof
- Housing 75 x 75 x 58 mm
- Fastening material
- With adapter plate and screws
- Weight = 0.389 kg/piece

**APPLICATIONS**

- For power supply at the workplace

**ASSEMBLY**

- Attach the adapter plate to the profile
- Fasten double outlet to the adapter plate

## POWER OUTLET

Part no.

32.0771/0

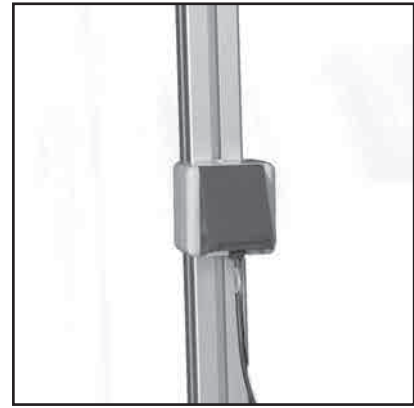
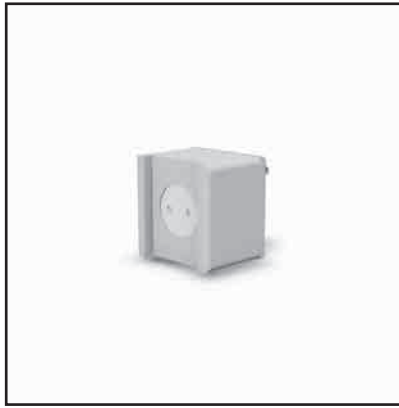
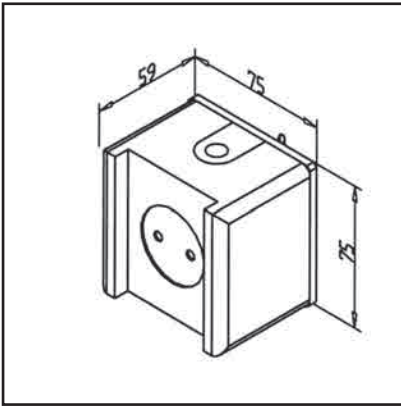

### TECHN. DATA / ITEMS SUPPLIED

- Schuko 10 / 16 A 250 V
- IP 44 shatter-proof
- Housing 75 x 75 x 58 mm
- With adapter plate and screws
- Weight = 0.211 kg/piece

### APPLICATIONS

- For power supply at the workplace

### ASSEMBLY

- Attach the adapter plate to the profile
- Fasten double outlet to the adapter plate

## TOGGLE SWITCH/POWER OUTLET

Part no.

32.0772/0

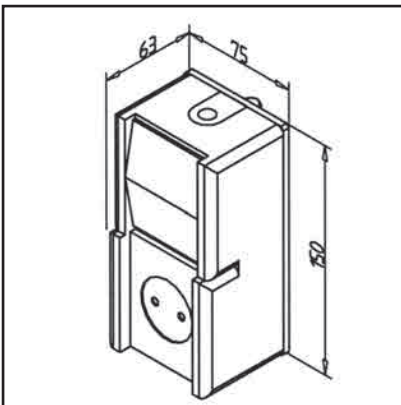

### TECHN. DATA / ITEMS SUPPLIED

- OFF switch, 10A x 250V
- Schuko 10 / 16 A 250 V, IP 44 shatter-proofed
- Housing 75 x 75 x 58 mm
- Fastening material
- With adapter plate
- Weight = 0.389 kg/piece

### APPLICATIONS

- For switching lights on and off

### ASSEMBLY

- Attach the adapter plate to the profile
- Fasten the switch on the adapter plate

**TOGGLE SWITCH**

Part no.

32.0770/0

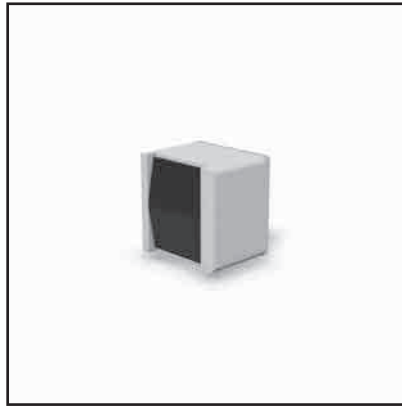
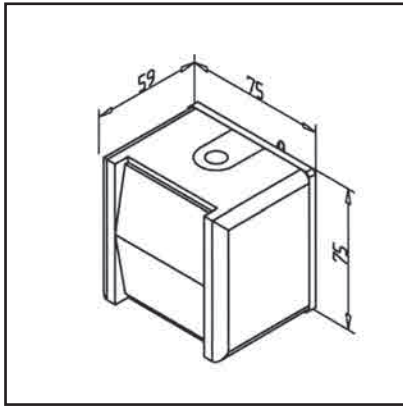
**TECHN. DATA / ITEMS SUPPLIED**

- OFF switch
- 10A x 250V
- Housing 75 x 75 x 58 mm
- Fastening material
- With adapter plate
  
- Weight = 0.211 kg/piece

**APPLICATIONS**

- For switching lights on and off

**ASSEMBLY**

- Attach the adapter plate to the profile
- Fasten the switch on the adapter plate

**SOCKET STRIPS 7-FOLD**

Part no.

32.0703/0

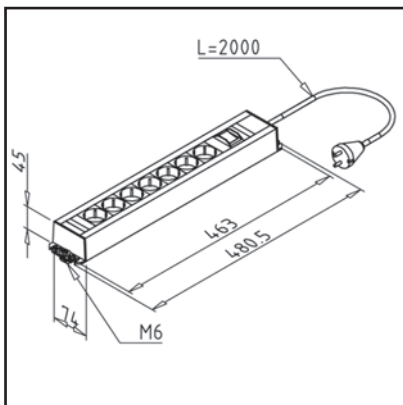
**TECHN. DATA / ITEMS SUPPLIED**

- 7-fold with additional switch
- Rocker switch, illuminated
- Cable length 2 m
- Max. 3500W / 16A / 230V
- Weight = 0.858 kg/piece

**APPLICATIONS**

- Oblique socket arrangement

**ASSEMBLY**

- Fasten to profile groove with supplied hardware

### SOCKET STRIP ALU 3-FOLD

Part no.

32.0704/0

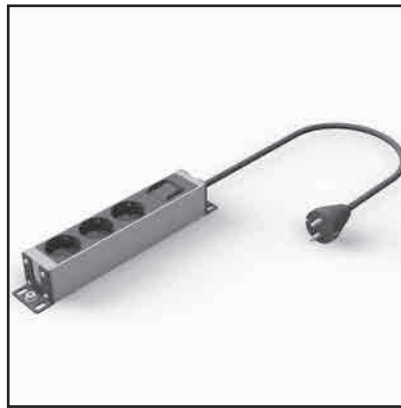
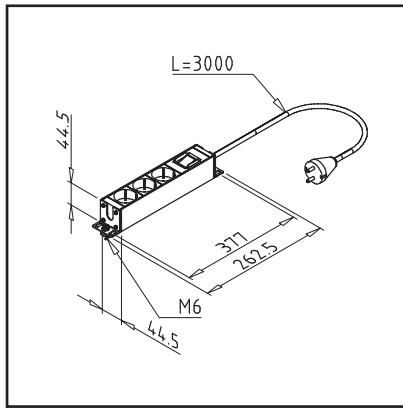

#### TECHN. DATA / ITEMS SUPPLIED

- Rocker switch, illuminated
- Max. 3500W / 16A / 230V
- Cable length 3 m
- Housing Aluminum natural anodized
- Weight = 0.718 kg/piece

#### APPLICATIONS

- Oblique socket arrangement

#### ASSEMBLY

- Fasten to profile groove with supplied hardware

### SOCKET STRIP ALU 6-FOLD

Part no.

32.0705/0

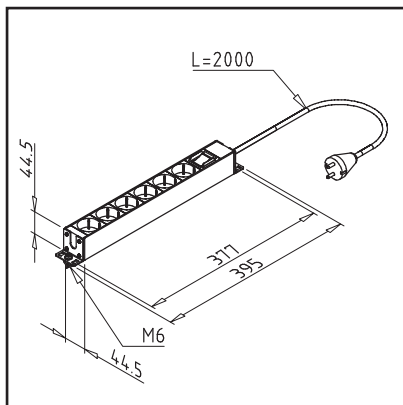

#### TECHN. DATA / ITEMS SUPPLIED

- Housing Aluminum natural anodized
- Rocker switch, illuminated
- Max. 3500W / 16A / 230V
- Cable length 2 m
- Weight = 0.848 kg/piece

#### APPLICATIONS

- Oblique socket arrangement

#### ASSEMBLY

- Fasten with fastening material to profile groove

**SOCKET STRIP ALU 8-FOLD**

Part no.

32.0706/0

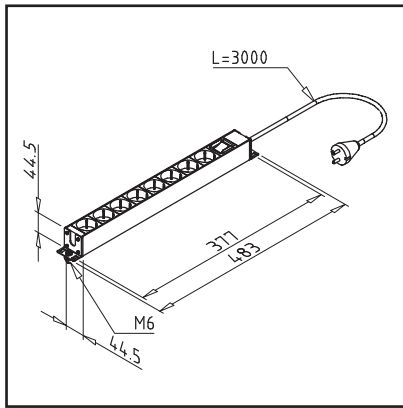
**TECHN. DATA / ITEMS SUPPLIED**

- Rocker switch, illuminated
- Max. 3500W / 16A / 230V
- Cable length 3 m
- Housing Aluminum natural anodized
- Weight = 0.848 kg/piece

**APPLICATIONS**

- Oblique socket arrangement

**ASSEMBLY**

- Fasten to profile groove with supplied hardware