

ADJUSTING UNIT VEW 90

Part no. 28.0183/0

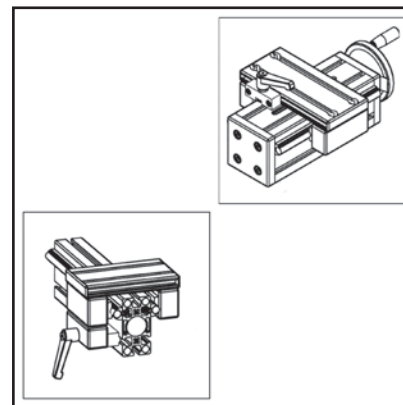
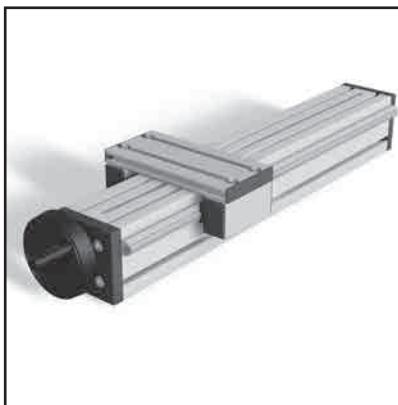
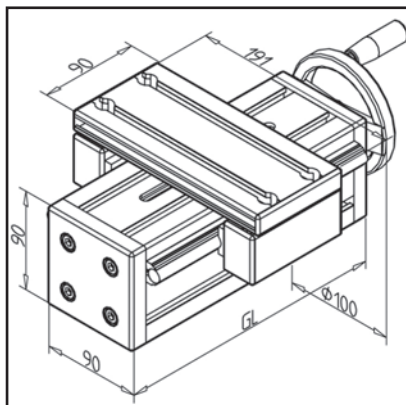

TECHN. DATA / ITEMS SUPPLIED

APPLICATIONS

OTHER VERSIONS

- Aluminium, anodized E6/EV1
- Slide plate of profile 19 x 90
- Spindle 16 x 4
- Basic length (GL) 120 mm (0 mm stroke)
- **Please indicate desired length of stroke**
- Weight = (basic weight) 3.03 kg
- Extra weight = 1.12 kg/100mm stroke

- Adjustment of conveyors
- Adjustment of feeders
- Adjustable devices

- Slide plate made of profile 32 x 180
- Deviating wagon length
- Digital display
- Angular drive
- Spindle cover
- Shafts stainless
- Options:
With carriage clamp up **part no. 28.0183/1**
With carriage clamping laterally **part no. 28.0183/2**

ADJUSTING UNIT VEW 45X90 F

Part no. 28.0181/0

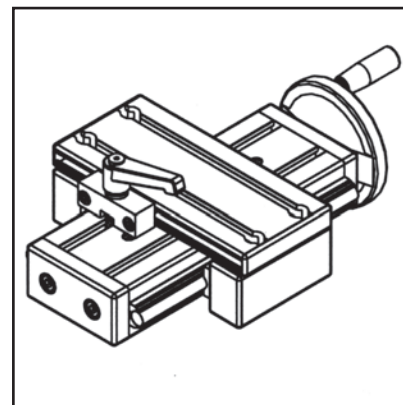
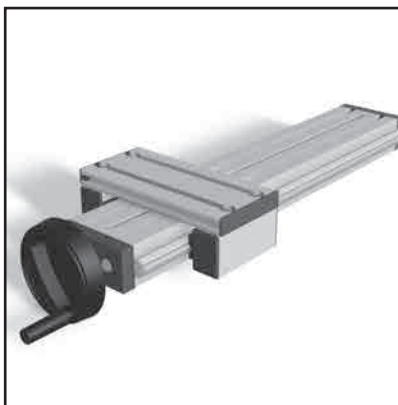
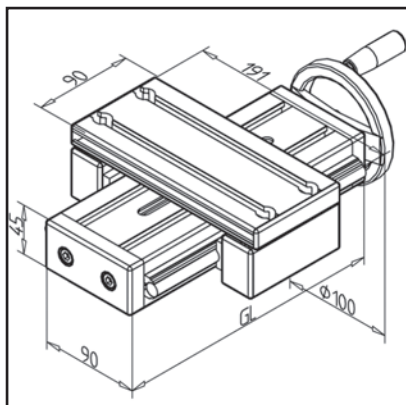

TECHN. DATA / ITEMS SUPPLIED

APPLICATIONS

OTHER VERSIONS

- Aluminium, anodized E6/EV1
- Slide plate of profile 19 x 90
- Spindle 16 x 4
- Basic length (GL) 120 mm (0 mm stroke)
- **Please indicate desired length of stroke**
- Weight = (basic weight) 2.31 kg
- Extra weight = 0.75 kg/100mm stroke

- Adjustment of conveyors
- Adjustment of feeders
- Adjustable devices

- Slide plate made of profile 32 x 180
- Deviating wagon length
- Digital display
- Angular drive
- Spindle cover
- Shafts stainless
- OPTIONS: With slide clamping device at top **part no. 28.0181/1**

ADJUSTING UNIT VEW 45X90 H

Part no.

28.0182/0

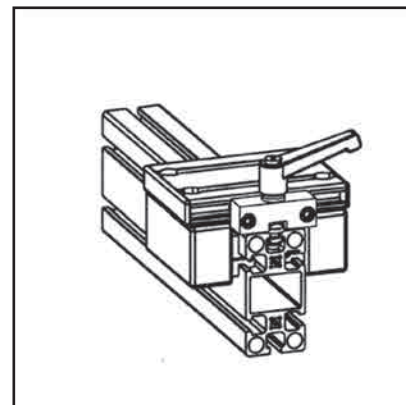
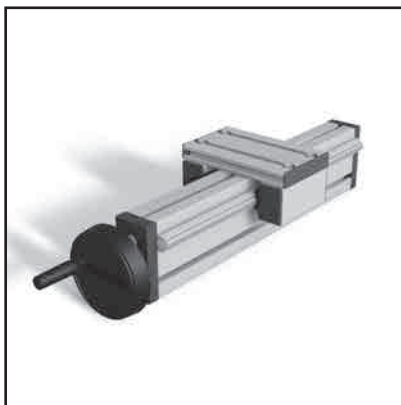
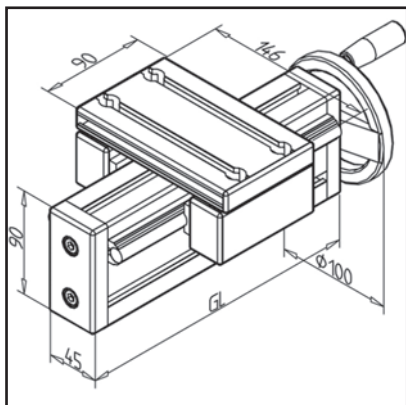
**TECHN. DATA / ITEMS SUPPLIED**

- Aluminium, anodized E6/EV1
- Slide plate of profile 19 x 90
- Spindle 16 x 4
- Basic length (GL) 120 mm (0 mm stroke)
- **Please indicate desired length of stroke**
- Weight = (basic weight) 2.109 kg
- Extra weight = 0.74 kg/100mm stroke

APPLICATIONS

- Adjustment of conveyors
- Adjustment of feeders
- Adjustable devices

OTHER VERSIONS

- Slide plate made of profile 32 x 180
- Deviating wagon length
- Digital display
- Angular drive
- Shafts stainless
- Options:
With carriage clamp up **part no. 28.0182/1**
With clamping laterally **part no. 28.0182/2**

ADJUSTING UNIT VEN 45X90S

Part no.

28.0187/0

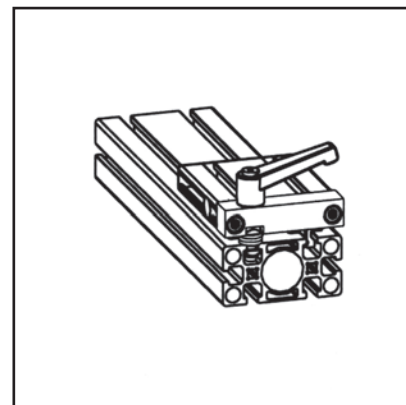
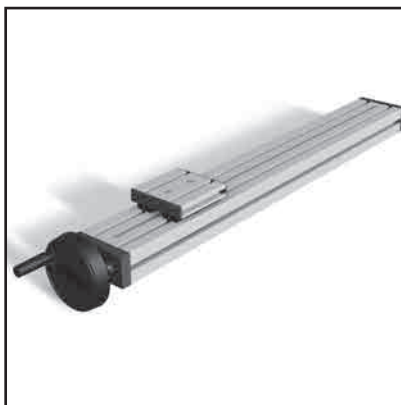
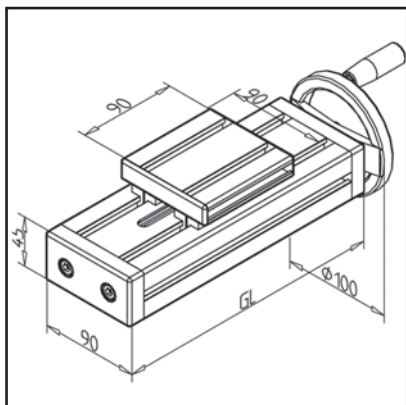
**TECHN. DATA / ITEMS SUPPLIED**

- Aluminium, anodized E6/EV1
- Slide plate of profile 19 x 90
- Spindle 16 x 4
- Basic length (GL) 120 mm (0 mm stroke)
- **Please indicate desired length of stroke**
- Weight = (basic weight) 2.280 kg
- Extra weight = 0.5 kg/100mm stroke

APPLICATIONS

- Adjustment of conveyors
- Adjustment of feeders
- Adjustable devices

OTHER VERSIONS

- Slide plate made of profile 32 x 180
- Deviating wagon length
- Digital display
- Angular drive
- Options:
With slide clamping unit (Top) **part no. 28.0187/1**

ADJUSTING UNIT VEN 90

Part no. 28.0186/0

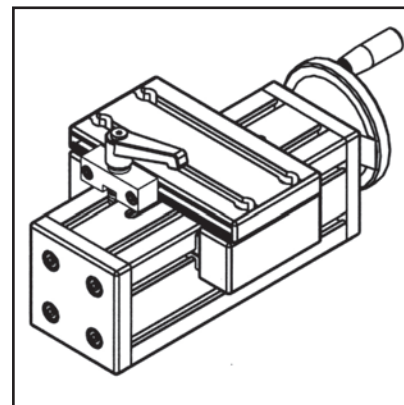
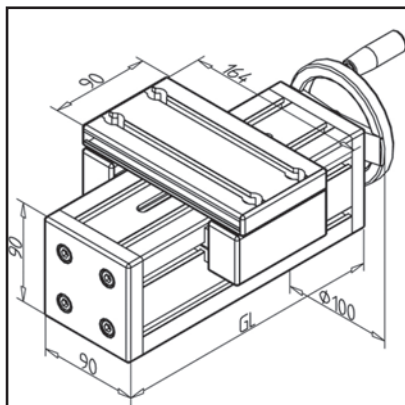

TECHN. DATA / ITEMS SUPPLIED

- Aluminium, anodized E6/EV1
- Slide plate of profile 19 x 90
- Spindle 16 x 4
- Basic length (GL) 120 mm (0 mm stroke)
- **Please indicate desired length of stroke**
- Weight = (basic weight) 2.75 kg
- Extra weight = 0.87 kg/100mm stroke

APPLICATIONS

- Adjustment of conveyors
- Adjustment of feeders
- Adjustable devices

OTHER VERSIONS

- Slide plate made of profile 32 x 180
- Deviating wagon length
- Digital display
- Angular drive
- Spindle cover
- Options:
- With carriage clamp up **part no. 28.0186/1**
- With carriage clamping laterally **part no. 28.0186/2**

ADJUSTING UNIT VEN 45X90

Part no. 28.0188/0

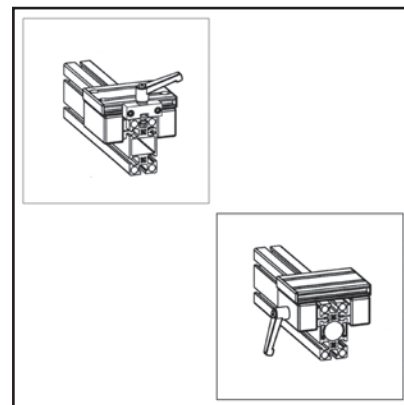
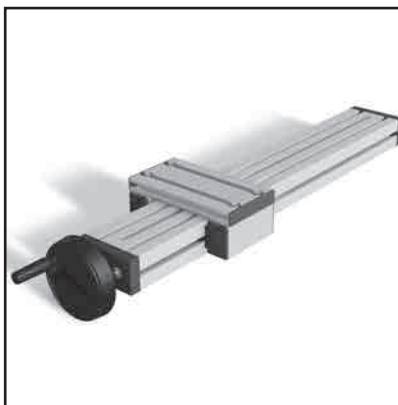
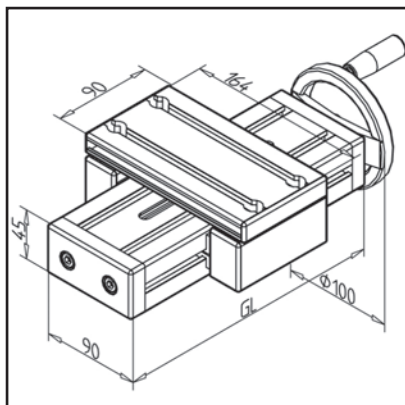

TECHN. DATA / ITEMS SUPPLIED

- Aluminium, anodized E6/EV1
- Slide plate of profile 19 x 90
- Spindle 16 x 4
- Basic length (GL) 120 mm (0 mm stroke)
- **Please indicate desired length of stroke**
- Weight = (basic weight) 2.05 kg
- Extra weight = 0.5 kg/100mm stroke

APPLICATIONS

- Adjustment of conveyors
- Adjustment of feeders
- Adjustable devices

OTHER VERSIONS

- Slide plate made of profile 32 x 180
- Deviating wagon length
- Digital display
- Angular drive
- Spindle cover
- Options:
- With carriage clamp up **part no. 28.0188/1**
- With carriage clamping laterally **part no. 28.0188/2**

ADJUSTING UNIT VEN 45X90 H

Part no.

28.0185/0

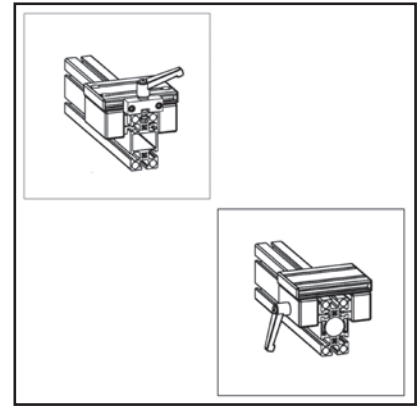
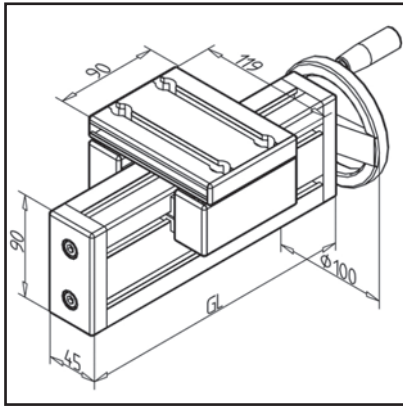
**TECHN. DATA / ITEMS SUPPLIED**

- Aluminium, anodized E6/EV1
- Slide plate of profile 19 x 90
- Spindle 16 x 4
- Basic length (GL) 120 mm (0 mm stroke)
- **Please indicate desired length of stroke**
- Weight = (basic weight) 1.97 kg
- Extra weight = 0.49 kg/100mm stroke

APPLICATIONS

- Adjustment of conveyors
- Adjustment of feeders
- Adjustable devices

OTHER VERSIONS

- Slide plate made of profile 32 x 180
- Deviating wagon length
- Digital display
- Angular drive
- Options:
 - With carriage clamp up **part no. 28.0185/1**
 - With carriage clamping laterally **part no. 28.0185/2**