



G 90

POSITIONING SYSTEM

FOR LIFT APPLICATIONS

UPWARD WITH A **SYSTEM APPROACH**

Lift systems are gaining more and more importance in our social life. Starting with the new GG90 and GDG90, Bahr Modultechnik launches a new product line that reliably meets the requirements of lift systems.

These systems are already in use at workplaces, in the assistance of wheelchair users at buildings and in vehicles and in many other applications where heavy loads have to be lifted up.

About us: Bahr Modultechnik has been a globally leading manufacturer of linear modules since 1990. Based on an innovative product policy, we produce high-quality products tailored to our customers needs. Our efficiency is characterized by optimal production operations, qualified personnel, permanent service readiness and further development.

We use our experience and competencies to meet your requirements. With more than 10,000 projects realized in various industries, we always strive to collaborate on a trustful and long-term basis with our customers and partners.

Customer satisfaction is our motor and our motivation. We develop customized and user-friendly solutions for every set of requirements, from individual parts up to serial production.

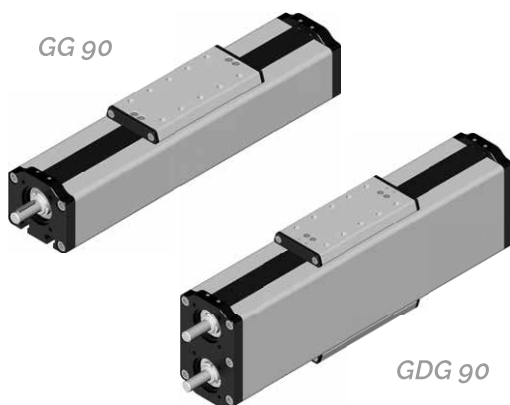

The guide bodies of our positioning systems consist of aluminium square profiles with edge lengths of 90 mm; the carriage inside the square profile is driven by a spindle with a corresponding lead nut.

To reduce friction, large slide bushes made of plastic are integrated into the carriage, ensuring smooth running with low noise and minimum wear.



ScooterLift

Applications



Wheelchair lift



Bicycle lift



 **BAHR**
Modultechnik

Bahr Modultechnik GmbH
Nord-Süd-Str. 10a - D-31711 Luhden
Telefon +49 (0) 5722 - 99 33-0
www.bahr-modultechnik.de