

KANBAN-SYSTEM

Low inventory and loss prevention are continual challenges of series production. These goals can be reached by simple means using consumption-controlled material handling methods according to the Kanban principle. In this, the parts required in production by the consumptive positions in the production cycle are requested by a simple Kanban card from the upstream step. Normally the card is located at the material and triggers a production order when reaching the minimum inventory. To ensure the consumption-controlled production and therefore the minimisation of inventory, no order can be started without this Kanban card.

Provision of the products is done directly at the point of consumption in so-called Kanban shelves. These shelves are equipped with inclined small roller conveyors, which transport the containers or products to the receiving station by gravity. Shelf stocking is done from the rear. The size of the shelves is depending on the supply at the workplace determined according to Kanban rules.

So that the containers can be transported securely and protected into the shelving, the incline of the roller conveyor can be simply adjusted. Brake blades are available to prevent impact damage and are easy to install. The use of these brake blades is especially necessary for heavy weights..

We supply all required components for the construction of custom-built Kanban shelves.

Our KanTainer (part no. 32.0870 / 0) is particularly suitable for the management of small parts according to the Kanban principle.



PULLEY D 25

part no. 21.1701/0

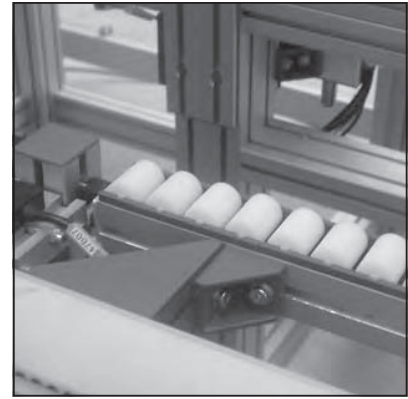
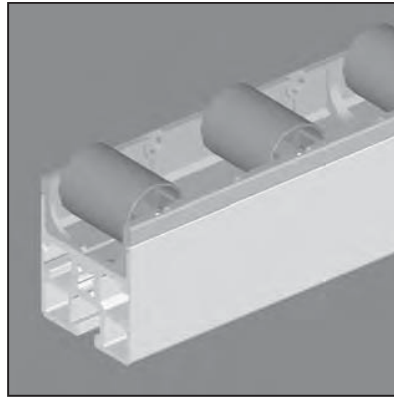
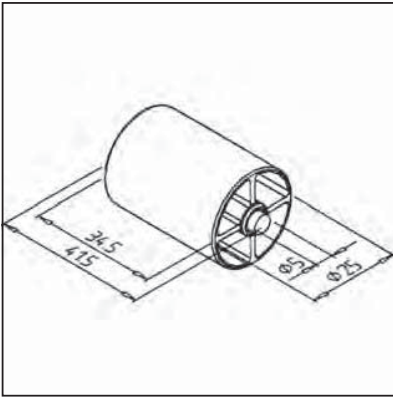

TECHN. DATA / ITEMS SUPPLIED

- ABS, blue
- Axe Ø 5, stainless steel
- Weight 0,01 kg
- Load max/roller 20 N
- For higher loads use Pulley D 25 compact part no. 21.1703/0

APPLICATIONS

- Assembly of small roller conveyors in connection with profile 45 x 45 R part no. 20.1046/0

ASSEMBLY

- Clip pulleys into pulley carrier

RETURN STOP

part no. 32.0586/0

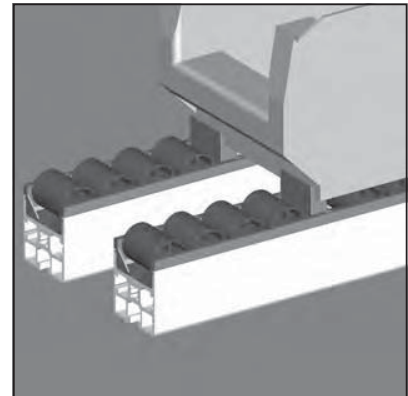
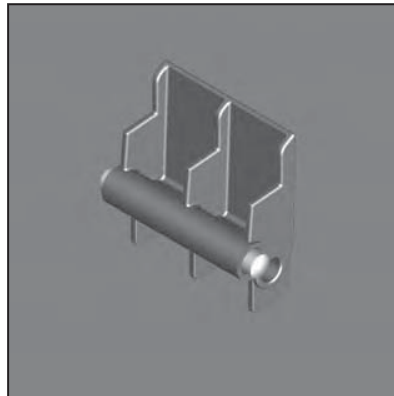
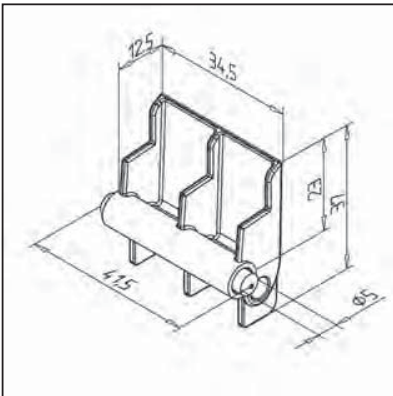

TECHN. DATA / ITEMS SUPPLIED

- ABS, grey
- Weight 0,015 kg

APPLICATIONS

- used for decline-roller conveyors to prevent transported material from running back
- in combination with pulley carrier 45x45R

ASSEMBLY

- clip into roller instead of pulley carrier

SLIDING INSERT FOR ROLLER CARRIER

part no. 21.0940/0

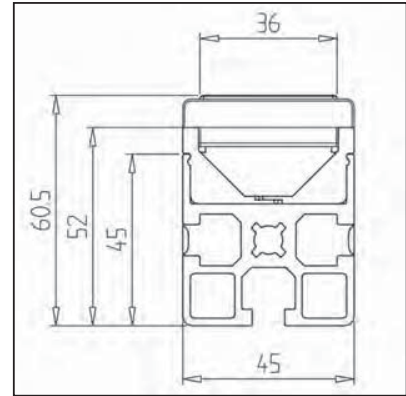
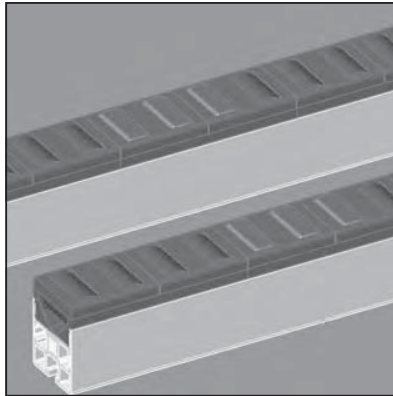
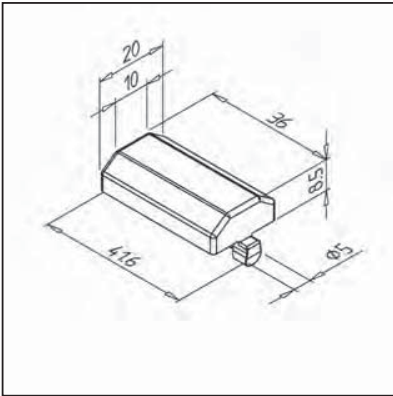

TECHN. DATA / ITEMS SUPPLIED

- POM, grey RAL 7012
- Suitable for roller carrier
- Weight 0,04 kg

APPLICATIONS

- For insertion in roller carriers instead of pulley D 25, for slowdown of transported material
- To prevent a roll away on the installation site

ASSEMBLY

- Clip into roller carrier instead of pulley

ROLLER CARRIER 45 X 45 R WITH CAP

part no. 22.1151/0

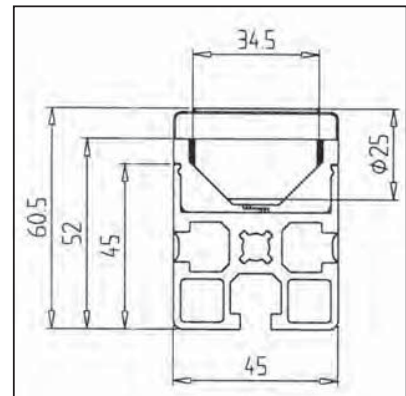
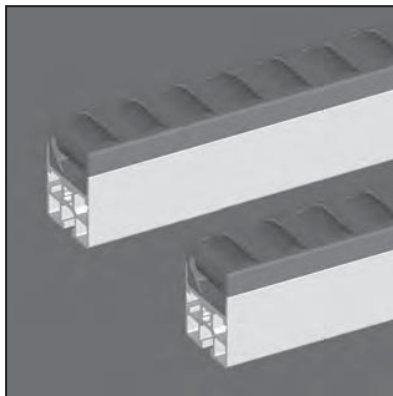
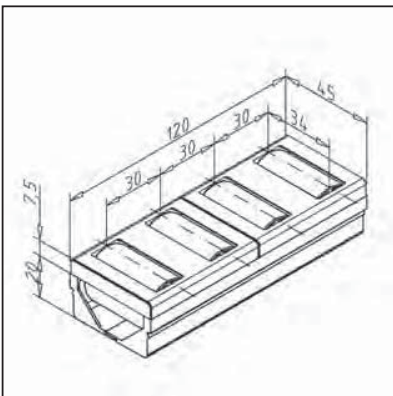

TECHN. DATA / ITEMS SUPPLIED

- 2x roller carrier basic component POM-RAL 7012, **part no. 22.1126/0**
- 1x cap POM-RAL 7012 - part no. 22.1127/0
- 4x carrier roller ABS blue, **part no. 21.1701/0**
- Weight 0,076 kg
- Length 120 mm

APPLICATIONS

- Production of shortrollrails in connection with profile 45 x 45 R, **part no. 20.1046/0**

ASSEMBLY

- Insert roller carrier in profile
- Insert carrier roller in profile
- Clipoff cap

ROLLER CARRIER 45 X 45 R WITH SF CAP

part no. 22.1152/0

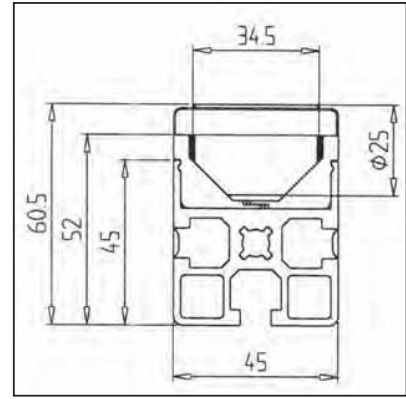
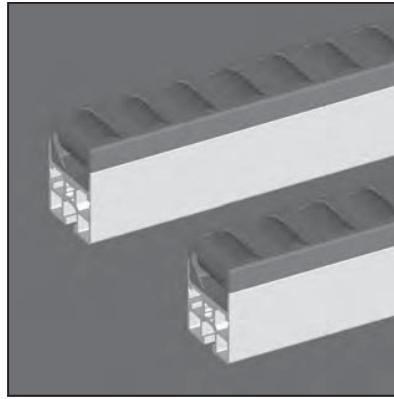
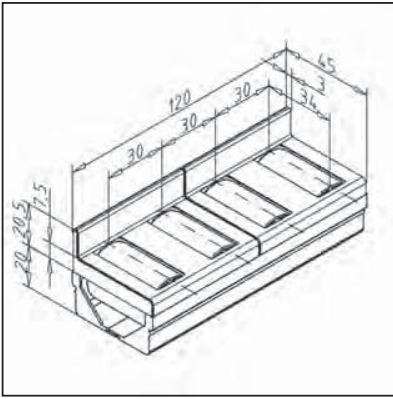

TECHN. DATA / ITEMS SUPPLIED

- 2x roller carrier basic component POM-RAL 7012, **part no. 22.1126/0**
- 1x cap POM-RAL 7012 - part no. 22.1128/0
- 4x carrier roller ABS blue, **part no. 21.1701/0**
- Weight 0,083 kg
- Length 120 mm

APPLICATIONS

- Production of shortrollrail in connection with profile 45 x 45 R, **part no. 20.1046/0**

ASSEMBLY

- Insert roller carrier in profile
- Insert carrier roller in profile
- Clipoff cap

CARRIER SECTION 45 R

part no. 20.1133/0

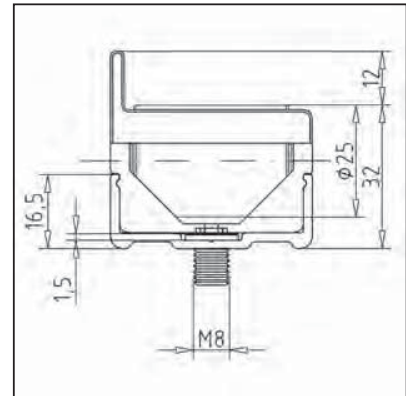
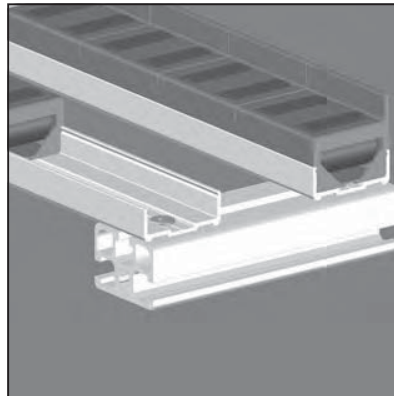
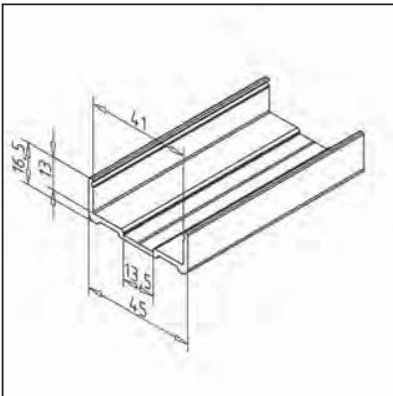

TECHN. DATA / ITEMS SUPPLIED

- $I_x = 0,289 \text{ cm}^4$
- $I_y = 0,428 \text{ cm}^4$
- $W_x = 0,128 \text{ cm}^3$
- $W_y = 0,966 \text{ cm}^3$
- Weight 0,414 kg/m
- Length 6 m

APPLICATIONS

- For Production of shortrollrails
- For use of the follow roller carrier **part no. 21.1700/0** roller carrier 45 x 45 with cap **part no. 22.1151/0** roller carrier 45 x 45R with SF cap **part no. 22.1152/0** roller carrier 45 x 45R with SF cap

ASSEMBLY

- Bore $\phi 8,5$ bring in desired positions
- With flat headed screw **part no. 21.1666/0** and slide nut M08 with spring steel sheet **part no. 21.1351/2**
- Put in desired roller carrier

ROLLER STRIP WITH CYLINDRICAL ROLLERS

part no. 32.0550/0

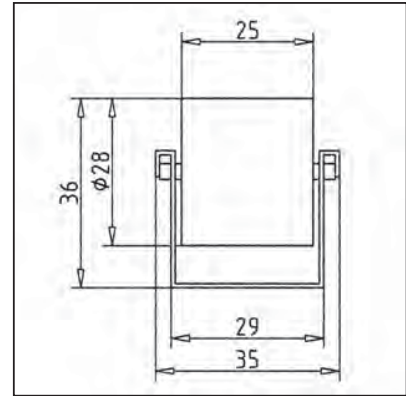
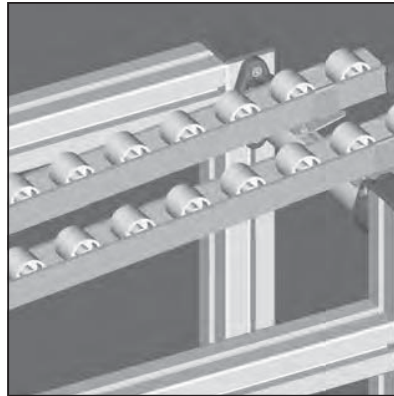
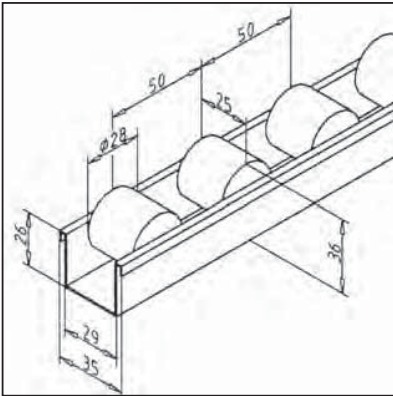

TECHN. DATA / ITEMS SUPPLIED

- Length according to costumers specification	
- Max. length	6000 mm
- Division	50 mm
- Supporting profile: Steel, zinc plated	
- Roller colour: yellow	
- Weight	0,595 kg/m

APPLICATIONS

- The rollers can be used over a temperature range from -30°C up to +100°C
- **part no. 32.0555/0** highly conductive roller to avoid electrostatic charge. Roller colour: black

ASSEMBLY

- Fasten with fastening **part no. 32.0574/0** and end stop **part no. 32.0569/0** onto profile
- Directly on carrier profile

ROLLER STRIP WITH FLANGED ROLLERS

part no. 32.0560/0

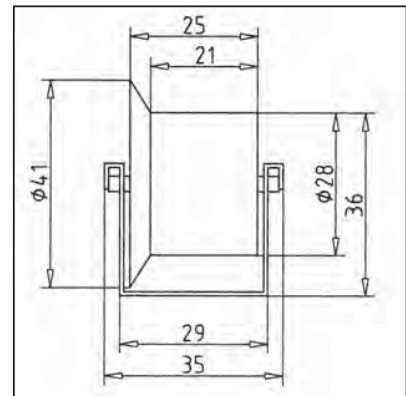
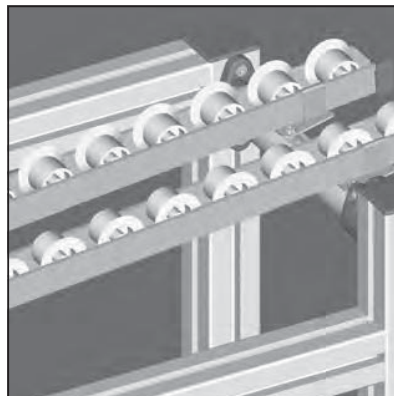
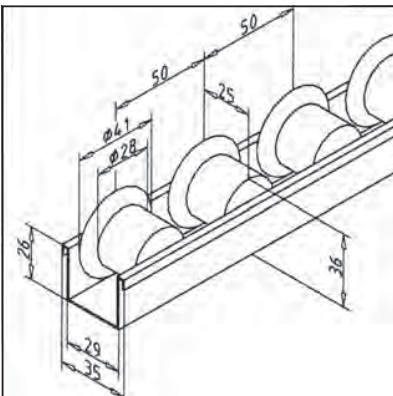

TECHN. DATA / ITEMS SUPPLIED

- Length acc. to customer specification	
- Max. length	6000 mm
- Division	50 mm
- Supporting profile: Steel, zinc plated	
- Roller colour: yellow	
- Weight	0,615 kg/m

APPLICATIONS

- The rollers can be used over a temperature range from -30°C up to +100°C
- **part no. 32.0565/0** highly conductive roller to avoid electrostatic charge. Roller colour: black

ASSEMBLY

- Fasten with fastening **part no. 32.0574/0** and end stop **part no. 32.0569/0** onto profile
- Directly on carrier profile

ROLLER STRIP BRACKET 30

part no. 32.0575/1

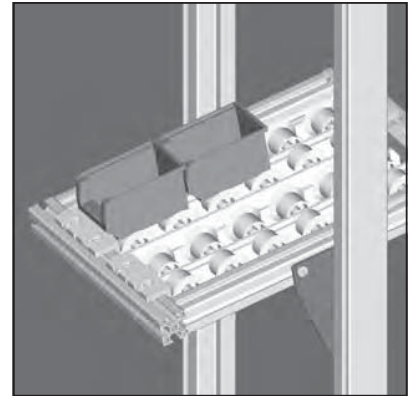
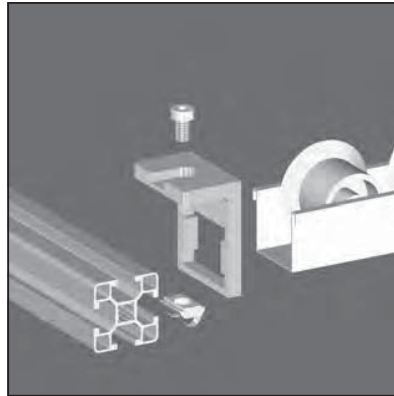
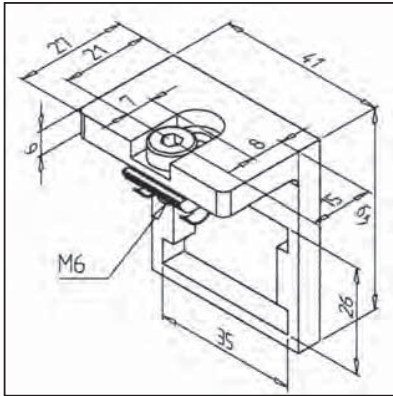
**TECHN. DATA / ITEMS SUPPLIED**

- Steel, zinc plated	
- With fastening kit	
- Thickness	6 mm
- Weight	0,092 kg

APPLICATIONS

- For fastening of roller strips

ASSEMBLY

- Shorten roller strips
- Clip roller strip bracket onto roller strip and use fastening kit

ROLLER STRIP FASTENING

part no. 32.0574/0

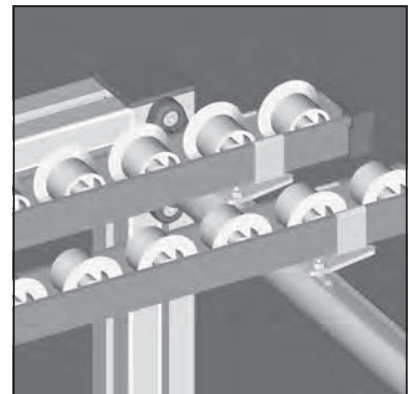
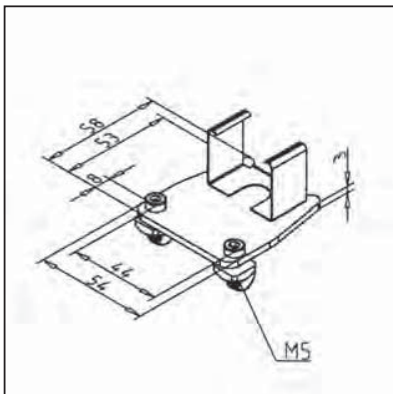
**TECHN. DATA / ITEMS SUPPLIED**

- Fixing plate steel VA	
- Thickness	3 mm
- With the fastening kit and spring clamps for roller strip	
- Weight	0,078 kg/m

APPLICATIONS

- for fastening roller strip without processing

ASSEMBLY

- For inclining roller tracks, handle profile **part no. 20.1088/0** connected to a flange bearing 32 **part no. 22.1016/0** or use a collar 32 **part no. 22.1022/0**

ROLLER STRIP END STOP

part no. 32.0569/0

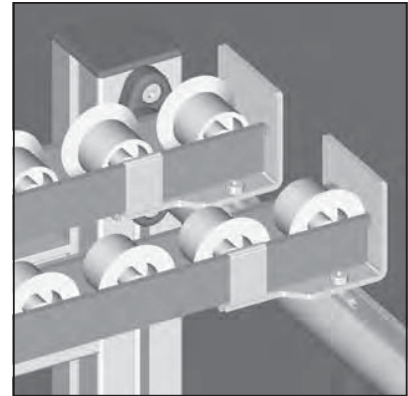
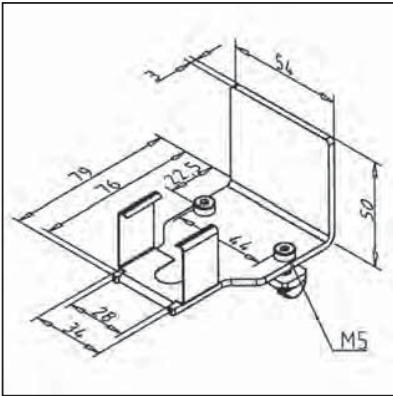

TECHN. DATA / ITEMS SUPPLIED

- Stainless steel end stop
- Thickness 3 mm
- with the fastening kit and spring clamps for roller strip
- Weight 0,166 kg/m

APPLICATIONS

- Use as end stop for roller strip
- Install without drilling

ASSEMBLY

- Use fastening kit
- For inclining roller tracks, handle profile **part no. 20.1088/0** connected to a flange bearing 32 **part no. 22.1016/0** or use a collar 32 **part no. 22.1022/0**

ROLLER STRIP BRACKET H

part no. 32.0553/0

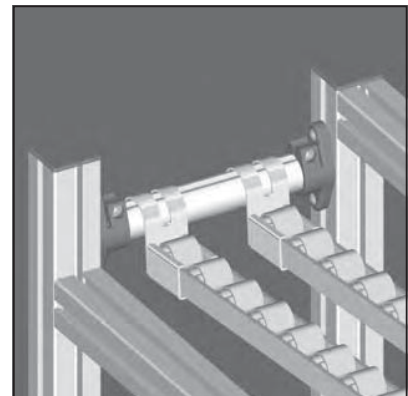
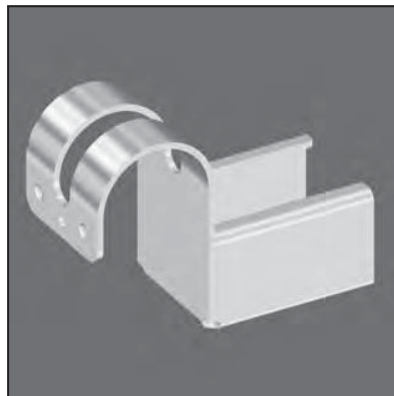
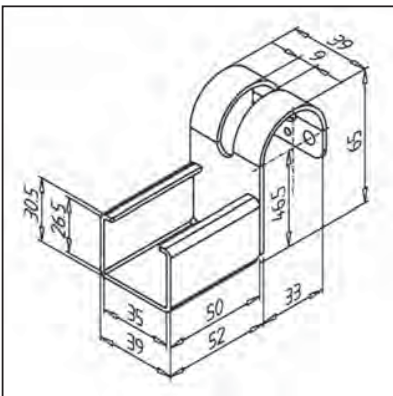

TECHN. DATA / ITEMS SUPPLIED

- steel, zinc-plated
- Thickness 2 mm
- Weight 0,141 kg

APPLICATIONS

- for fastening roller strips onto handle profile 32
- used as end stop for e.g. containers

ASSEMBLY

- shorten roller strips
- clip roller strip bracket onto roller strip
- hook into handle profile 32
- if necessary secure roller strip bracket with stud screws

ROLLER STRIP BRACKET F

part no. 32.0554/0

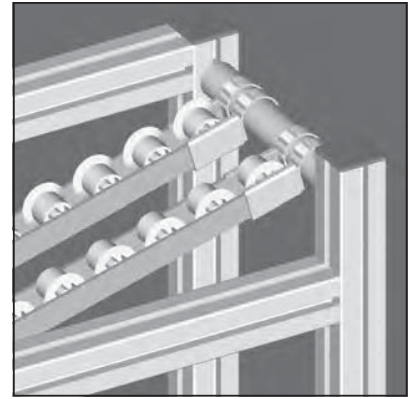
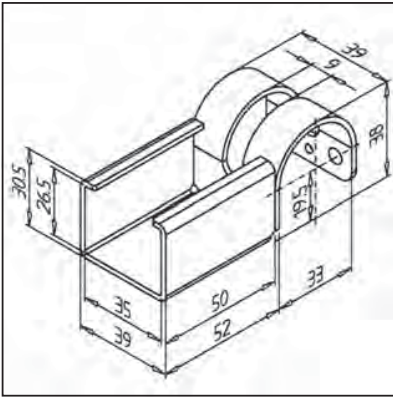

TECHN. DATA / ITEMS SUPPLIED

- Steel zinc plated	
- Thickness	2 mm
- Weight	0,124 kg

APPLICATIONS

- for fastening roller strips onto handle profile 32
- Height of edges on the bracket corresponds the travelling height of rollers

ASSEMBLY

- shorten roller strips
- clip roller strip bracket onto roller strip
- hook into handle profile 32
- if necessary secure roller strip bracket with stud screws

ROLLER STRIP BRACKET 19

part no. 32.0575/0

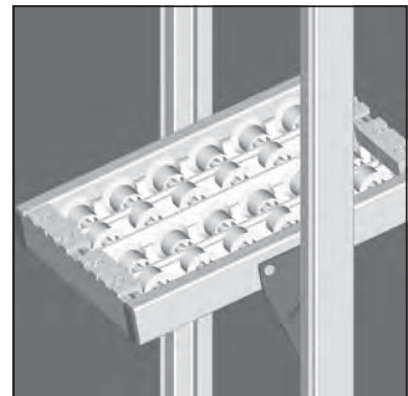
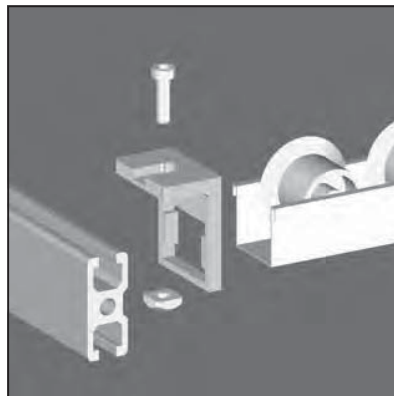
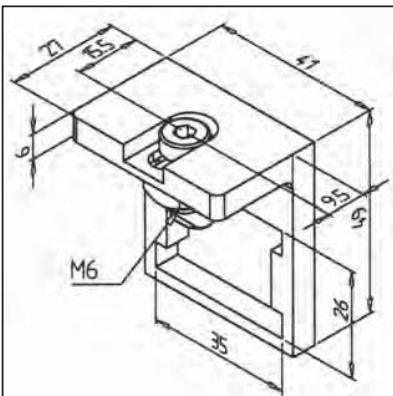

TECHN. DATA / ITEMS SUPPLIED

- Steel zinc plated	
- With fastening kit	
- Thickness	6 mm
- Weight	0,096 kg

APPLICATIONS

- for fastening roller strips onto profiles series 19 and 32
- Holder also serves as bedstop
- also available for profile 30 serie (see **part no. 32.0575/1**)

ASSEMBLY

- shorten roller strips
- clip roller strip into bracket and use supplied fastening kit to fasten onto profile

FLANGE BEARING 32

part no. 22.1016/0

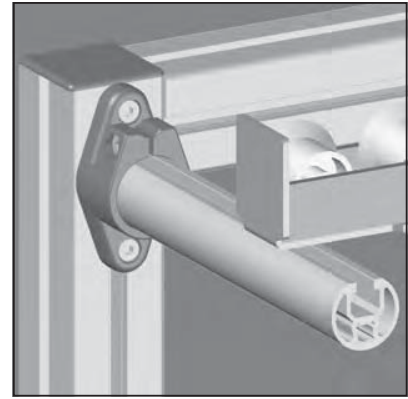
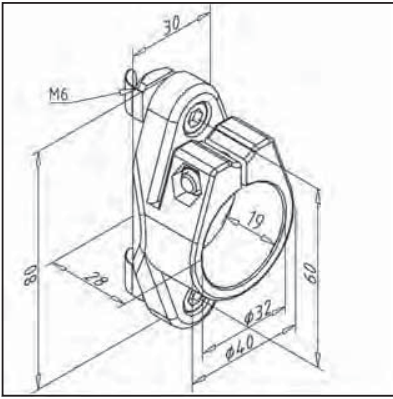

TECHN. DATA / ITEMS SUPPLIED

- Flange bearing ABS, grey
- With fastening kit
- Weight 0,050 kg

APPLICATIONS

- For angle adjustable installation of handle profile 32 for roller strip

ASSEMBLY

- Use fastening kit to fasten to base frame
- Push in handle profile 32 and clamp using screws
- Assembly without drilling

STRAP HANDLE PROFILE 32

part no. 22.1022/0

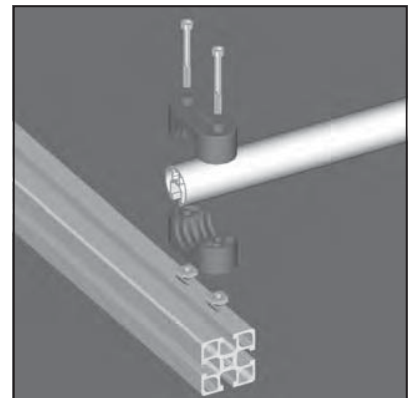
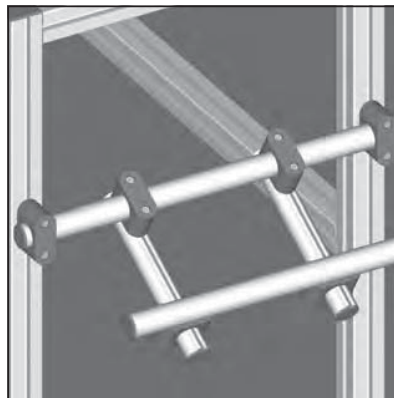
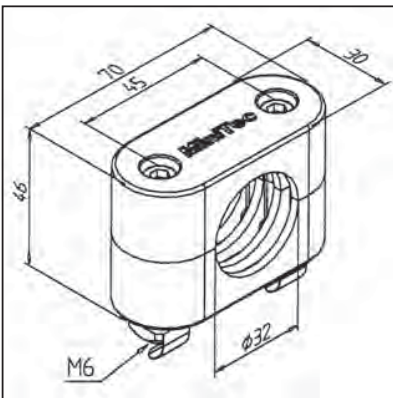

TECHN. DATA / ITEMS SUPPLIED

- Material: ABS, grey RAL 7012
- Fastening kit
- Weight 0,02 kg

APPLICATIONS

- For handle profile 32
- Handle with adjustable angle
- Simple equipment and frames

ASSEMBLY

- swivel in slide nuts
- Insert handle profile into the 2 half-shells
- Fasten with bolts

CATCH 32 FOR HANDLE PROFILE

part no. 21.0005/0

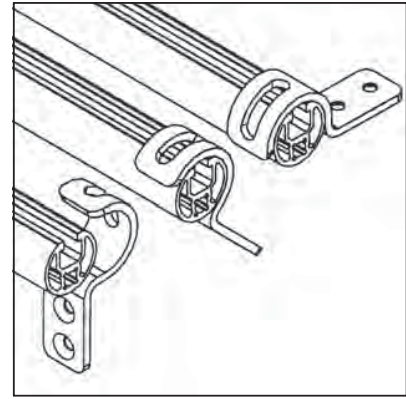
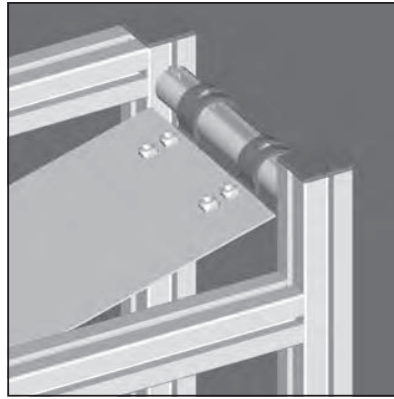
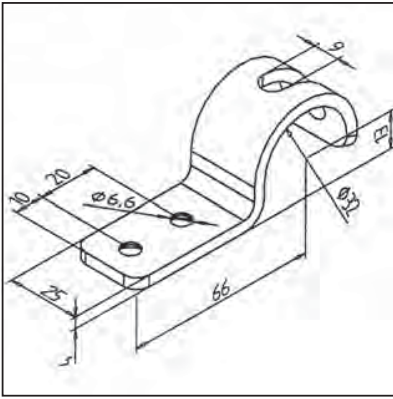
**TECHN. DATA / ITEMS SUPPLIED**

- Steel, powder coated grey
- Set screw M6x16
- Square nut M6
- Weight 0,08 kg

APPLICATIONS

- For flexible installation of handle profile 32 for roller strip

ASSEMBLY

- To connect use countersunk screw M6
- Hook into handle profile 32
- If required, use set screw M8 x 20 and square nut M8 to secure against sliding

EDGE PROTECTION

part no. 32.0572/0

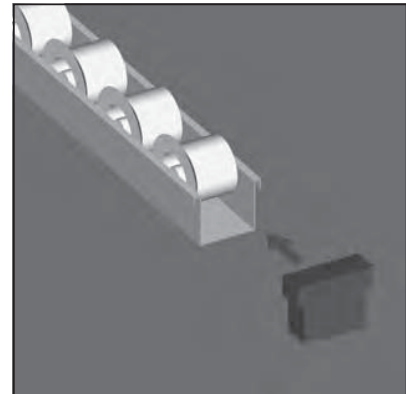
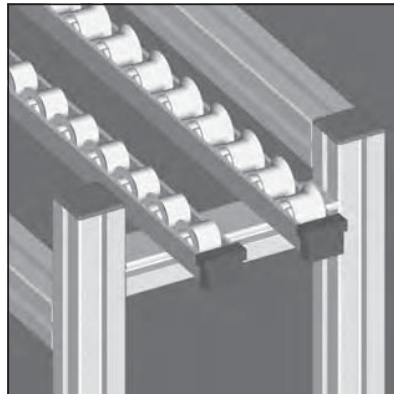
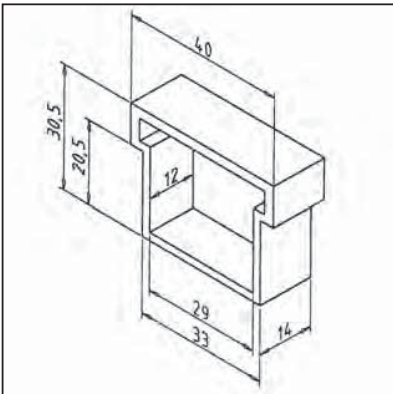
**TECHN. DATA / ITEMS SUPPLIED**

- Plastic, black
- ESD-capable
- Weight 0,004 kg

APPLICATIONS

- Protection against injury

ASSEMBLY

- slip on roller strip

BRAKE PLATE

part no. 32.0571/0

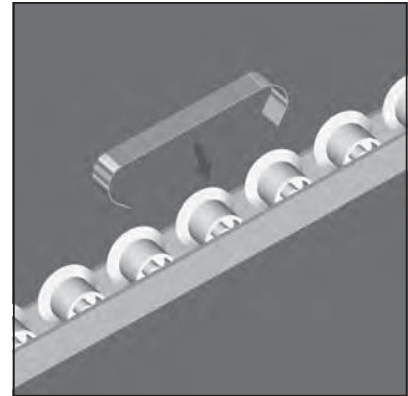
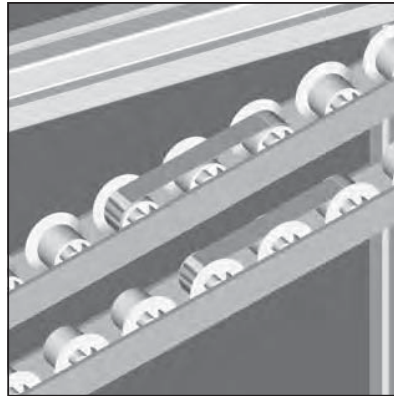
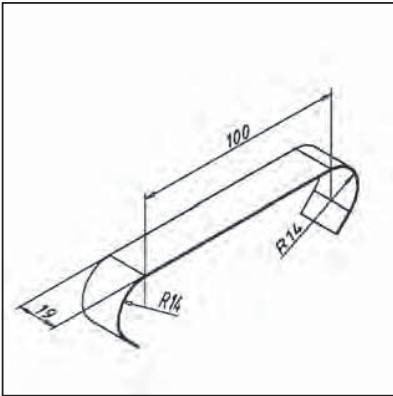

TECHN. DATA / ITEMS SUPPLIED

- Brake plate on spring steel for 50 mm division

- ESD capable combined with conductive rollers

- Weight 0,017 kg

APPLICATIONS

- The brake plate can be fastened at any desired location

ASSEMBLY

- Slip on roller strip

BRAKE-ROLLER

part no. 32.0562/0

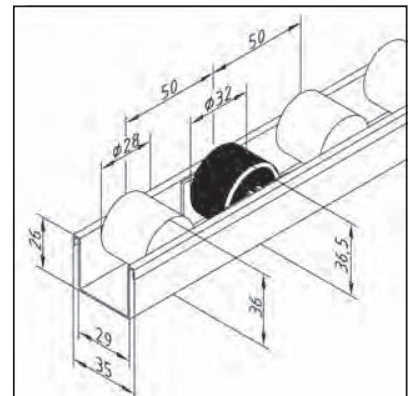
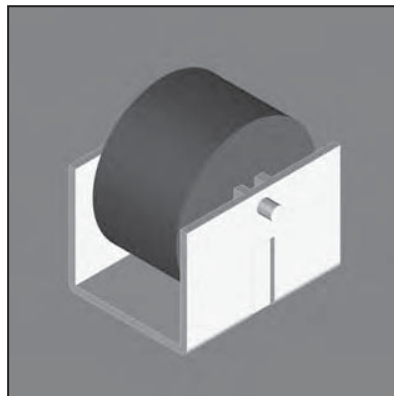
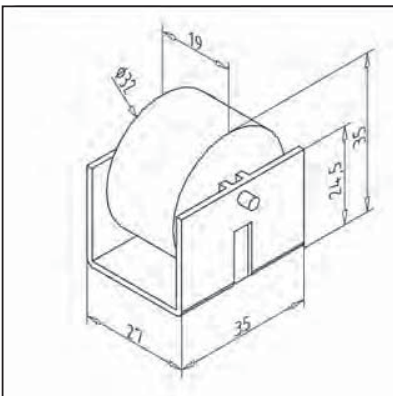

TECHN. DATA / ITEMS SUPPLIED

- Roller plastic, black

- support plastic black

- Weight 0,022 kg

APPLICATIONS

- used for roller strips with decline, to decelerate transported material

ASSEMBLY

- remove existing roller from roller strip

- insert support at the same place and clip brake-roller in

- pay attention to rolling direction of support and roller when mounting

BALL CASTER

part no. 35.0041/0

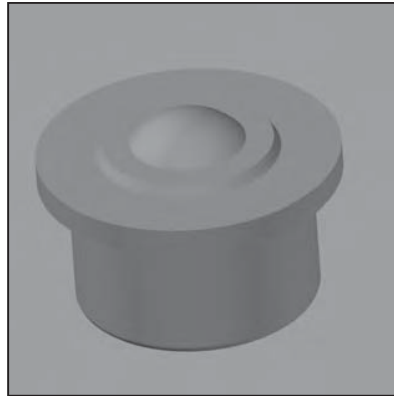
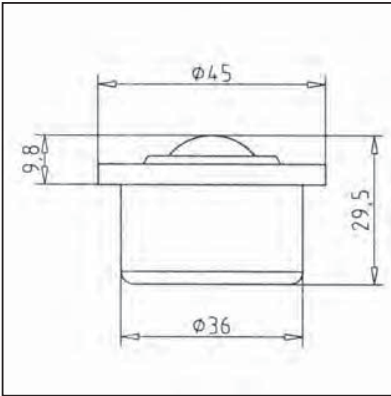
**TECHN. DATA / ITEMS SUPPLIED**

- Slide units made of steel sheet, galvanized, steel balls	
- DW	22,2 mm
- Basic load rating C:	1200 N
- Weight	0,13 kg

APPLICATIONS

- Ball casters for conveyors and automation systems
- Enable a simultaneous longitudinal and transverse movement
- Assembly into work tables or roller conveyors
- Ball casters also as running gear for crates, equipment, furniture and machines

ASSEMBLY

- Insert into prepared bore
- Or mount with tolerance ring **part no. 35.0001/0**
- Caution: for installation using tolerance ring of other bore diameter (37.7 + 0.2 mm)