



FIPA Vacuum generation



- > FIPA offers a broad range of vacuum generators – pneumatically operated or motor-driven
- > High suction power for short gripping time



Inline ejectors EIL

- > Easy installation directly in the tubing line close to the vacuum cup
- > Small and light
- > See page 388



Base ejectors with integrated blow-off

- > Installation directly on vacuum cups
- > Small and light
- > Ideally suited for robotic applications with very short cycles such as Delta Robots or similar
- > See page 390



Heavy-duty ejectors

- > Compensation of compressed air fluctuations between 3 and 6 bar
- > Additional inlet for blow-off for fast product release or vacuum switch connection for process monitoring (65.111, 65.130)
- > Rectangular design enables block assembly in centralized or decentralized vacuum systems
- > See page 392



Ejectors with air-saving function EMA

- > Electronic vacuum and blow-off control
- > Electronic air-saving function reduces operating costs up to 90 % with dense workpieces
- > Compact design, installation near to the vacuum cup
- > See page 394



FIPA Vacuum generation



Rotary vane vacuum pumps – oil-free

- > Handling of dense workpieces in dry areas
- > Suitable for load alternation and continuous operation
- > Available in single-phase and three-phase designs
- > Any installation position
- > Very low maintenance



Piston pumps

- > Small output at compact design
- > Suitable for dry and wet areas
- > Long-life and low maintenance thanks to the permanently lubricated piston seals
- > Oil-free operation
- > Also suitable as compressors



Rotary vane vacuum pumps – oil-lubricated

- > Handling dense and porous workpieces
- > Partially suitable for applications in wet areas
- > Suitable for continuous operation in product-dependent vacuum levels
- > Available in single-phase and three-phase designs
- > Horizontal installation position



Centralized vacuum units

- > Supply of several modules via a central station
- > Made up of one to three oil-lubricated vacuum pumps
- > Incl. vacuum tank and electronic control



On request

Side channel blowers – single-stage and double-stage

- > Handling of porous workpieces, such as cardboard boxes or untreated wooden pallets
- > Double-stage design offers higher suction power at the same vacuum level for effective leak compensation
- > Suitable for use in wet and dry areas
- > Suitable for continuous operation
- > Horizontal and vertical installation
- > Practically maintenance-free



Accessories

Vacuum tanks

- > Storage for compressed air, vacuum and non-aggressive liquids
- > Energy-saving assembly of compressed air and vacuum
- > For compressed air / vacuum networks with fluctuating demand

For additional product information please refer to the FIPA Vacuum Technology Catalog. Our technical customer service will be happy to help you find the optimal products for your application. (email: info@fipa.com; phone: +49 89 962489-0)



Inline ejectors EIL

Compressed air and vacuum connection via quick fittings, lateral exhaust



☐ = Vacuum connection ☐ = Compressed air connection ☐ = Exhaust outlet

Product notes

- > Easy installation directly in the tubing line close to the vacuum cup
- > High suction power enables short gripping times
- > Index H: ejectors for non-air-permeable products (max. vacuum degree 85 %)
- > Index L: ejectors for air-permeable products, resp. in case of higher leakage (increased suction, max. vacuum degree 60 %)

Technical data

Item no.	EIL.05H.1	EIL.05H.2	EIL.05L.1	EIL.05L.2	EIL.07H.1	EIL.07H.2	EIL.07L.1	EIL.07L.2
Nozzle diameter [mm]	0.5	0.5	0.5	0.5	0.7	0.7	0.7	0.7
Optimal operating pressure [bar (psi)]	5 (72.5)	5 (72.5)	5 (72.5)	5 (72.5)	5 (72.5)	5 (72.5)	5 (72.5)	5 (72.5)
Suction power at 5 bar (72.5 psi) [Nl/min]	8	8	14	14	13	13	28	28
Air consumption at 5 bar (72.5 psi) [Nl/min]	14	14	14	14	28	28	28	28
Final vacuum at 5 bar (72.5 psi) [%]	85	85	60	60	85	85	60	60
Evacuation time 0 to 70 % [s/l]	13	13	--	--	7.5	7.5	--	--
Evacuation time 0 to 45 % [s/l]	--	--	4	4	--	--	2	2
Weight [g]	13	15	13	15	13	15	13	15
Suitable plug-in filter	71.071 (p.364)	--	71.071 (p.364)	--	71.071 (p.364)	--	71.071 (p.364)	--

Dimensions

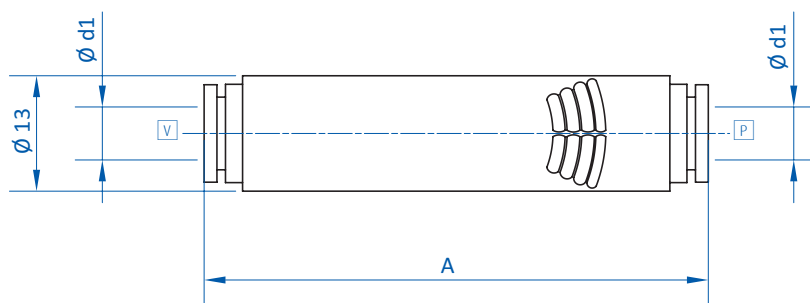

EIL.05H.1 | EIL.05L.1 | EIL.07H.1 | EIL.07L.1

☐ = Vacuum connection ☐ = Compressed air connection



Dimensions

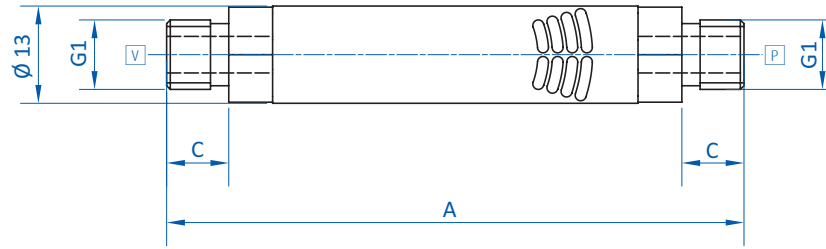

EIL.05H.2 | EIL.05L.2 | EIL.07H.2 | EIL.07L.2

V = Vacuum connection P = Compressed air connection

Item no.	EIL.05H.1	EIL.05H.2	EIL.05L.1	EIL.05L.2	EIL.07H.1	EIL.07H.2	EIL.07L.1	EIL.07L.2
G1	--	G1/8	--	G1/8	--	G1/8	--	G1/8
d1 [mm]	6	--	6	--	6	--	6	--
A [mm]	61	78	61	78	61	78	61	78
C [mm]	--	8	--	8	--	8	--	8

Diagrams

> Suction power and air consumption against feed pressure

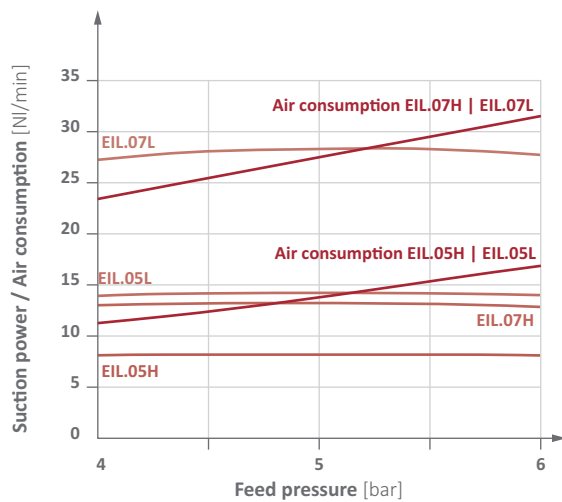

> Vacuum level against feed pressure

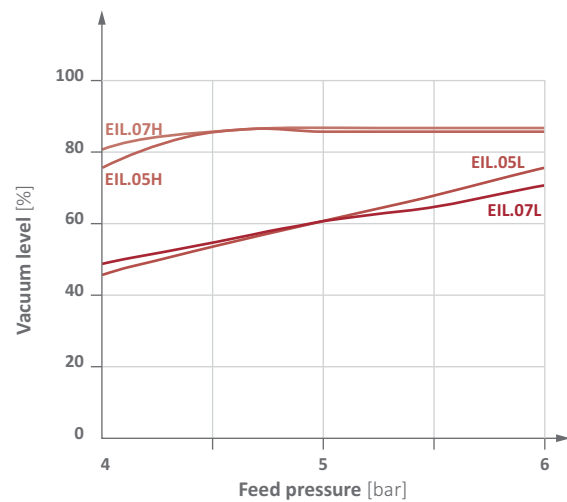

Suction power [Nl/min] at vacuum level

Item no.	0 %	10 %	20 %	30 %	40 %	50 %	60 %	70 %	80 %
EIL.05H.1	8	5.3	4.2	3.9	3.3	2.5	1.3	0.4	0.1
EIL.05H.2	8	5.3	4.8	3.9	3.3	2.5	1.3	0.4	0.1
EIL.05L.1	14	11.9	9	6.8	4.3	2.2	0.1	--	--
EIL.05L.2	14	11.9	9	6.8	4.3	2.2	0.1	--	--
EIL.07H.1	13	10.8	9.2	8.1	7	5.2	4.1	2.7	1.1
EIL.07H.2	13	10.8	9.2	8.1	7	5.2	4.1	2.7	1.1
EIL.07L.1	28	26	22.1	17.6	10.8	5.4	1.9	--	--
EIL.07L.2	28	26	22.1	17.6	10.8	5.4	1.9	--	--



Vacuum generation | Ejectors

Base ejectors with integrated blow-off

Base ejectors with integrated blow-off

VERY SHORT RESPONSE TIME, SAFE AND GENTLE PRODUCT RELEASE

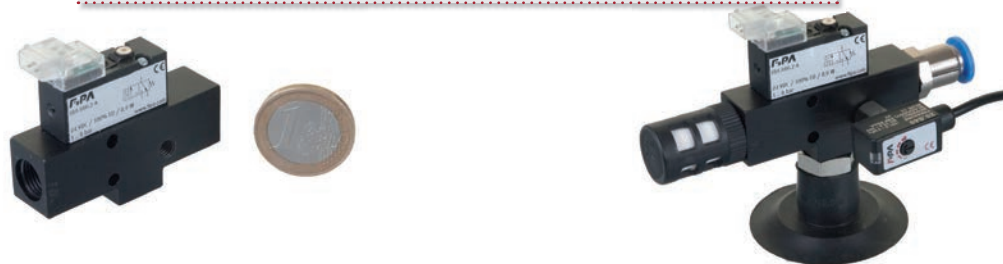

Example: ejector EBA.08H.2-A with digital mini vacuum switch 20.040, closed diffusor silencer 72.000 and flat vacuum cup \varnothing 40 mm

Product notes

- > Small and very light for installation directly on vacuum cups for fast vacuum build-up and short gripping times
- > Blow-off from a fast-reacting micro valve enables very short cycle times
- > Graded blow-off boost effect: initially the blow-off is supported by ambient air, for placement that is both quick and gentle
- > Robust design and long service life of > 100 million switching cycles
- > M5 connection for digital mini vacuum switch to ensure reliable process monitoring
- > Ideally suited for robotic applications with very short cycles such as Delta Robots (e.g. FlexPickers)

Ordering notes

- > Included in delivery: control cable 20.550, length 1.5 m, 2-wire, free end

Technical data

Item no.	EBA.08H.2-A
Nozzle diameter [mm]	0.8
Optimal operating pressure [bar (psi)]	5 (72.5)
Max. operating pressure [bar (psi)]	8 (116)
Final vacuum [%]	85
Suction power at 5 bar (72.5 psi) [NI/min]	25
Air consumption at 5 bar (72.5 psi) [NI/min]	30
Flow rate solenoid valve [NI/min]	15
Blow-off volumes of flow [NI/min]	110 - 45
Power-on time solenoid valve (ED) [%]	100
Power-on/-off time solenoid valve [ms]	5
Power consumption solenoid valve [W]	0.9
Control voltage	24 VDC \pm 10 %
Protection class	IP40
Operating temperature [$^{\circ}$ C ($^{\circ}$ F)]	-10 - 50 (14 - 122)
Weight [g]	35
Accessories	Connector cable: 20.550 (p.410), Vacuum switch: 20.040 (p.377), Vacuum switch: 20.041 (p.377), Silencer: 72.000 (p.399), Silencer: 72.028 (p.398)

Control cable 20.550



Cable assignment: red (+), black (-)



Integrated blow-off with boost-effect

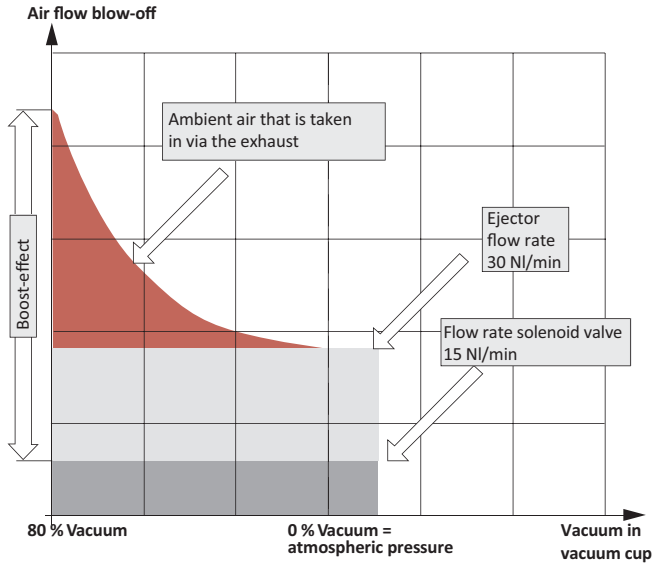

Evacuation / Blow-off time

Evacuation / Blow-off time 1 liter volume up to % vacuum / atmospheric pressure [sec.]		
0 → 50 % / 50 % → 0	0 → 60 % / 60 % → 0	0 → 70 % / 70 % → 0
1.8 / 0.5	2.5 / 0.56	3.9 / 0.61

Evacuation / Blow-off time: example with Ø 30 mm flat suction cups, volume 1.7 cm ³ up to % vacuum / atmospheric pressure [ms]		
0 → 50 % / 50 % → 0	0 → 60 % / 60 % → 0	0 → 70 % / 70 % → 0
3 / <1	4 / <1	7 / 1

Dimensions

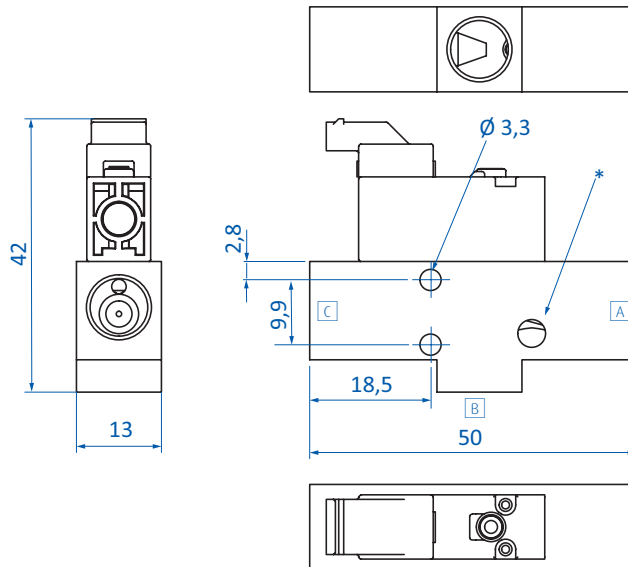

A = Compressed air connection G1/8-female
 B = Vacuum connection G1/8-female
 C = Exhaust outlet G1/8-female
 * = M5 connection for vacuum switches



Heavy-duty ejectors

Vacuum generation for use under harsh operating conditions



Product notes

- > Robust and compact aluminum housing
- > Compensation of compressed air fluctuations between 3 and 6 bar (43.5 and 87 psi)
- > Additional inlet for blow-off for fast product release or vacuum switch connection for process monitoring (65.111, 65.130)
- > Rectangular design enables block assembly in centralized or decentralized vacuum systems

Technical data

Item no.	Optimal operating pressure [bar (psi)]	Max. operating pressure [bar (psi)]	Final vacuum [%]	Suction power [Nl/min]	Air consumption to 4 bar (58 psi) [Nl/min]	Evacuation time 0 to 70% [s/l]	Weight [g]	Accessories
65.102A	4 (58)	6 (87)	85	30	50	3.5	48	Silencer: 72.001 (p.399) Silencer: 72.029 (p.398)
65.111	4 (58)	6 (87)	85	33	60	3	120	Silencer: 72.002 (p.399) Silencer: 72.030 (p.398)
65.120	4 (58)	6 (87)	85	85	130	1.5	125	Silencer: 72.031 (p.398)
65.130	4 (58)	6 (87)	85	130	240	0.7	225	Silencer: 72.033 (p.398)

Dimensions

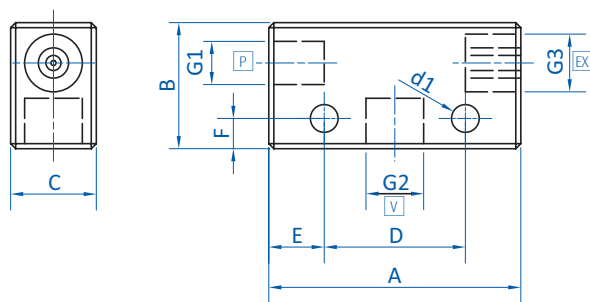

65.102A

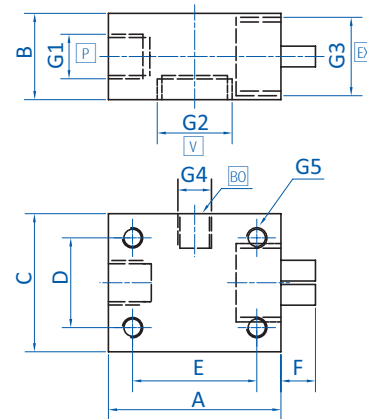

65.111 | 65.120 | 65.130

P = Compressed air connection V = Vacuum connection Ex = Exhaust BO = Blow-off (65.111 and 65.130)

Item no.	G1	G2	G3	G4	G5	A [mm]	B [mm]	C [mm]	D [mm]	d1 [mm]	E [mm]	F [mm]
65.102A	G1/8	G1/4	G1/4	--	--	50	25	17	28	5.5	11	6
65.111	G1/4	G1/2	G3/8	G1/8	6.5	50	25	40	25	--	34	8
65.120	G1/4	G1/2	G1/2	G1/8	M6	50	25	40	25	--	34	10
65.130	G1/4	G1/2	G1	G1/8	M6	60	40	40	25	--	34	--



Diagrams

> Suction power against feed pressure

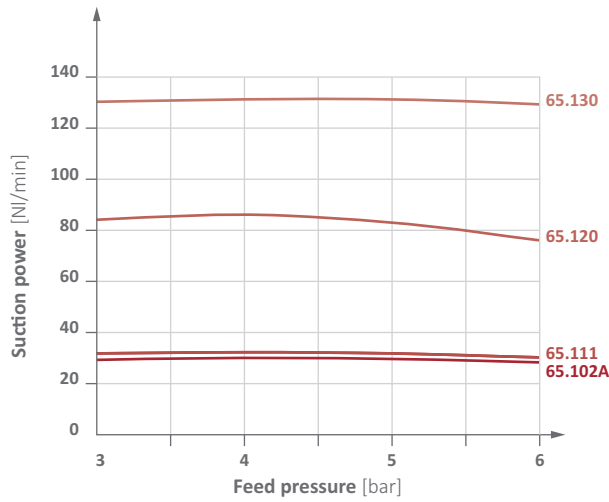

> Air consumption against feed pressure

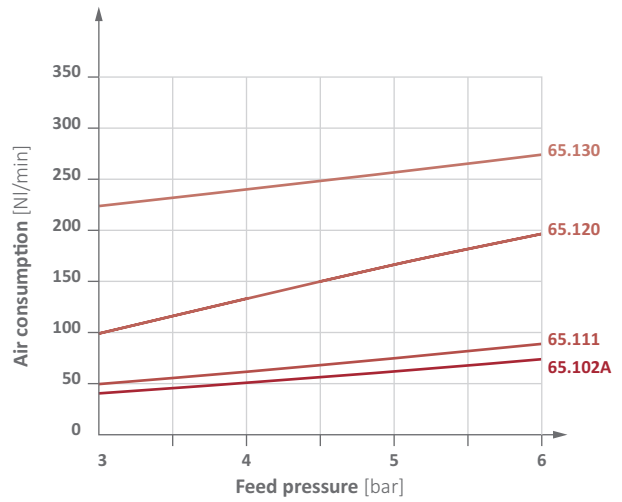

> Vacuum level against feed pressure

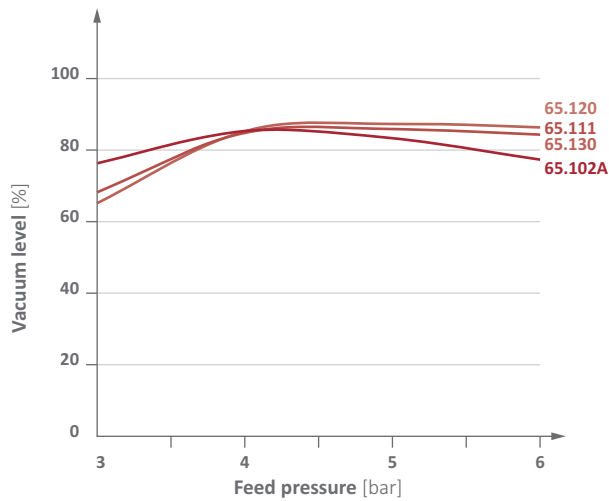

Suction power [Nl/min] at vacuum level

Item no.	10 %	20 %	30 %	40 %	50 %	60 %	70 %	80 %
65.102A	25	23	19	15	13	8	4	1
65.111	25	23	20	17	13	8	4	1
65.120	76	66	55	41	34	22	12	3
65.130	182	160	135	69	52	33	17	6



Vacuum generation | Ejectors

Ejectors with air-saving function EMA

Ejectors with air-saving function EMA

Double energy efficient by integrated pressure control and electronic air-saving function



SAVES UP TO 90 % OF ENERGY

Product notes

- > Electronic air-saving function reduces operating costs by up to 90 % with dense workpieces
- > Pressure regulation energy-saving function at constant 3.5 bar (50.76 psi) reduces operating costs by up to 50 % with porous workpieces
 - Energy saving increases along with the difference between supply pressure and operating pressure
- > Electronic vacuum and blow-off control for short cycle times
- > Manual adjustment of the blow-off flow rate using a setscrew
- > Very compact design with integrated open silencer
- > Dust-resistant design, no additional filters required
- > NO-version on request
- > Smaller nozzle diameters on request
- > If the ejector experiences power failure, the workpiece is only held by the vacuum between non-return valve and product surface
- > Vacuum and blow-off are controlled using a single signal

Technical data

Item no.	EMA.90x14
Nozzle diameter [mm]	1.4
Feed pressure [bar (psi)]	4 - 8 (58 - 116)
Internal working pressure [bar (psi)]	3.5 (50.8)
Final vacuum [%]	90
Suction power [NI/min]	70
Air consumption [NI/min]	90
Protection class	IP65
Operating principle	NC
Control voltage	24 VDC (adjusted) ± 10 %
Current consumption for vacuum and blow-off feature [mA]	30 (0.7 W)
Noise level [dB(A)]	68
Operating temperature [°C (°F)]	10 - 60 (50 - 140)
Weight [g]	130
Suitable connector cable	20.501 (p.410) 20.502 (p.410)



Pneumatic diagram

Solenoid valve NC

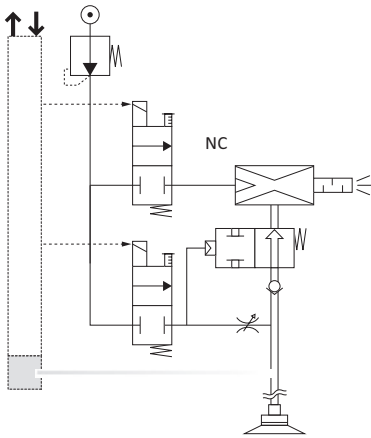

Solenoid valve NO

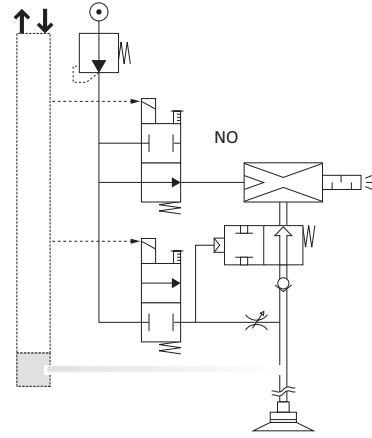

Operating principle EMA series

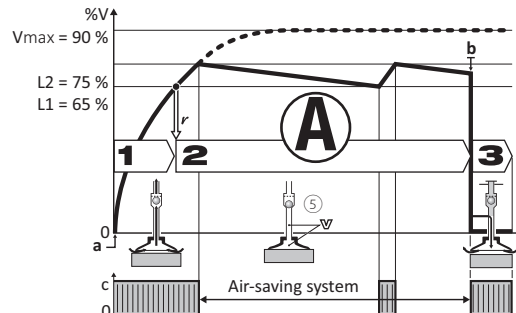
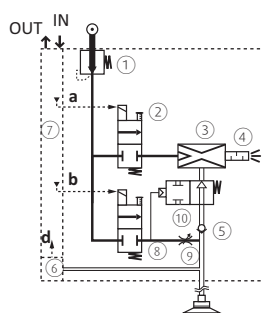
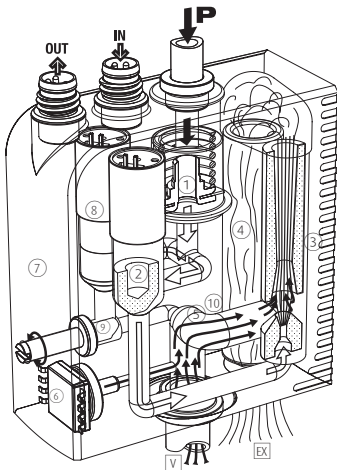

1. Gripping the workpiece

The vacuum solenoid valve (2) starts the cycle. Venturi nozzle (3) is supplied with compressed air and generates the vacuum to grip the item quickly with the vacuum cup → short-term energy consumption.

2. Operations on the suctioned item

The vacuum level is continually monitored by the vacuum switch (6). When the vacuum threshold limit L1 (65 %) is reached the signal "Item gripped" is triggered. This gives a green light for the scheduled operation (transfer, processing, etc.). When the vacuum reaches the threshold limit L2 (75 %), the compressed air supply to the venturi nozzles via the solenoid valve (5) is interrupted. Energy consumption falls to zero. The item remains gripped because of the vacuum that remains because of the closed non-return valve. Tiny leakages often lead to a slow release of the vacuum. If the vacuum falls to the threshold limit of 65 %, new vacuum is briefly generated, i.e. until the threshold limit L2 (75 %) is reached.

3. Releasing the workpiece

At the end of the procedures blow-off is triggered. The blow-off valve (8) generates an air jet that closes the closing valve (10). This blows off the item using the air pressure regulator (9) so that it can be released more quickly.

Continued on the next page →



Nozzle diameter and energy-saving potential

Air-saving control cycle self-adaptation

Cycle 1:
Deals with an airtight product under the influence of LSA, resulting in optimum energy savings

Cycle 2:
The porous product generates leaks that provoke repeated intermittent vacuum regeneration. The anomaly is automatically detected and the cycle goes on without LSA. An LSA missing signal is emitted and displayed, and production goes on.

Cycle 3:
Illustrates the automatic return to the LSA cycle as soon as leaks are eliminated due to airtight products. Vacuum level will be maintained.

The compact-ejector EMA thus provides maximum energy saving, without any limitations to the performance and functioning of the overall production system.

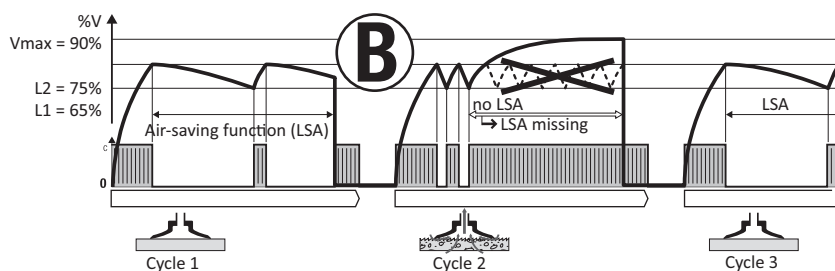

Without automatic air-saving system			With automatic air-saving system		
Nozzle diameter [mm]	Suction power [NI/min]	Air consumption [NI/min]	Suction duration (65 % vacuum) [sec]	Suction duration (75 % vacuum) [sec]	Air consumption [NI/min]
1	29	44	2.38	3.33	2.2
1.2	45	65	1.53	2.15	2.2
1.4	70	90	0.99	1.38	2.2

> Automatic air-saving system activation allows a larger tube diameter to grip more quickly without increased consumption.

Example of the air-saving potential

The examples show how the automatic air-saving function reduces the energy demand:

> 75 % energy saved during product transfer

> 97 % energy saved during holding products while they are further processed or treated

The investment will often amortise itself within a couple of months.

Gripping + transfer (nozzle \varnothing 1.4 mm, evacuation of 0.2 l)

Phase	Duration	Air consumption		air-saving potential
		without "LSA"	with "LSA"	
Grip	0.28 s	0.4 NI	0.4 NI	75 %
Transfer	1.20 s	1.8 NI	0	
Placement	0.14 s	0.2 NI	0.2 NI	
		2.4 NI	0.6 NI	

Fixation + operation process (nozzle \varnothing 1.4 mm, evacuation of 0.4 l)

Phase	Duration	Air consumption		air-saving potential
		without "LSA"	with "LSA"	
Fixation	0.55 s	0.8 NI	0.8 NI	97 %
Operation process	60 s	90 NI	0	
Placement	0.14 s	0.2 NI	0.2 NI	
		91 NI	1.0 NI	



Wiring diagram

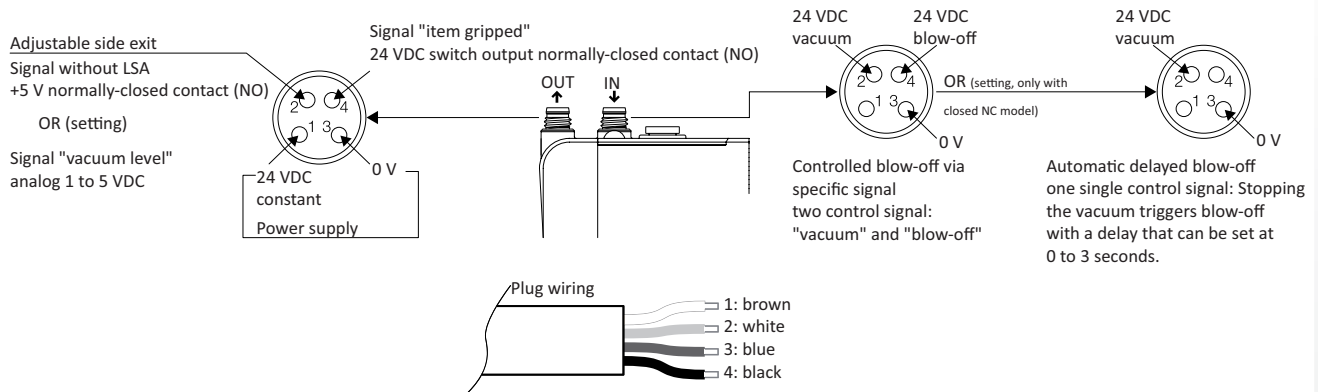

- > Output signal "object gripped", 24 VDC, switching output NO, switching current 125 mA, PNP
- > Adjustable side output:
 1. Signal without air-saving function, +5 V switching output NO: e.g. signal for failure indication
 2. Signal "vacuum level", analog, 1-5 VDC of measuring range

Dimensions and mounting options

> Mounting sideways

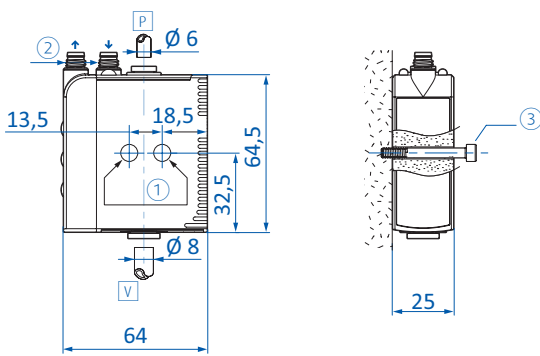

> Mounting in the front

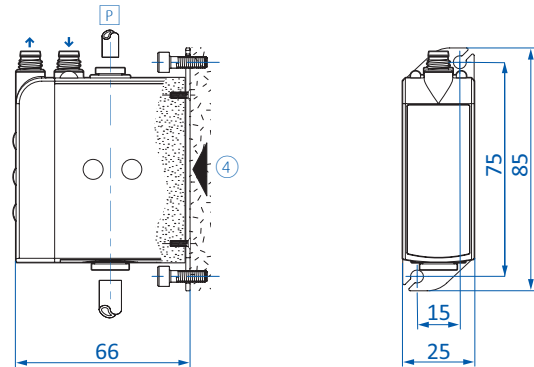

> Block mounting on a DIN rail

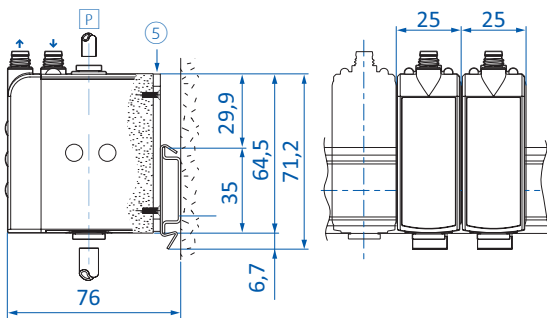

> EMA.FIX-B endpieces, with connecting screws and closing pins for collecting main

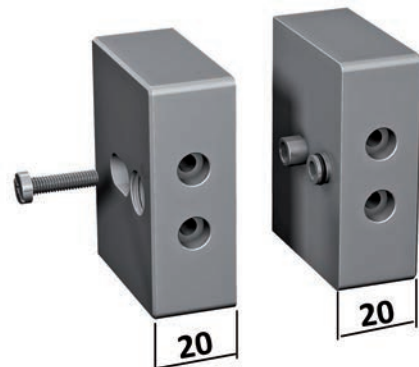

P = Compressed air connection V = Vacuum connection ① = 2 Bore holes for 4 mm screws ② = M8 plug ③ = 2 Continuous screws ④ = Mounting plate with 4 screws (Item no. EMM.FIX-V) ⑤ = Mounting plate for DIN rail with 4 screws (Item no. EMM.FIX-D) – on plate per EMM module

Evacuation time [sec.] for 1 liter at vacuum level

Item no.	55 %	60 %	65 %	70 %	75 %	80 %
EMA.90x14	0.73	0.85	0.99	1.16	1.38	1.7



Open silencers for ejectors



Product notes

- > Suitable for heavy-duty ejectors
- > Open design, specially suitable for dusty, high-particle environments (e.g. wood industry)

Technical data		Dimensions				
Item no.	Weight [g]	G	Ø D [mm]	Ø Di [mm]	L [mm]	L1 [mm]
72.028	3	G1/8	14	7	46	41
72.029	20	G1/4	20	11	73	65
72.030	25	G3/8	24	11	72	64
72.031	35	G1/2	30	17	128	121
72.032	55	G3/4	40	17	126	119
72.033	175	G1	49	26	126	119

Dimensions

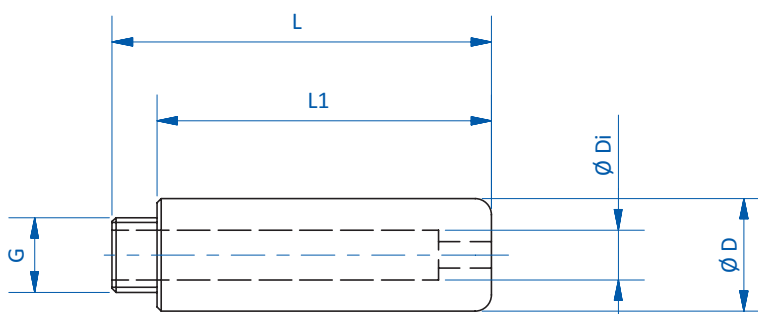



Closed silencers for ejectors



Product notes

- > Closed diffuser/silencer specially designed for dust-free environments
- > Suitable for heavy-duty ejectors

Technical data

Item no.	Weight [g]
72.045	5
72.000	2
72.001	3.5
72.002	12
72.003	15
72.007	5.5
72.008	3
72.009	6.5

Dimensions

G1	$\varnothing D$ [mm]	A [mm]	$\varnothing B$ [mm]	C [mm]	$\varnothing P$ [mm]
G1/8	--	41	18	6	--
G1/8	--	28	15.5	6	15.5
G1/4	--	38	17.5	8	17.5
G3/8	--	58	26	10	26.5
G1/2	--	66	29	12	29
--	4	30	--	11	10.5
--	6	34.5	--	11.5	15.5
--	8	48.5	--	17.5	17.5

Dimensions

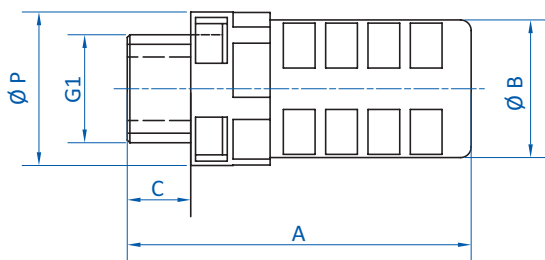

72.045 | 72.000 | 72.001 | 72.002 | 72.003

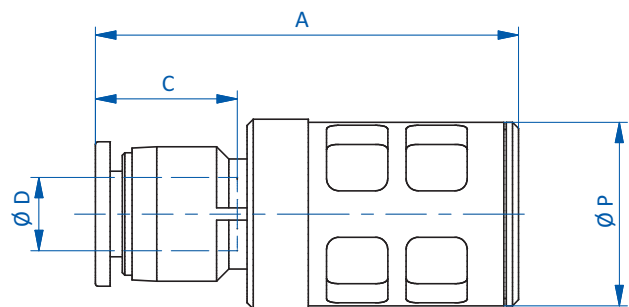

72.007 | 72.008 | 72.009



Silencers with filter function



Series 1: brass construction with stainless steel wire fabric



Series 2: brass construction with sintered material

Product notes

- > Combination of silencer and air filter
- > 72.015 - 72.021: also suitable as protective filter for 3/2-way valves at ventilation/blow-off inlet (under contaminated environmental conditions)
- > 72.022 - 72.027: can be mounted directly into the vacuum cup or the fitting, temperature-resistant up to 120 °C (248 °F)

Technical data

Item no.	Series	Weight [g]
72.015	1	2
72.016	1	6
72.017	1	10
72.018	1	15
72.019	1	25
72.020	1	38
72.021	1	56
72.022	2	1
72.023	2	3
72.024	2	6
72.025	2	12

Dimensions

G	B [mm]	Ø D [mm]	L [mm]	L1 [mm]	SW
M5	3.5	2.5	9.5	4	8
G1/8	4	6	14	6	13
G1/4	5	8.5	18.5	8	16
G3/8	6	11	19.5	8	19
G1/2	5	15	22.5	10	24
G3/4	6	20	25.5	10	30
G1	6.5	26	31	11.5	36
G1/8	--	5.5	4.5	3.5	--
G1/4	--	7	6.8	4.5	--
G3/8	--	9.5	6.8	5	--
G1/2	--	12	9	7	--

Dimensions

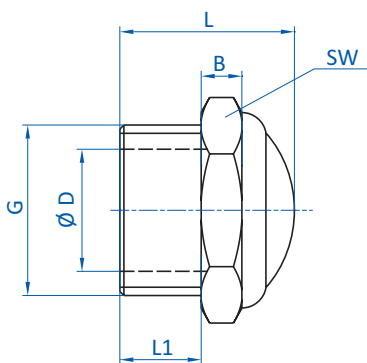

72.015 | 72.016 | 72.017 | 72.018 | 72.019 | 72.020 | 72.021

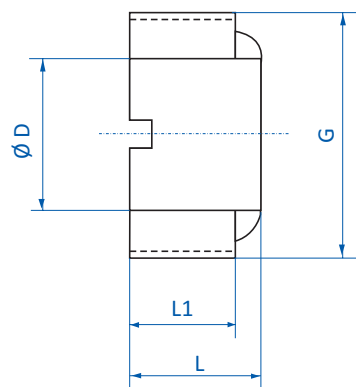

72.022 | 72.023 | 72.024 | 72.025